

Marine Catalogue



www.vdo.net.au

Viewline—the new generation in instrumentation

- ◆ **Sumlog**
- ◆ **Tachometer & Tachourmeter**
- ◆ **Gauges for engine monitoring**
- ◆ **Basic navigation instruments**

VDO



Page #



VDO - Wempe Clocks 4



Underwater Lights 5



Viewline Instruments 16



Oceanlink Instruments 33





Sensors 34



Clocks & Weather Station



With over 100 Years of experience in products dedicated to the marine world, VDO stands for quality . The new series of Black Ocean and White Ocean is a union of refined elegance.

Dial Colour	Part number	Description
 Black	CW700011	Clock VDO Black Ocean Ø 100mm desk or wall mount , polished Stainless-Steel case with grey pointers
	CW700012	Barometer VDO Black Ocean Ø 100mm desk or wall mount , polished Stainless-Steel case with grey pointers
	CW700013	Hygrometer/Thermometer VDO Black Ocean Ø 100mm desk or wall mount , polished Stainless-Steel case with grey pointers
 White	CW700014	Clock VDO White Dial Ocean Ø 100mm desk or wall mount, Satin Stainless-Steel case with black pointers
	CW700015	Barometer VDO White Dial Ocean Ø 100mm desk or wall mount, Satin Stainless-Steel case with black pointers
	CW700016	Hygrometer/Thermometer VDO White Ocean Ø 100mm desk or wall mount , Satin Stainless-Steel case with black pointers

Underwater Lights

VDO transferred its technology developed in decades of leadership from Automotive market to Nautical Market, producing a range of through-hull lights made by Power LED technology, which offers a power light as best as are also the best xenon light but with considerably lower power consumption with 12-28V power supply and a endless lifetime.



Part number	Angle	Colour	Diameter
ITA-039-UWL-619	60°	White	80mm
ITA-039-UWL-519	90°	White	80mm
ITA-039-UWL-629	60°	White	100mm
ITA-039-UWL-529	90°	White	100mm
ITA-039-UWL-639	60°	White	120mm
ITA-039-UWL-539	90°	White	120mm
ITA-039-UWL-649	60°	White	150mm
ITA-039-UWL-549	90°	White	150mm



Four different length available: 80, 100, 120, 150 mm



Submersible Lights

Specs

:

- Full Steel INOX AISI316 body
- High lux POWER LED lamps with internal controller
- Low power consumption
- 50.000 hours LED lifetime
- 2 available beams (60° and 90°)
- Narrow beam (12°) on request
- White illumination (4000°K)
- Low Maintenance
- Easy Installation
- Free Voltage (between 12 and 28Vdc)
- Access to LED from the hull
- Operation at low temperature (-10°)
- Fully IP68 (front and back protection)
- 6mm tempered glass mounted on 3 o-ring
- Hermetic seal till 0.65bar
- Sealed RCA connector gold plated
- 5m rubber flexible cable
- ABS certification (American Bureau of Shipping)

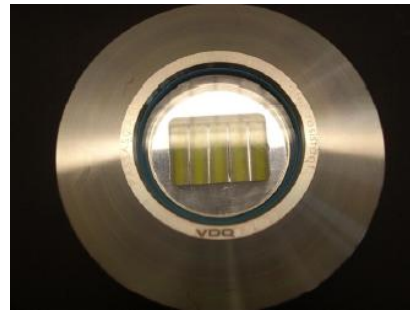
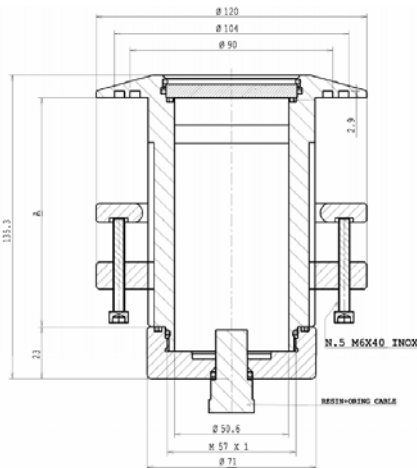

5 LED Light assembly



6 LED Light assembly



Back LED Light view

Illuminator type	6 LED 3W	5 LED 6W
Supply Voltage	12 - 28V (DC)	12 - 28V (DC)
POWER LED	6 x 3W LED high lux 660lm effic.72W	5 x 6W LED high lux 1500lm effic.120W
Colour temperature	White 4.000°K	White 5.000°K
Beam Angle	60°	90°
Lifetime	50.000 hours	50.000 hours
Min. operating temp	10°C	10°C

Viewline Gauges Index

Description	Notes	Diameter	Page #
Conversion Table	Oceanline to Viewline Gauges		8 - 9
Sumlog	Speedometer 50Kn	80/85mm	16
Tachourmeter	Tachourmeter 3000, 4000, 5000, 6000 RPM	80/85mm	16 - 17
Tachometer	Tachometer 3000, 4000, 6000 RPM	80/85/52mm	17 - 18
Synchroniser	+ / - 500 RPM	80/85mm	18
Temp Gauge	Water, Oil, Transmission	52mm	19
Pyrometer	Exhaust Temp 100°C to 900°C	52mm	20
Temp Gauge Outside	Air Temp -25° to +50°C	52mm	21
Pressure Gauge	Turbo, Oil, Transmission	52mm	21 - 23
Fuel Level Gauge	Float Arm Type	52mm	24
Fuel Level Gauge	Reed Switch Type	52mm	25
Fuel Level Gauge	Tubular Type	52mm	25 - 28
Fuel Level Gauge	US Lever Type 240 - 33 Ohms	52mm	28
Fresh Water Level Gauge	Reed Switch Type	52mm	29
Waste/Grey Water Gauge	4-20 mA	52mm	30
Hourmeter	Engine Hours	52mm	30
Voltmeter	Battery Voltage	52mm	31
Ammeter	Ampere Meter 60 A and +150 A	52mm	31
Trim Gauge	Outboard Engine Trim	52mm	32
Rudder Angle Gauge	Rudder Position	52/80/85mm	32
Clock	Real Time Clock	52mm	32
Oceanlink	J1939 & Analogue Master and Slaves	85/52mm	33
Sensors	Various sensors		34 - 44
Electrical Diagrams	Gauges connection (power and signals)		45 - 61
Gauges Accessories	Bezels - Plugs & Terminals - Tools		62 - 64
Fitting Instructions	Conventional & flush mount fittings		65 - 69
Calibration Instructions	Speedo, Tachourmeter & Tachometer		70 - 77

Conversion Table



Oceanline to Viewline Gauges

Previous Oceanline Part number	New Viewline Part number	Gauge dial and Bezel Colour	Main Function	Voltage	Ø	Range
N01113014	A2C59512405	BLACK	Sumlog LCD (Speedo)	12/24V	85	50kn
N01211022	A2C59512564	BLACK	Trim	12V *	52	Down
N02011116	A2C59512344	BLACK	Tacho	12/24V	52	4000rpm
N02011118	A2C59512345	BLACK	Tacho	12/24V	52	6000rpm
N02012106	A2C59512396	WHITE	Tachourmeter	12/24V	85	3000rpm
N02012110	A2C59512397	WHITE	Tachourmeter	12/24V	85	4000rpm
N02012114	A2C59512398	WHITE	Tachourmeter	12/24V	85	5000rpm
N02012122	A2C59512399	WHITE	Tachourmeter	12/24V	85	6000rpm
N02012146	A2C59512390	BLACK	Tachourmeter	12/24V	85	3000rpm
N02012150	A2C59512391	BLACK	Tachourmeter	12/24V	85	4000rpm
N02012154	A2C59512392	BLACK	Tachourmeter	12/24V	85	5000rpm
N02012162	A2C59512393	BLACK	Tachourmeter	12/24V	85	6000rpm
N02012406 & N02012706	A2C59512433	WHITE	Tacho	12/24V	85	3000rpm
N02012410 & N02012710	A2C59512434	WHITE	Tacho	12/24V	85	4000rpm
N02012414 & N02012714	A2C59512435	WHITE	Tacho	12/24V	85	6000rpm
N02012426 & N02012726	A2C59512430	BLACK	Tacho	12/24V	85	3000rpm
N02012430 & N02012730	A2C59512431	BLACK	Tacho	12/24V	85	4000rpm
N02012434 & N02012734	A2C59512432	BLACK	Tacho	12/24V	85	6000rpm
N02124102 & N02124502	A2C59512617	WHITE	Press Turbo	12V *	52	2bar
N02124106 & N02124506	A2C59512618	WHITE	Press Oil	12V *	52	5bar
N02124110 & N02124510	A2C59512619	WHITE	Press Oil	12V *	52	10bar
N02124114 & N02124514	A2C59512620	WHITE	Press Oil	12V *	52	25bar
N02124118 & N02124518	A2C59512621	WHITE	Press Oil	12V *	52	30bar
N02124122 & N02124522	A2C59512599	BLACK	Press	12V *	52	2bar
N02124126 & N02124526	A2C59512601	BLACK	Press Oil	12V *	52	5bar
N02124130 & N02124530	A2C59512603	BLACK	Press Oil	12V *	52	10bar
N02124134 & N02124534	A2C59512605	BLACK	Press Trans	12V *	52	25bar
N02124138 & N02124538	A2C59512607	BLACK	Press Trans	12V *	52	30bar
N02222102 & N02222302	A2C59512508	WHITE	Level Fuel	12V *	52	1/1
N02222112 & N02222312	A2C59512497	BLACK	Level Fuel	12V *	52	1/1
N02222502 & N02222702	A2C59512509	WHITE	Level Fuel	12V *	52	1/1
N02222512 & N02222712	A2C59512499	BLACK	Level Fuel	12V *	52	1/1

* Temporary measure: For 24V application, use Voltage Dropping Resistor P/n A2C59510221 without connector or P/n A2C59510853 with 8 pins connector

Conversion Table



Oceanline to Viewline Gauges

Previous Oceanline Part number	New Viewline Part number	Gauge colour dial/bezel	Main Function	Voltage	Ø	Range	Scale	FSD
N02230602	A2C59512341	WHITE	Level Freshwater	12/24V	52	1/1		20mA
N02230612	A2C59512340	BLACK	Level Freshwater	12/24V	52	1/1		20mA
N02230622	A2C59512343	WHITE	Level Waste water	12/24V	52	1/1		20mA
N02230626	A2C59512342	BLACK	Level	12/24V	52	1/1		20mA
N02230702	A2C59512559	WHITE	Level Freshwater	12V *	52	F	S	LT-EU
N02230712 & N02230812	A2C59512514	BLACK	Level Freshwater	12V *	52	1/1	S	LT-EU
N02340702	A2C59512333	WHITE	Pyrometer	12/24V	52	900°C		37mV
N02340712	A2C59512332	BLACK	Pyrometer	12/24V	52	900°C		37mV
N02340714	A2C59512334	BLACK	Pyrometer	12/24V	52	1650°F		37mV
N02321402	A2C59512336	BLACK	Temp Outside	12/24V	52	+50°C		2kOhm
N02321502	A2C59512338	WHITE	Temp Outside	12/24V	52	+50°C		2kOhm
N02321602 & N02321702	A2C59512555	WHITE	Temp Water	12V *	52	120°C	D	EU
N02321606	A2C59512556	WHITE	Temp Oil	12V	52	150°C	D	EU
N02321612 & N02321712	A2C59512548	BLACK	Temp water	12V *	52	120°C	D	EU
N02321616 & N02321716	A2C59512550	BLACK	Temp Oil	12V *	52	150°C	D	EU
N02400306	A2C59512330	WHITE	Amp ext. Shunt	12/24V	52	+60A		60mV
N02420712	A2C59512328	BLACK	Amp ext. Shunt	12/24V	52	+60A		60mV
N02420714	A2C59512329	BLACK	Amp ext. Shunt	12/24V	52	+150A		60mV
N02410802	A2C59512546	WHITE	Volt	12V *	52	16	S	
N02410812	A2C59512545	BLACK	Volt	12V *	52	1/1	S	
N02410902	A2C59512459	WHITE	Volt	24V	52	32V	S	
N02410912	A2C59512458	BLACK	Volt	24V	52	32V	S	
N03110404	A2C59512454	WHITE	Hourmeter	12/24V	52			
N03110412	A2C59512453	BLACK	Hourmeter	12/24V	52			
N03211402 & N03211502	A2C59512562	WHITE	Rudder angle	12V *	52	40°Stb	S	
N03211202	A2C59512411	WHITE	Rudder angle	12/24V	85	+45°	S	
N03211206	A2C59512410	BLACK	Rudder angle	12/24V	85	+45°	S	
N03211412 & N03211512	A2C59512561	BLACK	Rudder angle	12V *	52	40°Stb	S	
N03270602	A2C59513443	WHITE	Clock	12V *	52		S	
N03270603	A2C59513444	WHITE	Clock	24V	52		S	
N03270612	A2C59513445	BLACK	Clock	12V *	52		S	
N03270613	A2C59513446	BLACK	Clock	24V	52		S	

* Temporary measure: For 24V application, use Voltage Dropping Resistor P/n A2C59510221 without connector or P/n A2C59510853 with 8 pins connector



Introducing VDO Viewline

Our engineers started with a clean sheet of paper and a worldwide view to create an instrument line like no other in today's market.

Their goal to create an instrument with flexibility, class and integrity something you've come to expect from VDO.

It begins with a fresh style and three choices of instrument sizes 100mm, 85mm and 52mm.

For styling, you have a choice of dial face colors of Black or White.

Next we added three choices of bezel styles along with two choices of bezel colors, white, black and chrome.

To complete your choices we give you three choices of instrument sizes 100mm, 85mm and 52mm giving you more flexibility than ever to create the instrument you are looking for.

They did not stop with just a pretty face, next they added integrity.

With the use of fully sealed dual lens, lifetime LED lighting and warning indicators assure you that Viewline can withstand even open cab environments easily.

Whether you are looking for standard or customized products, you are truly getting "more bang for your buck" with Viewline.

The VDO Heritage: **Reliability, durability and accuracy.**

Reliability

- IP67 water resistance means, that no matter how wet it gets, our gauges keep on working.
- Anti-corrosion materials mean no oxidation or rust will develop – Viewline will continue to work and look like new.

Accuracy

- VDO patented stepper motors and resistive movements.
- OEM derived technology in every instrument.

Durability

- CE certification.
- GL registered.
- UL94 flame resistance.
- Tested to 25 G continuous vibration and 100 G shock.
- 100% LED warning lights and telltales for long service life.

Viewline Gauges

Viewline is the new standardised instrument platform for pleasure boats and yachts. With modular solutions in three housing variations, we supply more functions, more flexible installation and design options as well as space-saving combi instruments – something unique in this sector.

All Viewline instruments can be conveniently mounted in the instrument panel.

Here, it is possible to use the modular bezels for installation as well as integrating the instruments flat without the bezels (flush installation).

This allows maximum flexibility in cockpit customisation and numerous design variants.



Viewline Gauges

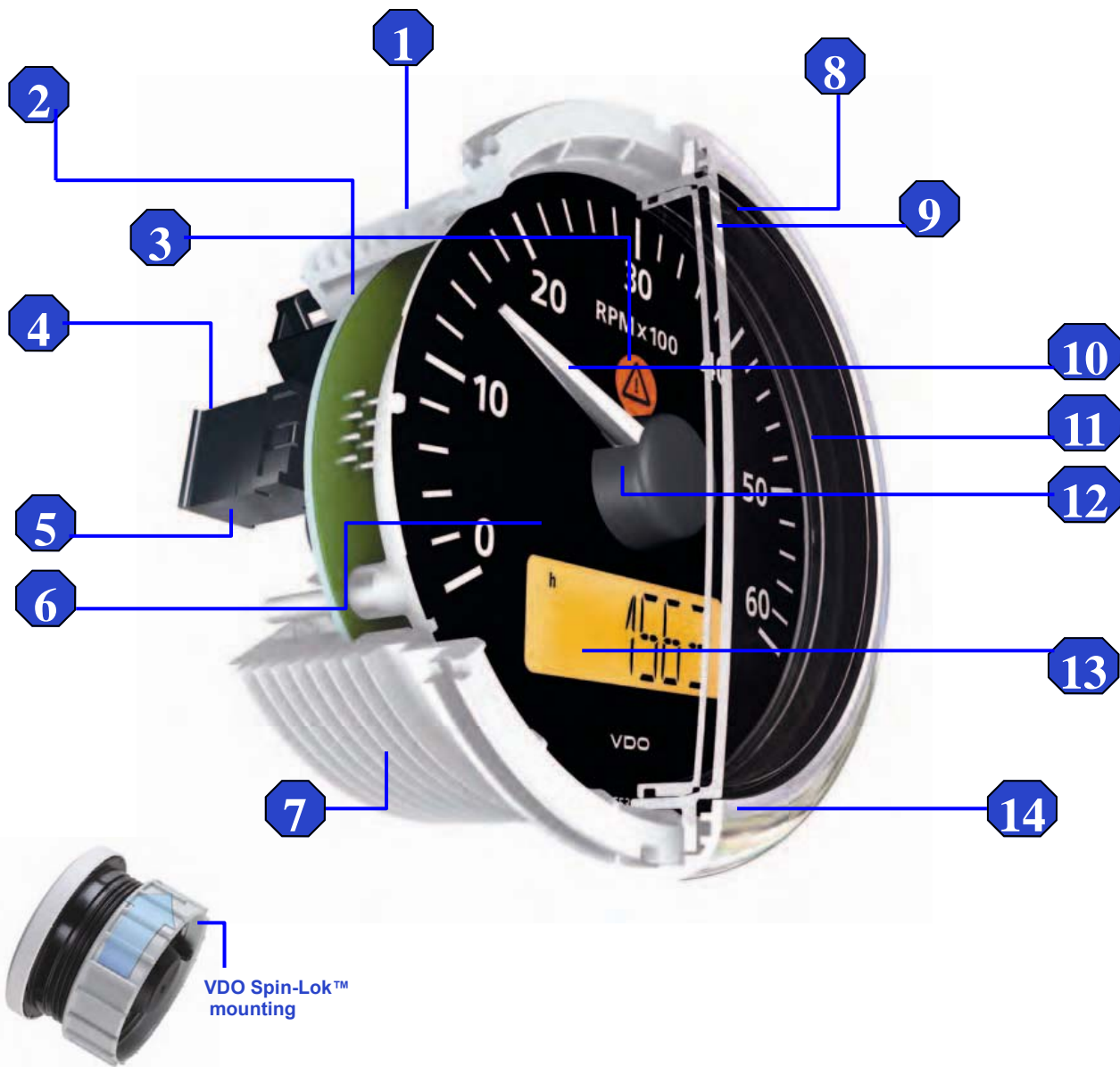

1. Spin-Lok mounting – a VDO innovation developed to safeguard against mounting panel warping and makes fast installation.
2. Single PCB increases reliability and minimizes instrument depth.
3. Built-in LED warning indicator (up to 5) is programmable to OEM-specified function.
4. Single cavity connectors reduce wiring installation time.
5. Reverse polarity and over voltage protection virtually eliminate the possibility of installation failures.
6. VDO is one of the few companies in the world to design, patent and manufacture stepper motors and resistive movements.
7. Corrosion-free and flame retardant materials comply with manufacturer's latest specifications.
8. Laser welded lenses ensure the highest level of protection against water intrusion.
9. Dual domed lenses eliminate fogging – another VDO innovation.
10. LED lit pointers and through dial lighting" minimize current consumption while optimizing nighttime viewing. "
11. Detail finish ring enhances the overall appearance of finished instrument – a VDO exclusive.
12. Designed to withstand continuous 25 G vibrations and 100 G single shock, to ensure maximum reliability of each instrument.
13. Large, multifunction backlit LCD provides easy readout of programmed functions.
14. Customer installed bezels with nine style choices allow for greater styling differentiation between product lines.

Viewline Gauges



Benefiting in the long-term from new technologies In developing the Viewline instrumentation, we have paid attention to the requirements of manufacturers. With Viewline, we have created a platform-wide standard with which we offer maximum freedom in respect of cockpit design.



Highly visible LED warning and indicator lights

Viewline instruments are fitted with highly visible, high intensity LED warning and indicator lights.

They ensure that critical operating conditions can be quickly and safely detected.



Clip-on bezel

The modular bezel concept offers design flexibility in the layout of instrument panels.

Three attractive design variants in black, white or chrome perfectly complement any boat's interior.

Furthermore, bezels are available in flat, round and triangular versions. All available bezels can be combined with all devices.

Viewline Gauges



Viewline Black



Viewline White



Sumlog & Tachourmeter

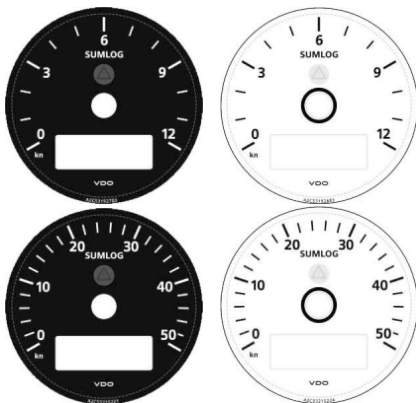

Speed
Total & Trip Distance
Depth
Sea Water Temperature
Clock
Voltmeter
External Trip-reset Button
External Mode Button



Through-Hull Kit



Transom Kit

Sumlog				Ø 80/85 mm
Part Number	Colour Dial/ Bezel	Range	Voltage	Smart Transducer
A2C59512404	Black	0 - 12 Kn	12/24V	See below
A2C59512407	White	0 - 12 Kn	12/24V	See below
A2C59512405	Black	0 - 50 Kn	12/24V	See below
A2C59512408	White	0 - 50 Kn	12/24V	See below

Transducer : Speed - Depth - Sea Water Temp				
Part Number	Range	Description	Cable Length	Connector
1501120004	0 - 12 Kn	Transom Kit A	10 m	Blue White Red Black/Shield NMEA0183 + NMEA0183 - + 12/24V Negative
X11719000053	0 - 50 Kn	Transom Kit	10 m	Blue White Red Black/Shield NMEA0183 + NMEA0183 - + 12/24V Negative
X11719000058	0 - 50 Kn	Through-Hull Kit B	10 m	Blue White Red Black/Shield NMEA0183 + NMEA0183 - + 12/24V Negative
A2C59513503		Loom	0.3 m	Connection between Transducer p/n X11719000053 or p/n X11719000058 and Sumlog head.

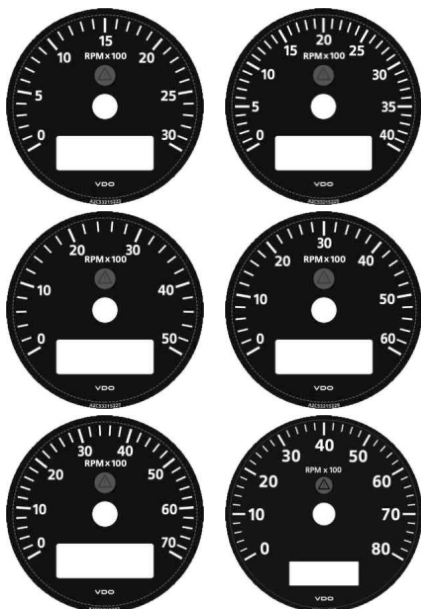

Engine Speed (RPM)
Total & Trip Hours
Clock
Voltmeter
External Trip-reset Button
External Mode Button
Programmable External Alarm

Tachourmeter				Ø 80/85 mm
Part Number	Colour Dial/ Bezel	Range	Voltage	Applicable Signal
A2C59512390	Black	0-3000 RPM	12/24V	Alternator Ignition Coil Generator Inductive
A2C59512391	Black	0-4000 RPM	12/24V	Alternator Ignition Coil Generator Inductive
A2C59512392	Black	0-5000 RPM	12/24V	Alternator Ignition Coil Generator Inductive
A2C59512393	Black	0-6000 RPM	12/24V	Alternator Ignition Coil Generator Inductive
A2C59512394	Black	0-7000 RPM	12/24V	Alternator Ignition Coil Generator Inductive
A2C59512395	Black	0-8000 RPM	12/24V	Alternator Ignition Coil Generator Inductive

Tachourmeter & Tachometer

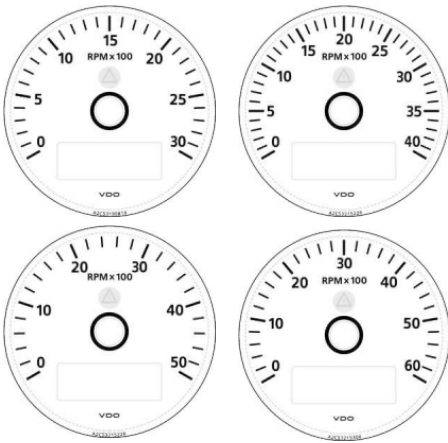

Engine Speed (RPM)
Total & Trip Hours
Clock
Voltmeter
External Trip-reset Button
External Mode Button
Programmable External Alarm

Tachourmeter				Ø 80/85 mm
Part Number	Colour Dial/ Bezel	Range	Voltage	Applicable Signal
A2C59512396	White	0-3000 RPM	12/24V	Alternator, Ignition Coil Generator, Inductive
A2C59512397	White	0-4000 RPM	12/24V	Alternator Ignition Coil Generator Inductive
A2C59512398	White	0-5000 RPM	12/24V	Alternator, Ignition Coil Generator, Inductive
A2C59512399	White	0-6000 RPM	12/24V	Alternator Ignition Coil Generator Inductive

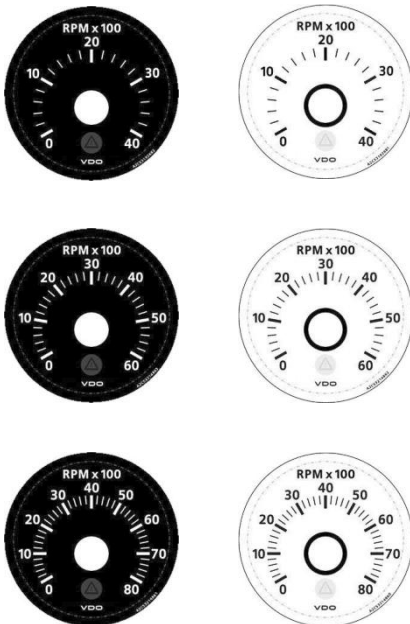

Engine Speed (RPM)

Tachometer				Ø 52 mm
Part Number	Colour Dial/ Bezel	Range	Voltage	Applicable Signal
A2C59512344	Black	0-4000 RPM	12/24V	Outboard Alternator Ignition Coil (Note: Alternator signal calibration via software, only).
A2C59512345	Black	0-6000 RPM	12/24V	Outboard Alternator Ignition Coil (Note: Alternator signal calibration via software, only).
A2C59512346	Black	0-8000 RPM	12/24V	Outboard Alternator Ignition Coil (Note: Alternator signal calibration via software, only).
A2C59512347	White	0-4000 RPM	12/24V	Outboard Alternator Ignition Coil (Note: Alternator signal calibration via software, only).
A2C59512348	White	0-6000 RPM	12/24V	Outboard Alternator Ignition Coil (Note: Alternator signal calibration via software, only).
A2C59512349	White	0-8000 RPM	12/24V	Outboard Alternator Ignition Coil (Note: Alternator signal calibration via software, only).

Note: The tachometer (without LCD) calibration for alternator application, can only be done using a TTL - 232R-5V loom and Viewline calibration software available from Continental Pty Ltd.

The tachometer will not work with Inductive or AC-Generator signals. For an inductive or AC generator signals use a Tachourmeter (with LCD display).

Tachometer

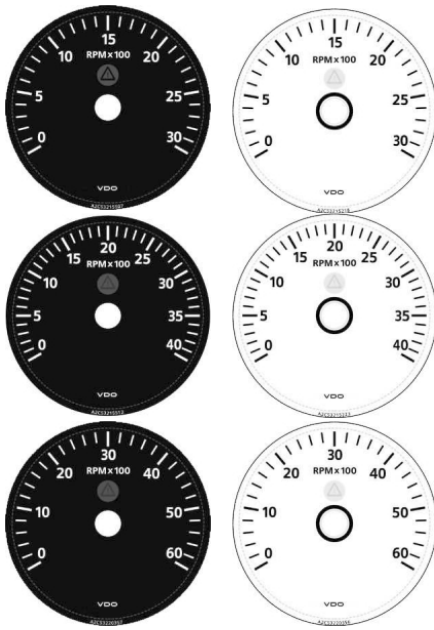

**Engine Speed (RPM)
Programmable Alarm (Software)**

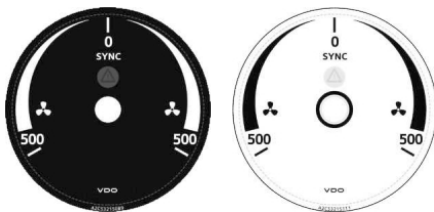

Differential Engine Speed (RPM)

Tachometer

Ø 80/85 mm

Part Number	Colour Dial/ Bezel	Range	Voltage	Applicable Signal
A2C59512430	Black	0-3000 RPM	12/24V	Outboard Alternator Ignition Coil (Note: Alternator signal calibration via software, only. Contact a VDO Service Agent for assistance)
A2C59512431	Black	0-4000 RPM	12/24V	Outboard Alternator Ignition Coil (Note: Alternator signal calibration via software, only. Contact a VDO Service Agent for assistance)
A2C59512432	Black	0-6000 RPM	12/24V	Outboard Alternator Ignition Coil (Note: Alternator signal calibration via software, only. Contact a VDO Service Agent for assistance)
A2C59512433	White	0-3000 RPM	12/24V	Outboard Alternator Ignition Coil (Note: Alternator signal calibration via software, only. Contact a VDO Service Agent for assistance)
A2C59512434	White	0-4000 RPM	12/24V	Outboard Alternator Ignition Coil (Note: Alternator signal calibration via software, only. Contact a VDO Service Agent for assistance)
A2C59512435	White	0-6000 RPM	12/24V	Outboard Alternator Ignition Coil (Note: Alternator signal calibration via software, only. Contact a VDO Service Agent for assistance)

Note: The tachometer (without LCD) calibration for alternator application, can only be done using a TTL - 232R-5V loom and Viewline calibration software available from Continental Pty Ltd.

The tachometer will not work with Inductive or AC-Generator signals. For an inductive or AC generator signals use a Tachourmeter (with LCD display).

Synchroniser Tachometer

Ø 80/85 mm

Part Number	Colour Dial/ Bezel	Range	Voltage	Applicable Signal
A2C59512402	Black	+/- 0-500 RPM	12/24V	Alternator Ignition Coil Generator Inductive
A2C59512403	White	+/- 0-500 RPM	12/24V	Alternator Ignition Coil Generator Inductive

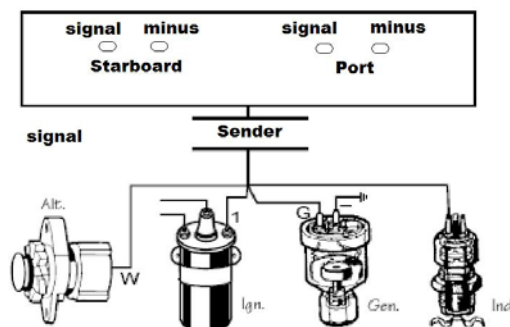

Temperature

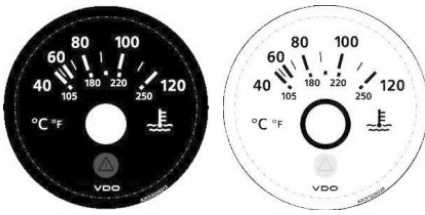

Temperature Gauge Water Ø 52 mm

Part Number	Colour Dial/ Bezel	Range	Voltage	Ohms Range
A2C59512548	Black	40 - 120C (250F)	12V <small>(for 24V with dropping voltage resistor p/n A2C59510853)</small>	282 - 22 Ohms 38.6 Ohms = 100C
A2C59512555	White	40 - 120C (250F)	12V <small>(for 24V with dropping voltage resistor p/n A2C59510853)</small>	282 - 22 Ohms 38.6 Ohms = 100C

Temperature Sender Water



Part Number	Range	Thread size	Connector
323805001001K	40 - 120C (250F)	M14x1.5	2 spade terminals
323805001015N	40 - 120C (250F)	M18x1.5	2 spade terminals
323805001004K	40 - 120C (250F)	1/2"-14NPTF	2 spade terminals
323805001007N	40 - 120C (250F)	1/4"-18NPTF	2 spade terminals
323805001005N	40 - 120C (250F)	3/8"-18NPTF	2 spade terminals
323805001002C	40 - 120C (250F)	5/8"-18UNF 2A	2 spade terminals



Note: For single terminals (earth return) or dual station senders, refer appendix on page 38 - 39

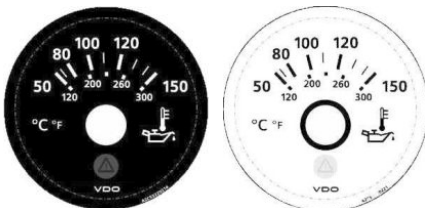

Temperature Gauge Engine Ø 52 mm

Part Number	Colour Dial/ Bezel	Range	Voltage	Ohms Range
A2C59512550	Black	50 - 150C (300F)	12V <small>(for 24V with dropping voltage resistor p/n A2C59510853)</small>	323 - 18 Ohms 62.2 Ohms = 100C
A2C59512556	White	50 - 150C (300F)	12V <small>(for 24V with dropping voltage resistor p/n A2C59510853)</small>	323 - 18 Ohms 62.2 Ohms = 100C

Temperature Sender Engine



Part Number	Range	Thread size	Connector
323805001001K	50 - 150C (300F)	M14x1.5	2 spade terminals
323805001007N	50 - 150C (300F)	1/4"-18NPTF	2 spade terminals



Note: For single terminals (earth return) or dual station senders, refer appendix on page 38 - 39

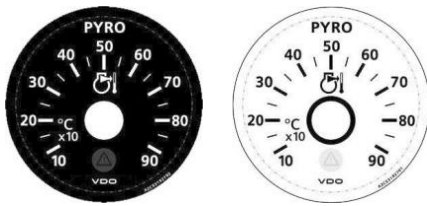

Pyrometer Gauge -

Ø 52 mm

Part Number	Colour Dial/ Bezel	Range	Voltage	mV Range
A2C59512332	Black	100 - 900C (1650F)	12/24V	4.04 - 37.5 mV
A2C59512333	White	100 - 900C (1650F)	12/24V	4.04 - 37.5 mV
A2C59512334	Black	212 - 1650F (900C)	12/24V	4.04 - 37.5 mV
A2C59512335	White	212 - 1650F (900C)	12/24V	4.04 - 37.5 mV

Thermocouple K Type Kit (no gauge)



Part Number	Description	Range	Terminals
320.714	Thermocouple Probe	100 - 900C (1650F)	Red = Negative Yellow = Positive
240.035	Compensating Cable	5 metres	White = Negative Blue = Positive or Red = Negative Brown = Positive

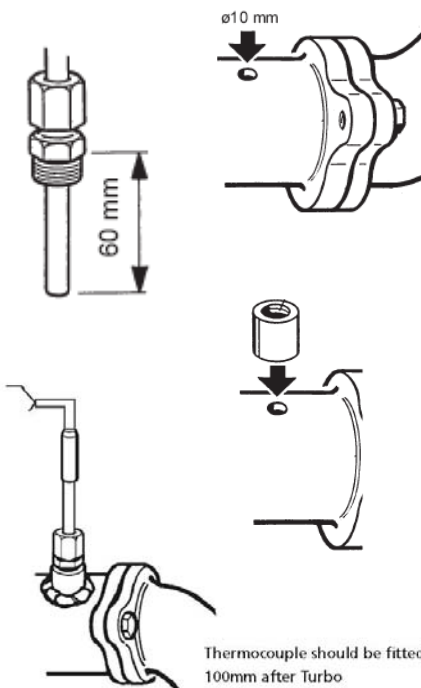

Install the sensor in the exhaust pipe near the elbow flange.

Maximum adjustment depth up to the middle of exhaust pipe: 60 mm.

Mount the bushing centrally and weld on.

The weld must form a tight seal.

K Type thermocouple Calibration Chart

Degrees Celsius	Probe Voltage (mV)
100	4.04
200	8.137
300	12.20
400	16.4
500	20.64
600	24.902
700	29.128
800	33.277
900	37.325

Celsius to Fahrenheit Conversion Chart

Degrees Celsius	Degrees Fahrenheit
100	212
200	392
300	572
400	752
500	932
600	1112
700	1292
800	1472
900	1650

Outside Temp & Turbo Pressure

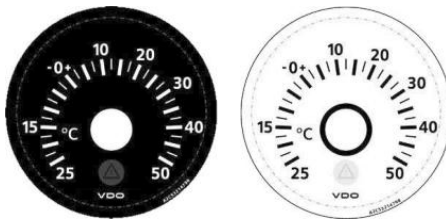

Outside Air Temperature				Ø 52 mm
Part Number	Colour Dial Bezel	Range	Voltage	Ohms
A2C59512336	Black	-25to+50C	12/24V	0°C = 4082 Ohms
A2C59512338	White	-25to+50C	12/24V	0°C = 4082 Ohms

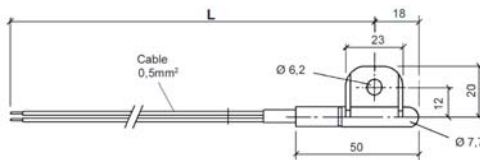

Temperature Sender Air			
Part Number	Range	Cable Length	Wires
323809010006C	-25to+50C	L = 4500mm	Green Signal Brown Negative

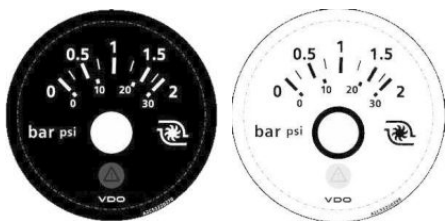

Pressure Gauge Turbo 2 Bar				
Part Number	Colour Dial/ Bezel	Range	Voltage	Ohms Range
A2C59512599	Black	0 - 2 Bar (28 Psi)	12V <small>(for 24V with dropping voltage resistor p/n A2C59510853)</small>	10 - 183 Ohms 0-2 Bar
A2C59512617	White	0 - 2 Bar (28 Psi)	12V <small>(for 24V with dropping voltage resistor p/n A2C59510853)</small>	10 - 183 Ohms 0-2 Bar



Pressure Sender 2 Bar			
Part Number	Range	Thread size	Connector
360081032025C	0 - 2 Bar (28 Psi)	1/8"-27NPTF	2 x M4 Screws
360081032011C	0 - 2 Bar (28 Psi)	M12x1.5	2 x M4 Screws

Note: For single terminals (earth return) or dual station senders, refer to pages 36 - 37

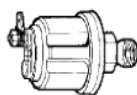

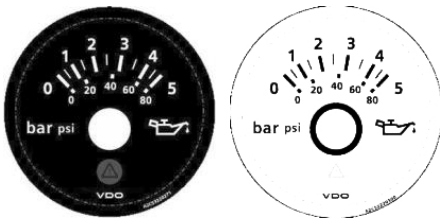

Pressure Gauge Engine Oil Ø 52 mm

Part Number	Colour Dial Bezel	Range	Voltage	Ohms Range
A2C59512601	Black	0 - 5 Bar (72 Psi)	12V <small>(for 24V with dropping voltage resistor p/n A2C59510853)</small>	0 Bar = 10 5 Bar = 183
A2C59512618	White	0 - 5 Bar (72 Psi)	12V <small>(for 24V with dropping voltage resistor p/n A2C59510853)</small>	0 Bar = 10 5 Bar = 183



Pressure Sender Engine Oil

Part Number	Range	Thread size	Connector
360081032002C	0 - 5 Bar (72 Psi)	M10x1	2 Screw terminals
360081032001C	0 - 5 Bar (72 Psi)	1/8"-27NPTF	2 Screw terminals

Note: For single terminals (earth return) or dual station senders, refer to pages 36 - 37

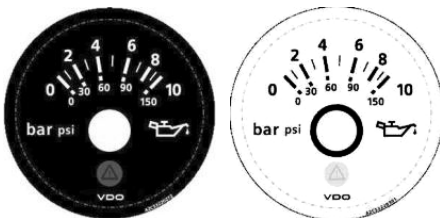
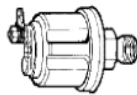

Pressure Gauge Engine Oil Ø 52 mm

Part Number	Colour Dial Bezel	Range	Voltage	Ohms Range
A2C59512603	Black	0 - 10 Bar (150 Psi)	12V <small>(for 24V with dropping voltage resistor p/n A2C59510853)</small>	0 Bar = 10 10 Bar = 183
A2C59512619	White	0 - 10 Bar (150 Psi)	12V <small>(for 24V with dropping voltage resistor p/n A2C59510853)</small>	0 Bar = 10 10 Bar = 183

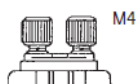

Pressure Sender Engine Oil

Part Number	Range	Thread size	Connector
360081032003C	0 - 10 Bar (150 Psi)	M10x1	2 Screw terminals
360081032006C	0 - 10 Bar (150 Psi)	M14x1.5	2 Screw terminals
360081032014C	0 - 10 Bar (150 Psi)	1/8"-27NPTF	2 Screw terminals

Note: For single terminals (earth return) or dual station senders, refer to pages 36 - 37

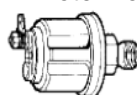

Transmission Pressure

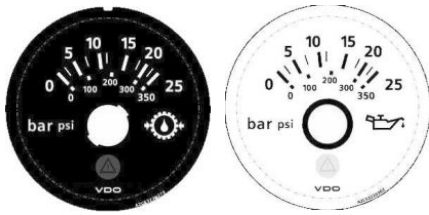

Pressure Gauge Transmission Ø 52 mm

Part Number	Colour Dial Bezel	Range	Voltage	Ohms Range
A2C59512605	Black	0 - 25 Bar (400 Psi)	12V <small>(for 24V with dropping voltage resistor p/n A2C59510853)</small>	0 Bar = 10 25 Bar = 183
A2C59512620	White	0 - 25 Bar (400 Psi)	12V <small>(for 24V with dropping voltage resistor p/n A2C59510853)</small>	0 Bar = 10 25 Bar = 183

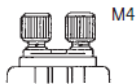

Pressure Sender Transmission

Part Number	Range	Thread size	Connector
360081038001C	0 - 25 Bar (400 Psi)	M14x1.5	2 Screw terminals
360081038003C	0 - 25 Bar (400 Psi)	1/8"-27NPTF	2 Screw terminals
360081038002C	0 - 25 Bar (400 Psi)	3/8"-18NPTF	2 Screw terminals

Note: For single terminals (earth return) or dual station senders, refer to pages 36 - 37

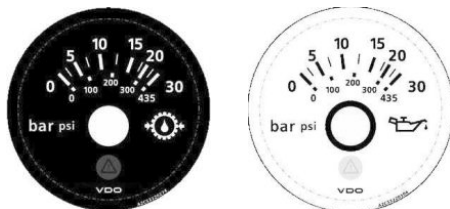
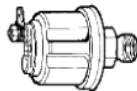

Pressure Gauge Transmission Ø 52 mm

Part Number	Colour Dial Bezel	Range	Voltage	Ohms Range
A2C59512607	Black	0 - 30 Bar (435 Psi)	12V <small>(for 24V with dropping voltage resistor p/n A2C59510853)</small>	0 Bar = 10 30 Bar = 183
A2C59512621	White	0 - 30 Bar (435 Psi)	12V <small>(for 24V with dropping voltage resistor p/n A2C59510853)</small>	0 Bar = 10 30 Bar = 183

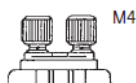

Pressure Sender Transmission

Part Number	Range	Thread size	Connector
360081038001C	0 - 30Bar (435 Psi)	M14x1.5	2 Screw terminals
360081038003C	0 - 30Bar (435 Psi)	1/8"-27NPTF	2 Screw terminals
360081038002C	0 - 30 Bar (435 Psi)	3/8"-18NPTF	2 Screw terminals

Note: For single terminals (earth return) or dual station senders, refer to pages 36 - 37

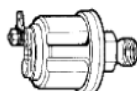

***For 30 Bar pressure sender's range, use 25 Bar senders**

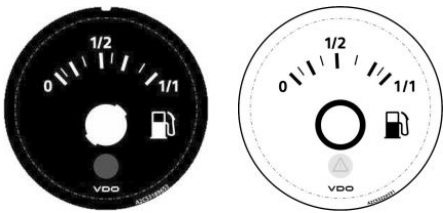

Fuel Gauge

Ø 52 mm

Part Number	Colour Dial Bezel	Range	Voltage	Ohms Range
A2C59512497	Black	0 - 1	12V <small>(for 24V with dropping voltage resistor p/n A2C59510853)</small>	Empty = 3 Full = 180
A2C59512508	White	0 - 1	12V <small>(for 24V with dropping voltage resistor p/n A2C59510853)</small>	Empty = 3 Full = 180

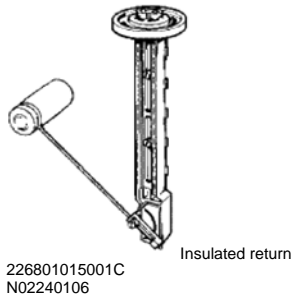

Sender Float Arm - Fuel Pitch 54 mm

Part Number	Range	Notes	Terminal
226801015001C	3-180 Ohms	Adjustable 200-600mm	Spade x2
N02240106	5-90 Ohms	Adjustable 200-600mm	Spade x2
A2C59510165	3-180 Ohms	Sender with low fuel warning switch. Adjustable 150-535mm	Spade x3
A2C59510171	3-180 Ohms	Arm Type Fuel Sender Adjustable 150-535mm	Spade x2
A2C59510166	5-90 Ohms	Sender with low fuel warning switch. Adjustable 150-535mm	Spade x3
A2C59510172	5-90 Ohms	Arm Type Fuel Sender Adjustable 150-535mm	Spade x2
A2C59510167	240-33 Ohms	Sender with low fuel warning switch. Adjustable 150-535mm	Spade x3
A2C59510173	240-33 Ohms	Arm Type Fuel Sender Adjustable 150-535mm	Spade x2

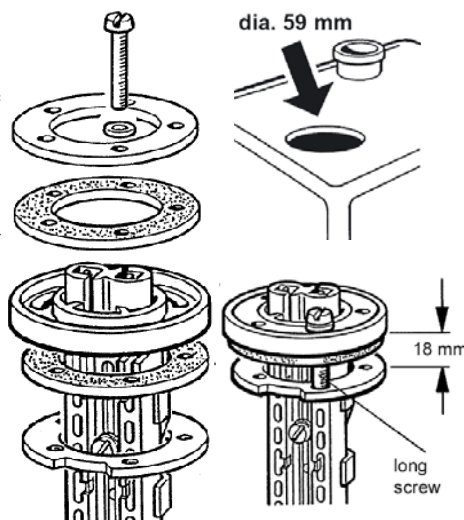
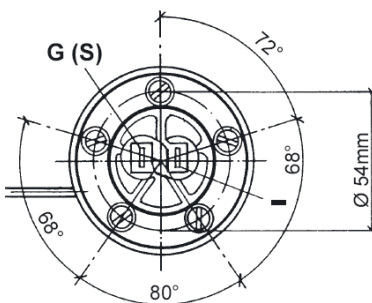

with slit must be inserted first

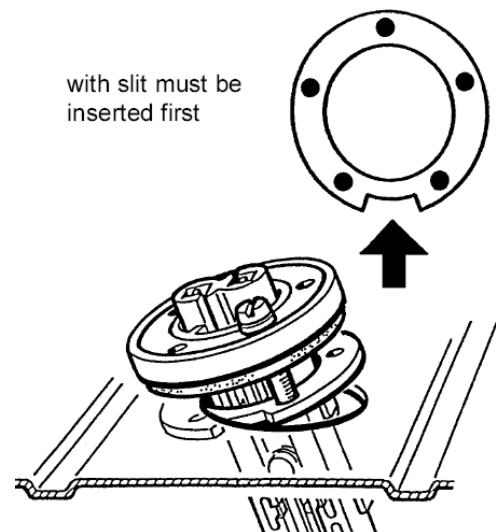

Note: Use adaptor plate p/n CTA0200 when installing the five holes sender's plate on to 6 holes applications.

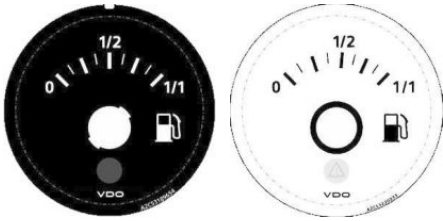

Fuel Gauge

Ø 52 mm

Part Number	Colour Dial Bezel	Range	Voltage	Ohms Range
A2C59512497	Black	0 - 1	12V <small>(for 24V with dropping voltage resistor p/n A2C59510853)</small>	Empty = 3 Full = 180
A2C59512508	White	0 - 1	12V <small>(for 24V with dropping voltage resistor p/n A2C59510853)</small>	Empty = 3 Full = 180

Note: All Reed Switch senders on the list below have a Low Fuel Warning switch, except the 150 & 180 mm length (marked *)

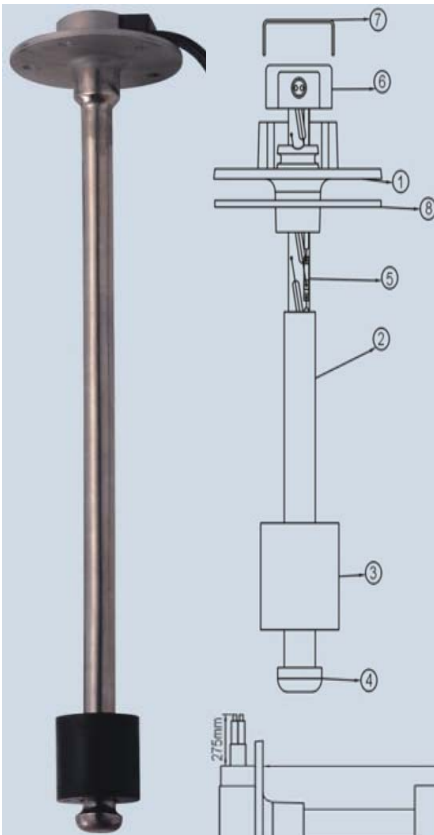

Sender Reed Switch - Fuel Pitch 54 mm

Part Number	Range E - F	L = length
220.150-180	3-180 Ohms	150 mm *
220.180-180	3-180 Ohms	180 mm *
220.230-180	3-180 Ohms	230 mm
220.250-180	3-180 Ohms	250 mm
220.260-180	3-180 Ohms	260 mm
220.270-180	3-180 Ohms	270 mm
220.300-180	3-180 Ohms	300 mm
220.320-180	3-180 Ohms	320 mm
220.330-180	3-180 Ohms	330 mm
220.350-180	3-180 Ohms	350 mm
220.600-180	3-180 Ohms	600 mm
220.660-180	3-180 Ohms	660 mm

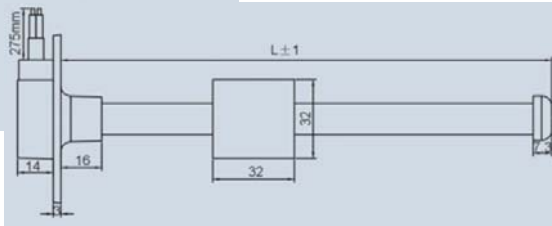

Item #	Qty	Description	Material
1	1	Sensor Head	S/Steel 316
2	1	Reed Sw Tube	S/Steel 316
3	1	Float 32x32mm	Acrylon NBR
4	1	Bottom plug	S/Steel 316
5	1	Reed Sw assy	NBR 60
6	1	Rubber	
7	1	Cover	Alum
8	1	Gasket 68x2mm	NBR 60

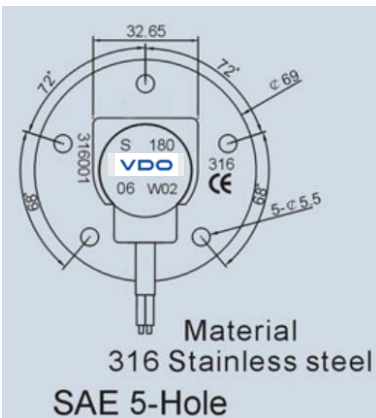

Note: Use adaptor plate p/n CTA0200 when installing the five holes sender's plate on to 6 holes applications.

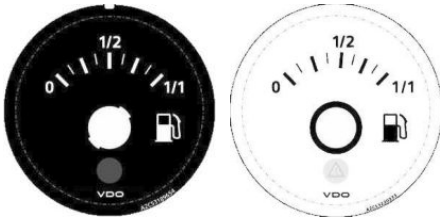

Fuel Gauge Tubular Type

Part Number	Colour Dial Bezel	Range	Voltage	Ohms Range
A2C59512499	Black	0 - 1/1	12V <small>(for 24V with dropping voltage resistor p/n A2C59510853)</small>	Empty = 110 / 50 Full = 2
A2C59512509	White	0 - 1/1	12V <small>(for 24V with dropping voltage resistor p/n A2C59510853)</small>	Empty = 110 / 50 Full = 2



Sender Tubular Type - Fuel Pitch 54 mm

Sender Part No.	Length	Sender Part No.	Length
224011000015G	150mm	224011000032G	320mm
224011000016G	160mm	224011000033G	330mm
224011000017G	170mm	224011000034G	340mm
224011000018G	180mm	224011000035G	350mm
224011000019G	190mm	224011000036G	360mm
224011000020G	200mm	224011000037G	370mm
224011000021G	210mm	224011000038G	380mm
224011000022G	220mm	224011000039G	390mm
224011000023G	230mm	224011000040G	400mm
224011000024G	240mm	224011000045G	450mm
224011000025G	250mm	224011000050G	500mm
224011000026G	260mm	224011000055G	550mm
224011000027G	270mm	224011000060G	600mm
224011000028G	280mm	224011000065G	650mm
224011000029G	290mm	224011000070G	700mm
224011000030G	300mm	224011000075G	750mm
224011000031G	310mm	224011000080G	800mm

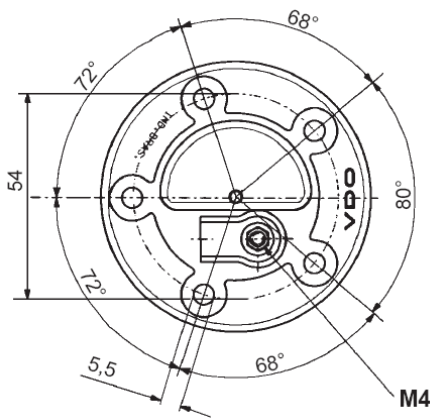

dia. 59 mm

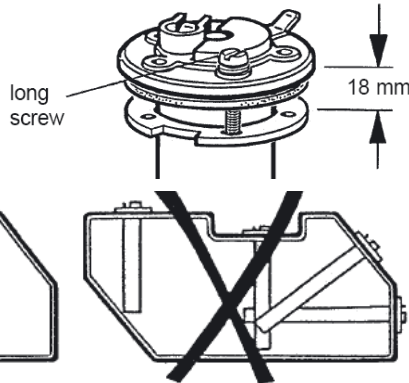
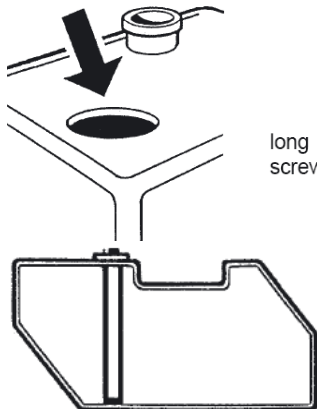

with slit must be inserted first

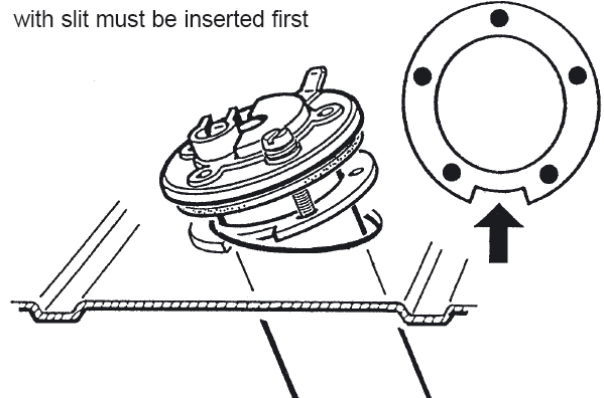

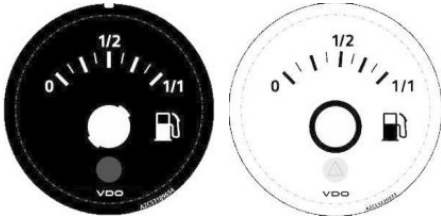

Fuel Gauge Tubular Type

Part Number	Colour Dial Bezel	Range	Voltage	Ohms Range
A2C59512499	Black	0 - 1/1	12V (for 24V with dropping voltage resistor p/n A2C59510853)	Empty = 110 / 50 Full = 2
A2C59512509	White	0 - 1/1	12V (for 24V with dropping voltage resistor p/n A2C59510853)	Empty = 110 / 50 Full = 2

Sender Tubular Type - Fuel Pitch 80 mm



Sender Part No.	Length	Sender Part No.	Length
X10224014031	326 mm	X10224009026	831 mm
X10224014021	426 mm	X10224021006	846 mm
X10224009037	536 mm	X10224014003	881 mm
X10224009053	551 mm	X10224014011	916 mm
X10224009039	596 mm	X10224009057	946 mm
X10224021002	596 mm	X10224014015	996 mm
X10224014022	616 mm	X10224009022	1001 mm
X10224009048	641 mm	X10224021005	1045 mm
X10224014002	686 mm	X10224009040	1086 mm
X10224009029	741 mm	X10224014044	1250 mm
X10224009019	781 mm	X10224009072	1387 mm
X10224021004	803 mm	-----	-----

Accessories:

p/n 115910011401 Welding Flange Ø80mm
p/n 2251016 Gasket Cork Ø80mm

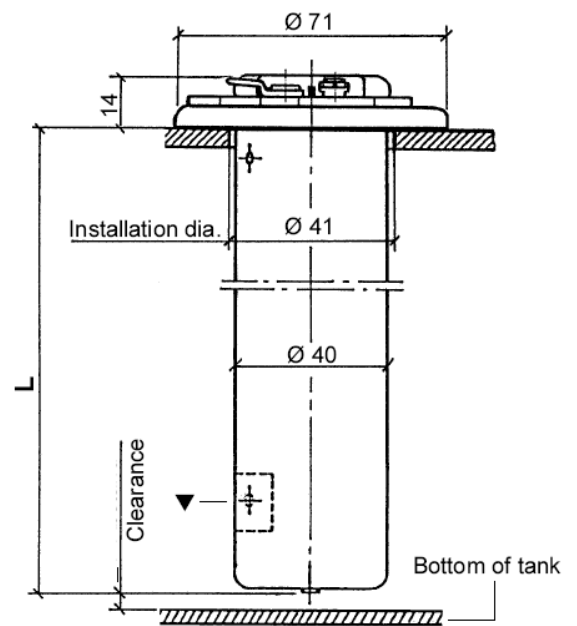
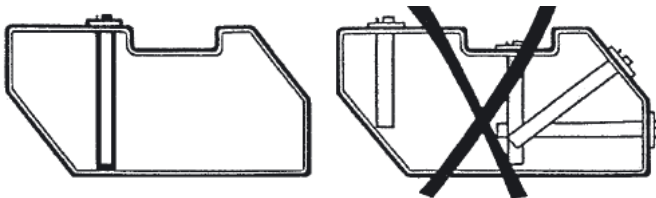
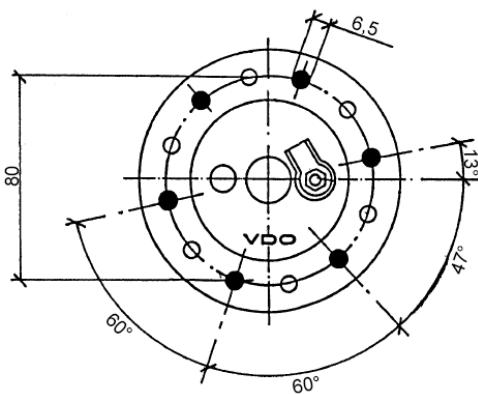

Fuel Gauge - US Senders

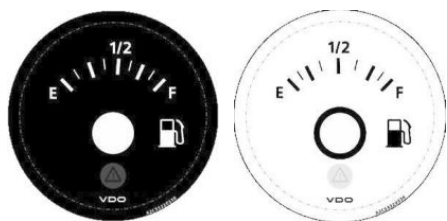

Fuel Gauge (US Application)				Ø 52 mm
Part Number	Colour Dial / Bezel	Range	Voltage	Ohms Range
A2C59512505	Black	E -1/2 - F	12V <small>(for 24V with dropping voltage resistor p/n A2C59510853)</small>	Empty = 5 Full = 90
A2C59512511	White	E -1/2 - F	12V <small>(for 24V with dropping voltage resistor p/n A2C59510853)</small>	Empty = 5 Full = 90
A2C59512503	Black	E -1/2 - F	12V <small>(for 24V with dropping voltage resistor p/n A2C59510853)</small>	Empty= 240 Full = 33
A2C59512510	White	E -1/2 - F	12V <small>(for 24V with dropping voltage resistor p/n A2C59510853)</small>	Empty= 240 Full = 33



Lever Fuel Sensor - without low fuel alarm			
Part Number	Ohms Range	Adjustable	Pitch Ø
220.004	5 - 90	145 - 400 mm	54 mm
220.005	240 -33	145 - 400 mm	54 mm



Lever Fuel Sensor - with low fuel alarm			
Part Number	Ohms Range	Adjustable	Pitch Ø
A2C59510166	240 - 33	145 - 400 mm	54 mm
A2C59510167	0 - 90	145 - 400 mm	54 mm

Lever Fuel Sensor - without low fuel alarm			
Part Number	Ohms Range	Ohms Range	Pitch Ø
A2C59510172	240 - 33	145 - 400 mm	54 mm
A2C59510173	0 - 90	145 - 400 mm	54 mm



Tank Sender Accessories	
Part No.	Description.
N05801432	Flange Kit Bolt Circle Ø54mm
22502641141	Bolt Circle Ø54mm
224011000017G	Bolt Circle Ø80mm
CTA0200	Six to five holes conversion plate

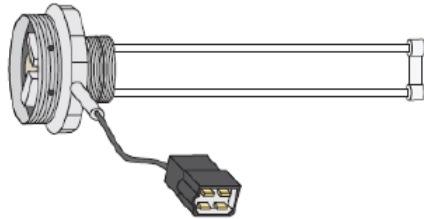
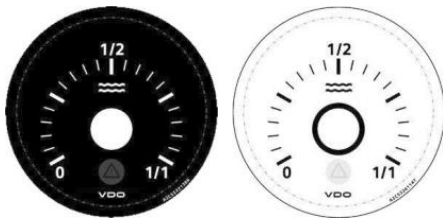

Fresh Water Level Gauge

Ø 52 mm

Part Number	Colour Dial Bezel	Range	Voltage	Range
A2C59512340	Black	0 - 1/1	12V	Empty = 4 mA Full = 20 mA
A2C59512341	White	0 - 1/1	12V	Empty = 4 mA Full = 20 mA

Fresh Water Sender 4 - 20 mA

Part Number	Range E - F	Adjustable length	Terminal
N02240902	0 - 100%	80 - 600 mm	Water-Proof Plug
N02240904	0 - 100%	600 - 1200 mm	Water-Proof Plug
N02240906	0 - 100%	1200 - 1500 mm	Water-Proof Plug
X10224000007	Tank unit flange with Gasket		

Fresh Water Level Gauge

Ø 52 mm

Part Number	Colour Dial Bezel	Range	Voltage	Range
A2C59510366	Black	0 - 1/1	12V	Empty = 3 Ohms Full = 180 Ohms
A2C59510368	White	0 - 1/1	12V	Empty = 3 Ohms Full = 180 Ohms

Sender Reed Switch - Water Pitch 54 mm

Part Number	Range E - F	L = length	Terminal
220.150-180	3-180 Ohms	150 mm	Water-Proof Plug
220.180-180	3-180 Ohms	180 mm	Water-Proof Plug
220.230-180	3-180 Ohms	230 mm	Water-Proof Plug
220.260-180	3-180 Ohms	260 mm	Water-Proof Plug
220.270-180	3-180 Ohms	270 mm	Water-Proof Plug
220.300-180	3-180 Ohms	300 mm	Water-Proof Plug
220.320-180	3-180 Ohms	320 mm	Water-Proof Plug
220.330-180	3-180 Ohms	330 mm	Water-Proof Plug
220.600-180	3-180 Ohms	600 mm	Water-Proof Plug
220.660-180	3-180 Ohms	660 mm	Water-Proof Plug



Waste Water & Hourmeter

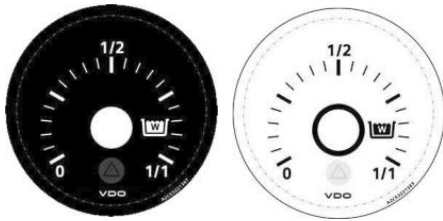

Waste Water Level Gauge				Ø 52 mm
Part Number	Colour Dial Bezel	Range	Voltage	Range
A2C59512342	Black	0 - 1/1	12V	Empty = 4 mA Full = 20 mA
A2C59512343	White	0 - 1/1	12V	Empty = 3 Ohms Full = 180 Ohms

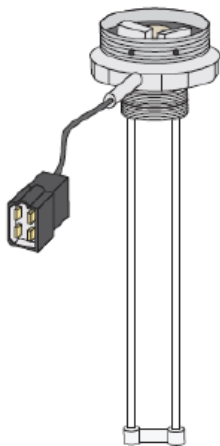

Waste Water Sender 4 - 20 mA			
Part Number	Range E - F	Adjustable length	Terminal
N02240902	Empty = 4 mA Full = 20 mA	80 - 600 mm	Water-Proof Plug
N02240904	Empty = 4 mA Full = 20 mA	600 - 1200 mm	Water-Proof Plug
N02240906	Empty = 4 mA Full = 20 mA	1200 - 1500 mm	Water-Proof Plug

Accessory	
Part Number	Description
X1022400007	Tank unit flange with Gasket

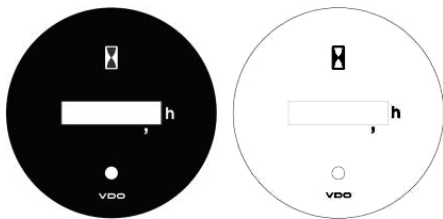

Hourmeter			
Part Number	Colour Dial/ Bezel	Light	Voltage
A2C59512453	Black	Yes	12/24V
A2C59512454	White	Yes	12/24V



Pressure Switch - Heavy Duty					
Part Number	Switch Point Bar (Psi)	Thread Size	Terminals	Picture	Switch Contact
230.050	0.5 Bar (7) Fixed	1/8"-27NPTF	Screw x 2 Insulated Return	A	N/O Raising Pressure

Volt & Ammeter

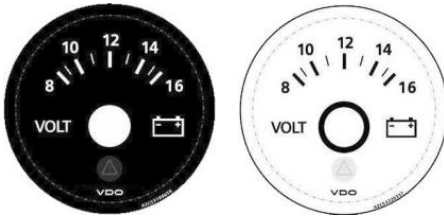

Voltmeter			Ø 52 mm
Part Number	Colour Dial / Bezel	Range	Voltage
A2C59512545	Black	8 -16V	12V
A2C59512546	White	8 -16V	12V
A2C59512458	Black	18 - 32V	24V
A2C59512459	White	18 - 32V	24V

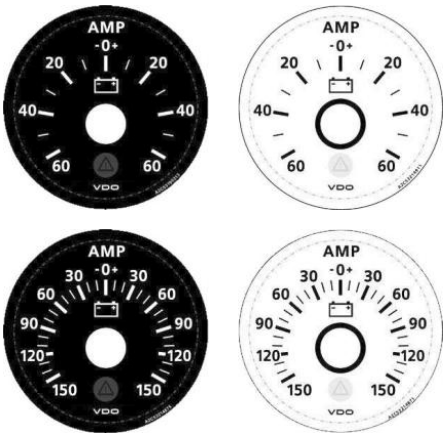

Ammeter Gauge with external shunt			Ø 52 mm
Part Number	Colour Dial / Bezel	Range	Voltage
A2C59512328	Black	60A	12/24V
A2C59512330	White	60A	12/24V
A2C59512329	Black	150A	12/24V
A2C59512331	White	150A	12/24V

Gauge does not include Current Sensor or Loom



Ammeter Shunt		
Part Number	Range / Description	Voltage
UK-UE-157	60A	12/24V
UK-UE-094	150A	12/24V
UK-UE-184	Shunt Harness	
UK-UE-188	Universal Mounting Bracket Kit	

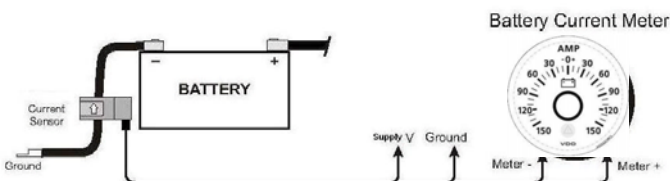

SENSOR Specs

Sensor Type: Open loop Hall-Effect
 Linearity: 1.5%
 Supply Voltage Range: 12/24V
 Current Consumption: 8.1 mA max
 Output to Gauge: + - 60 mV
 Operating Temp: 40°C to + 125°C
 Storage Temp: 40°C to + 125°C
 Aperture size: 31.24 mm
 Weight: 0.136 Kg
 Connector: Packard sealed Metri-Pak 150
 Note: Mating plug not supplied with sensor

Trim & Rudder Angle



Trim Gauge Ø 52 mm

Part Number	Colour Dial/ Bezel	Range	Voltage
A2C59512564	Black	Bravo Drive	12V

Note: Trim sensor for the Bravo drive is a Mercury product.



Rudder Angle Indicator Ø 52 mm

Part Number	Colour Dial/ Bezel	Range	Voltage
A2C59512561	Black	40° Stb	12V <small>(for 24V with dropping voltage resistor)</small>
A2C59512562	White	40° Stb	12V <small>(for 24V with dropping voltage resistor)</small>



Rudder Angle Indicator Ø 80/85 mm

Part Number	Colour Dial/ Bezel	Range	Voltage
A2C59512410	Black	+45°	12/24V
A2C59512411	White	+45°	12/24V



Rudder Angle Sender

Part Number		Voltage	Note
440102001001D	Single Station	12/24V	Sender suitable for 52 and 85mm gauges
440102002001D	Dual Station	12/24V	Dual station sender has a "D" market on the body



Clock Ø 52 mm

Part Number	Colour Dial/ Bezel	Range	Voltage
A2C59513445	Black	12h	12V
A2C59513443	White	12h	12V
A2C59513446	Black	12h	24V
A2C59513444	White	12h	24V

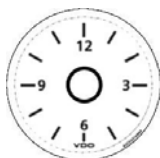



Engine Monitoring Master SAE J1939 Ø 80/85 mm

Part Number	Colour Dial/ Bezel	Description	Range	Voltage
N02012920	Black	Master Gauge	3000	12/24V
N02012922	Black	Master Gauge	4000	12/24V
N02012928	White	Master Gauge	3000	12/24V
N02012930	White	Master Gauge	4000	12/24V

Engine Monitoring Slave SAE J1939 Ø 52 mm

Part Number	Colour Dial/ Bezel	Description	Range	Voltage
N02140154	Black	Gearbox oil pressure gauge	25 bar	12/24V
N02140156	Black	Engine oil pressure gauge	10 bar	12/24V
N02140508	Black	Boost pressure gauge	3 bar	12/24V
N02140512	Black	Engine oil pressure gauge	150 psi	12/24V
N02140516	Black	Gearbox pressure gauge	360 psi	12/24V
N02224080	Black	Fuel tank gauge	0-4/4	12/24V
N02226002	Black	Engine load	0 - 100%	12/24V
N02270040	Black	Fuel flow gauge	80 l/h	12/24V
N02311054	Black	Engine oil temperature gauge	50 - 150°C	12/24V
N02311056	Black	Engine coolant temperature	40 - 120°C	12/24V
N02311536	Black	Gearbox oil temperature	50 - 150°C	12/24V
N02311540	Black	Exhaust gas temperature	100 - 900°C	12/24V
N02311544	Black	Gearbox oil temperature	120 - 300 °F	12/24V
N02311546	Black	Exhaust gas temperature	200 - 1700 °F	12/24V
N02311548	Black	Exhaust gas temperature, Turbine A	200 - 1700 °F	12/24V
N02311550	Black	Exhaust gas temperature, Turbine B	200 - 1700 °F	12/24V
N02311552	Black	Engine coolant temperature	100 - 250 °F	12/24V
N02311554	Black	Exhaust gas temperature, Turbine A	100 - 900 °C	12/24V
N02311556	Black	Exhaust gas temperature, Turbine B	100 - 900 °C	12/24V
N02413058	Black	Voltmeter	18 - 32 V	24V
N02413066	Black	Voltmeter	8 - 16 V	12V
N02311542	Black	Engine oil temperature	100 - 300 °F	12/24V
N02140158	White	Gearbox oil pressure gauge	25bar / 360psi	12/24V
N02140160	White	Engine oil pressure gauge	10bar / 145psi	12/24V
N02224082	White	Fuel tank gauge	0-4/4	12/24V
N02311058	White	Engine oil temperature gauge	150°C / 300°	12/24V
N02311060	White	Engine coolant temperature gauge	120°C / 250°F	12/24V
N02413060	White	Voltmeter	18-32 V	24V
N02413074	White	Voltmeter	8-16 V	12V



Low Level Warning Switch - Oil & Diesel

Part Number	Installation from	Contact mm L	Switch Load	Thread Size	Voltage
395462001001	Above	158	2W	M22x1.5	24V
395262001007	Above	170	2W	M22x1.5	12V
395462001006	Above	285	3W	M22x1.5	24V
395462001002	Below	35.6	3W	M22x1.5	24V
395262001005	Below	50	2W	M22x1.5	12V
395262001015	Below	73	2W	M22x1.5	12V
395462001004	Below	120	3W	M22x1.5	24V
395462001005	Below	150	3W	M22x1.5	24V

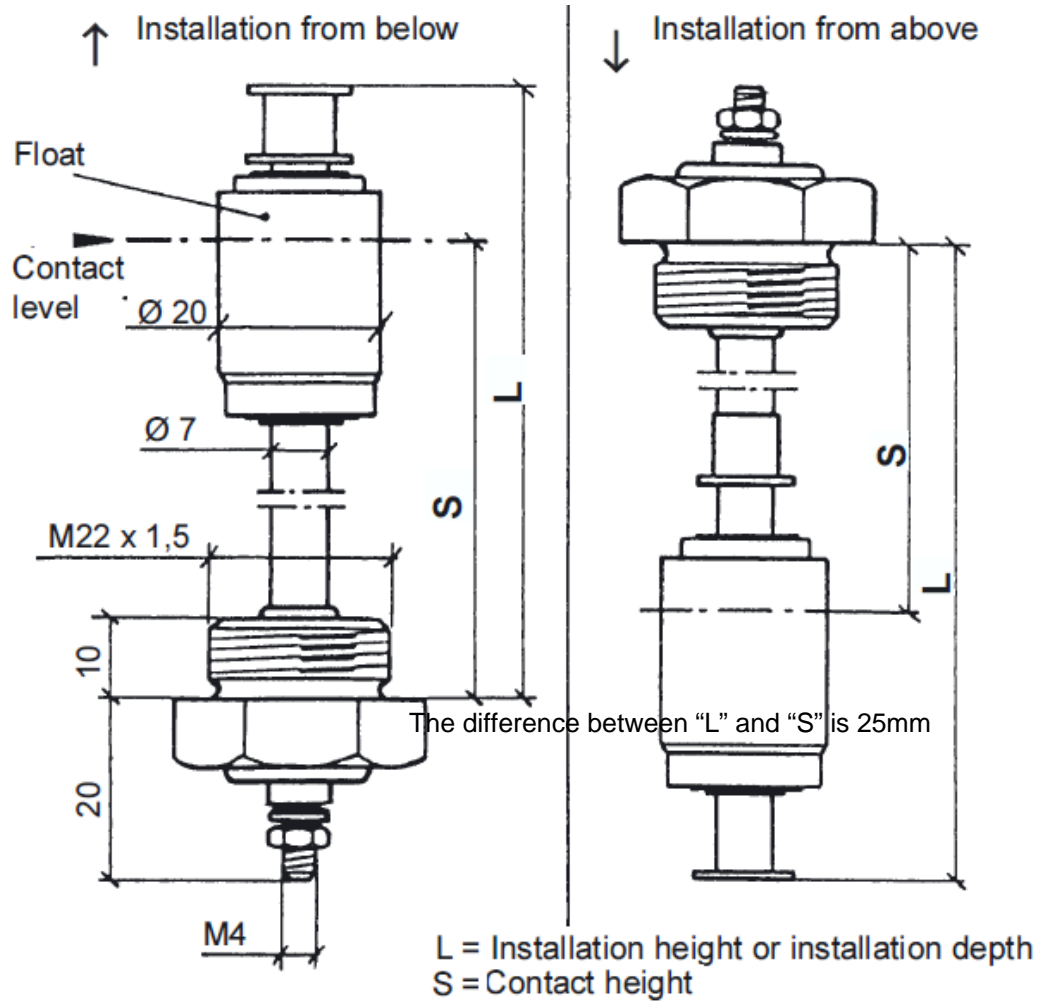

Oil Level Warning Switch

Part Number	Warning Contact		Stop Above	Stop Below	Cable Length
	hw	hw min	Ao	Au	
395024004005	35 $+1 -2$	6 $+2 -1$	37 -1	32 ± 1	1500
395024004008	29 ± 4.5	0 $+1 -2$	34 -2	20 ± 2	920

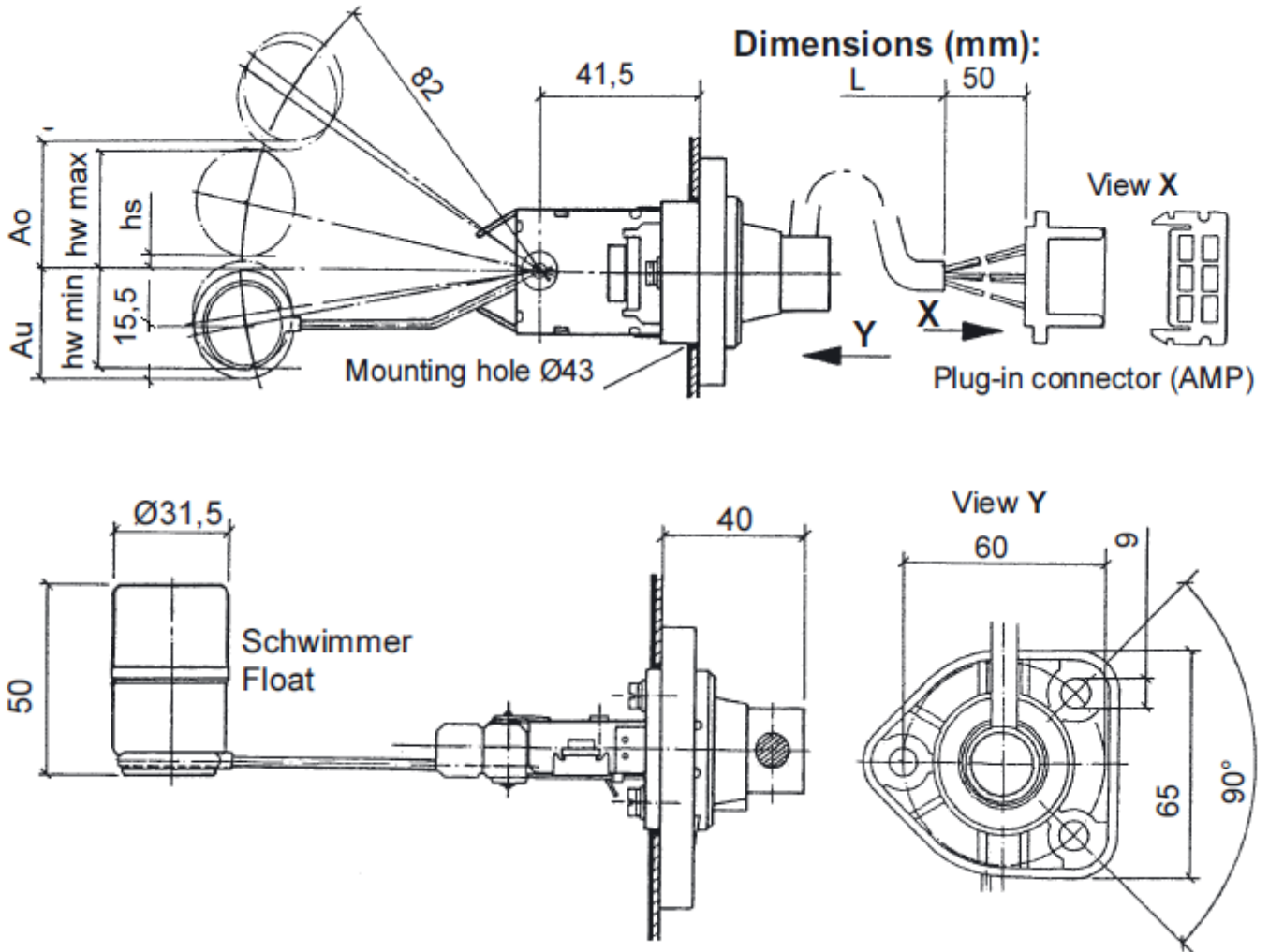

Technical Data

Plug configuration

- 1 Warning contact max. (green)
- 2 Masse / Ground (brown-white)
- 3 not connected
- 4 Warning contact min (yellow)
- 5 Contact-consumer (white)
- 6 Ground (brown-blue)

insulated return
 Rated voltage: 6V to 24V
 Switching load: 3W max., noninductive
 Contacting mode: slow-acting,
 NOC = with contacts normally open
 Operating temperature: -25°C to $+110^{\circ}\text{C}$
 Storage temperature: -30°C to $+110^{\circ}\text{C}$
 (up to $+120^{\circ}\text{C}$ for 1h max.)
 Installation form the side

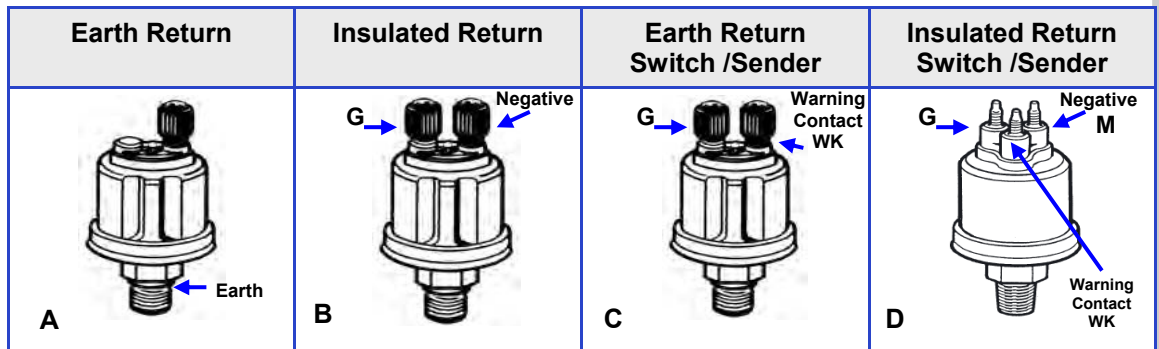

Pressure Sender - Oil / Air Single Station

Part Number	Range Bar (Psi)	Thread Size	Switch Point Bar (Psi)	Picture	Ohms Range
360081032025C	0 - 2 Bar (75)	1/8"-27NPTF	---	B	10 - 180
360081032011C	0 - 2 Bar (75)	M12x1.5	---	B	10 - 180

Pressure Sender - Oil / Air Single Station

Part Number	Range Bar (Psi)	Thread Size	Switch Point Bar (Psi)	Picture	Ohms Range
360.001	0 - 5 Bar (75)	1/8"-27NPTF	---	A	10 - 180
360.004	0 - 5 Bar (75)	1/4"-18NPTF	---	A	10 - 180
360.016	0 - 5 Bar (75)	1/8"-28BSP	---	A	10 - 180
360081032001C	0 - 5 Bar (75)	1/8"-27NPTF	---	B	10 - 180
360081032002C	0 - 5 Bar (75)	M10x1	---	B	10 - 180
360081030001K	0 - 5 Bar (75)	M10x1	0.25 Bar (3.5)	C	10 - 180
360081030002K	0 - 5 Bar (75)	M10x1	0.5 Bar (7)	C	10 - 180
360081030028K	0 - 5 Bar (75)	M14x1.5	0.5 Bar (7)	C	10 - 180
360081030049K	0 - 5 Bar (75)	1/8"-27NPTF	0.5 Bar (7)	C	10 - 180
360081030014C	0 - 5 Bar (75)	M10x1	0.6 bar (8.5)	C	10 - 180
360081030010C	0 - 5 Bar (75)	1/8"-27NPTF	1.4 Bar (11.5)	C	10 - 180
360081039002C	0 - 5 Bar (75)	1/8"-27NPTF	11.5 Psi	D	10 - 180
360081039004C	0 - 80 Psi	1/8"-27NPTF	10 Psi	D	10 - 180

Pressure Sender - Oil / Air Dual Station

Part Number	Range Bar (Psi)	Thread Size	Switch Point Bar (Psi)	Picture	Ohms Range
362081001001K	0 - 5 Bar (75)	1/8"-27NPTF	---	B	5 - 90
362081001002K	0 - 10 Bar (150)	1/8"-27NPTF	---	B	5 - 90
362081003002K	0 - 10 Bar (150)	1/8"-27NPTF	---	A	5 - 90
362081002001K	0 - 25 Bar (350)	1/8"-27NPTF	---	B	5 - 90
362081004001C	0 - 25 Bar (350)	1/8"-27NPTF	---	A	5 - 90

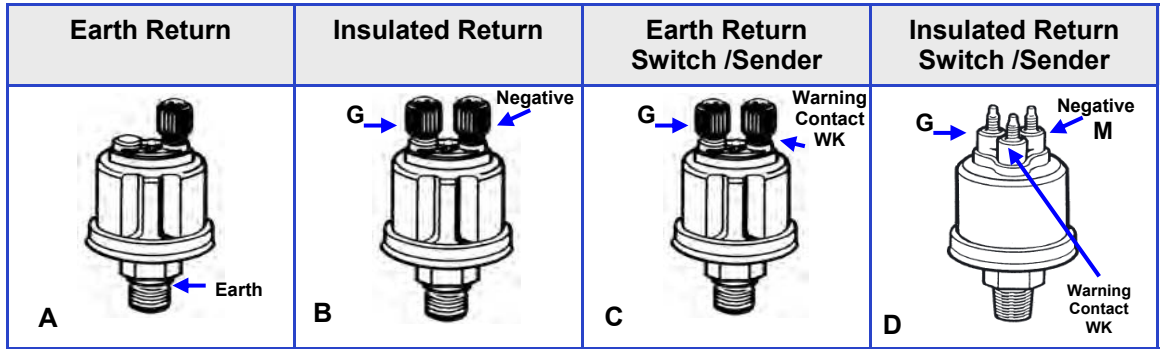

Pressure Sender/Switch - Oil / Air Single Station

Part Number	Range Bar (Psi)	Thread Size	Switch Point Bar (Psi)	Picture	Ohms Range
360081030009K	0 - 10 Bar (150)	M10x1	0.5 Bar (7)	C	10 - 184
360081030022C	0 - 10 Bar (150)	M12x1.5	0.5 Bar (7)	C	10 - 184
360081030052C	0 - 10 Bar (150)	1/8"-27NPTF	0.5 Bar (7)	C	10 - 184
360081030039C	0 - 10 Bar (150)	M10x1	0.75 Bar (10.7)	C	10 - 184
360081030015C	0 - 10 Bar (150)	1/8"-27NPTF	0.8 Bar (11.5)	C	10 - 184
360081030017C	0 - 10 Bar (150)	M10x1	0.9 Bar (12)	C	10 - 184
360081039003	0 - 10 Bar (150)	1/8"-27NPTF	0.8 Bar (11.5)	D	10 - 184

Pressure Sender - Oil / Air Single Station

360081039003	0 - 25 Bar (400)	1/8"-27NPTF	-----	B	10 - 184
--------------	------------------	-------------	-------	---	----------

1-pole Common Ground
Screw M4 x 5



Insulated Return
Screw M4 x 5
(2x)

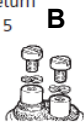

Insulated Return
6.3 x 0.8 mm
riveted



Pressure Switches - Heavy Duty

Part Number	Switch Point Bar (Psi)	Thread Size	Terminals	Picture	Switch Contact
230112005006	0.5 Bar (7) Fixed	1/8"-27NPTF	Screw x 2 Insulated Return	B	N/C Falling Pressure
230.044	0.5 Bar (7) Fixed	1/8"-27NPTF	Screw x 2 Insulated Return	B	N/C Falling Pressure
230213002004	4.5 Bar (64) Fixed	M10 x 1	Screw x 2 Insulated Return	B	N/C Falling Pressure
230213002001	7.5 Bar (64) Fixed	1/8"-27NPTF	Screw x 2 Insulated Return	B	N/C Falling Pressure
230.041	0.7 Bar (10) Fixed	1/8"-27NPTF	Screw x 1 Earth Return	A	N/C Falling Pressure
230.701	1.05 Bar (15) Fixed	1/8"-27NPTF	Screw x 2 Insulated Return	B	N/C Falling Pressure
230.050	0.5 Bar (7) Fixed	1/8"-27NPTF	Screw x 2 Insulated Return	B	N/O Falling Pressure
230.990	7 - 25 Psi Adjustable	1/8"-27NPTF	Screw x 2 Insulated Return	C	N/C Falling Pressure
230.993	15 - 150 Psi Adjustable	1/8"-27NPTF	Screw x 2 Insulated Return	C	N/C Falling Pressure

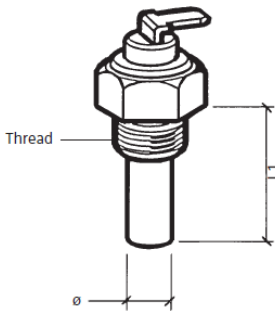

1-pole Common Ground
6.3 x 0.8 mm



1-pole Common Ground

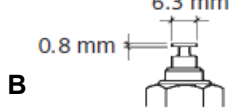

1-pole Common Ground
Hex nut

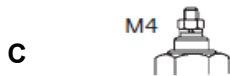

Insulated Return
6.3 x 0.8 mm (2x)

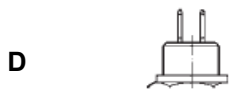

Blade connector
WK: 4.8 x 0.8 mm
G: 6.3 x 0.8 mm
WK = Warning Contact
G = Sensor

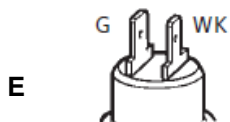

2 blade connectors arranged in the form of letter "T"
6.3 x 0.8 mm
WK = Warning Contact
G = Sensor

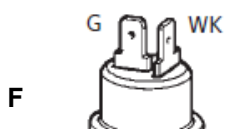

Temp Senders		40 -120 Deg C			
Part Number	Switch Point	Thread Size	Term	Body Length	°C ▶ Ohms
323801001006K	-----	M14x1.5	A	29 mm	90 ▶ 51.2 ± 5.3
323801001040N	-----	M16x1.5	A	29 mm	90 ▶ 51.2 ± 5.3
323801001022K	-----	M18x1.5	A	29 mm	90 ▶ 51.2 ± 5.3
323801001010K	-----	1/2-14 NPTF	A	29 mm	90 ▶ 51.2 ± 5.3
323801001009N	-----	1/4-18 NPTF	A	29 mm	90 ▶ 51.2 ± 5.3
323801001007N	-----	3/8-18 NPTF	A	29 mm	90 ▶ 51.2 ± 5.3
323801001008N	-----	5/8-18 UNF-3A	A	29 mm	90 ▶ 51.2 ± 5.3
323805001001K	-----	M14x1.5	D	29 mm	90 ▶ 51.2 ± 5.3
323805001015N	-----	M18x1.5	D	29 mm	90 ▶ 51.2 ± 5.3
323805001004K	-----	1/2-14 NPTF	D	29 mm	90 ▶ 51.2 ± 5.3
323805001007N	-----	1/4-18 NPTF	D	29 mm	90 ▶ 51.2 ± 5.3
323805001005N	-----	3/8-18 NPTF	D	29 mm	90 ▶ 51.2 ± 5.3
323805001002C	-----	5/8-18 UNF-3A	D	29 mm	90 ▶ 51.2 ± 5.3
325805003001C	-----	1/4-18 NPTF	D	29 mm	90 ▶ 36.5 ± 2.7

Temp Senders & Switch		40 -120 Deg C			
Part Number	Switch Point	Thread Size	Term	Body Length	°C ▶ Ohms
323803001004D	90±3°C	M14x1.5	E	40 mm	90 ▶ 51.2 ± 5.3
323803001006D	96±3°C	M14x1.5	E	40 mm	90 ▶ 51.2 ± 5.3
323803001008D	110±3°C	M14x1.5	E	40 mm	90 ▶ 51.2 ± 5.3
323803001011D	95±3°C	5/8-18 NF-3	E	40 mm	90 ▶ 51.2 ± 5.3
323803001002D	98±3°C	5/8-18 NF-3	E	40 mm	90 ▶ 51.2 ± 5.3
323803001012D	100±3°C	5/8-18 NF-3	E	40 mm	90 ▶ 51.2 ± 5.3
323803001019D	95±3°C	1/2-14 NPTF	E	40 mm	90 ▶ 51.2 ± 5.3
323803001013D	106±3°C	M14x1.5	E	40 mm	90 ▶ 51.2 ± 5.3
323803004002D	105±3°C	M14x1.5	F	40 mm	90 ▶ 51.2 ± 5.3

Temp Senders		50 -150 Deg C			
Part Number	Switch Point	Thread Size	Term	Body Length	°C ▶ Ohms
323801010001D	-----	M10x1.5	D	29 mm	120 ▶ 36.5 ± 2.7
323805003001N	-----	M14x1.5	D	29 mm	90 ▶ 36.5 ± 2.7
323805003002N	-----	1/4-18 NPTF	D	29 mm	90 ▶ 36.5 ± 2.7

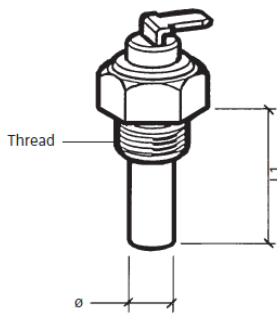

1-pole Common Ground
6.3 x 0.8 mm



1-pole Common Ground

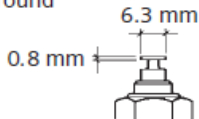

B

1-pole Common Ground
Hex nut



Connector pin

Ø 4 mm



Temp Switch 3 Watts Normally Open Contact - Break 5° below Sw point

Part Number	Switch Point	Thread Size	Term	Body Length L	Max Temp	Ø mm
232011017148D	35±3°C	M14x1.5	A	29 mm	120	9.7
232011017087D	40±3°C	M14x1.5	D	29 mm	120	10
232011017038D	55±3°C	M14x1.5	A	29 mm	120	10
232011017017D	85±3°C	M14x1.5	A	29 mm	120	10
232011017016D	95±3°C	M14x1.5	A	29 mm	150	10
232011017080D	97±3°C	M14x1.5	A	29 mm	120	10
232011017099D	98±3°C	5/8-18 UNF-2A	A	29 mm	120	10
232011017034D	100±3°C	M14x1.5	A	29 mm	160	10
232011017131D	103±3°C	1/2-14 NPTF	A	29 mm	160	10
232011017010D	110±3°C	M14x1.5	A	29 mm	160	10
232011017032D	120±3°C	M14x1.5	A	29 mm	130	10
232011017103D	130±3°C	M14x1.5	A	29 mm	150	10
232011017004D	140±10°C	M14x1.5	A	29 mm	150	10
232011005027D	150±5°C	M10x1.5	B	38.5 mm	200	6.9
232011005004D	170±5°C	M10x1.5	C	38.5 mm	220	6.9
232011005030D	185±5°C	M10x1.5	C	38.5 mm	230	6.9
232011019003D	195±10°C	M10x1.5	C	38.5 mm	250	6.9

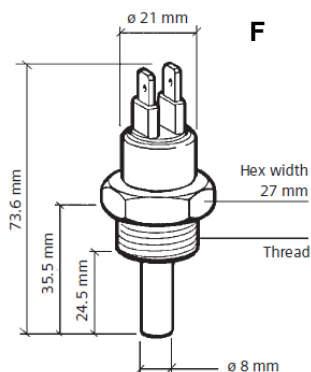
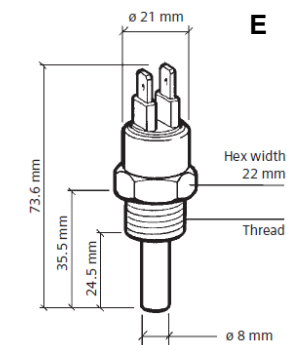

Temp Switch 100 Watts Normally Open Contact - Break 5° below Sw point

Part Number	Switch Point	Thread Size	Term	Body Length L	Max Temp	Ø mm
X10232001001	64±3°C	M14x1.5	E	35.5 mm	110	8
X10232001002	82±3°C	M18x1.5	E	35.5 mm	110	8
X10232001003	86±3°C	M18x1.5	E	35.5 mm	110	8
X10232001004	92±3°C	M18x1.5	E	35.5 mm	110	8
X10232001005	96±3°C	M18x1.5	E	35.5 mm	110	8
X10232001006	96±3°C	1/2-14 NPTF	E	43.5 mm	110	8
X10232001007	96±3°C	M14x1.5	E	35.5 mm	110	8
X10232001008	96±3°C	M22x1.5	F	35.5 mm	110	8
X10232001009	100±3°C	M18x1.5	E	35.5 mm	110	8
X10232001010	105±3°C	M18x1.5	E	35.5 mm	160	8

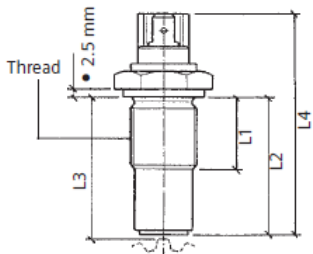
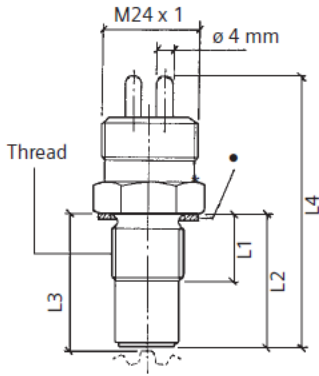

Blade connector 6.3 x 0.8 mm (2x)



Inductive

Part Number	Pic	Thread Size	L1 mm	L2 mm	L3 mm	L4 mm
340.007	B	M18x1.5 mm			25	
340.008	B	M18 x 1,5			44	
340.009	B	M18 x 1,5			84	
340804007013C	B	M18 x 1,5	27	34	35.1 ± 0.1	62
340804007004C	B	3/4-16 UNF-2A	27.5	28.5	29.6 ± 0.1	70
340804007011C	B	M18 x 1,5	33	34	35.1 ± 0.1	70
340804007019C	B	M18 x 1,5	18.2	70.7	71.8 ± 0.1	79.7
340804005015C	A	M18x1,5	18	99.1	101.15–100.55	135.6

Proximity Switch & Hall Effect *Square wave output*

Part Number	Voltage	Thread Size	Pic	Type	Imp/ Rev	Plug Kit
K46020	12/24V	M22x1.5	1	H/E	8	K72221
K46021	12/24V	7/8"-18UNF	1	H/E	8	K72221
K70450	12V	M22x1.5 L/ H Female	2	H/E	8	K72222
K70451	12V	7/8"18UNF	2	H/E	8	K72222
340808001004G		7/8" – 18 NS-2A left hand	3	Gen	4	

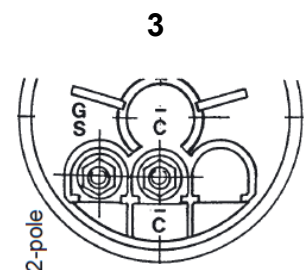
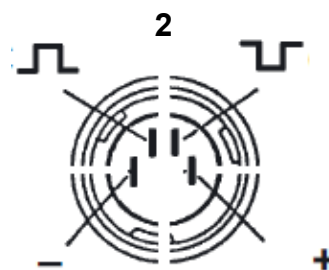
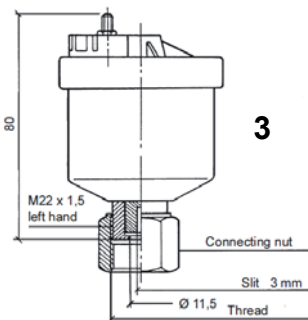
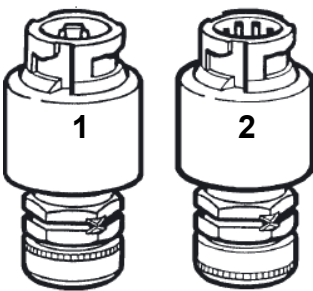



Lever Fuel Sensor - with low fuel alarm

Part Number	Ohms Range	Adjustable	Pitch Ø
A2C59510165	Empty = 3 - Full = 180	145 - 400 mm	54 mm
A2C59510166	Empty = 240 - Full = 33	145 - 400 mm	54 mm
A2C59510167	Empty = 5 - Full = 90	145 - 400 mm	54 mm

Lever Fuel Sensor - without low fuel alarm

Part Number	Adjustable 145—400 mm	Ohms Range	Pitch Ø
A2C59510171	Empty = 3 - Full = 180	145 - 400 mm	54 mm
A2C59510172	Empty = 240 - Full = 33	145 - 400 mm	54 mm
A2C59510173	Empty = 5 - Full = 90	145 - 400 mm	54 mm

An economical and practical solution for fuel monitoring for tank depths from 140mm to 400mm

Engineered with a redundant dual wiper system, our unique VDO 'quiet arm' and thick film technology, this new VDO fuel sender leads the field in reliability and durability. In fact, this family of senders has the ability to withstand over one million swing arm cycles without failure. ALAS I senders feature our unique slotted SAE five-hole flange mount, an industry first that gives you the utmost in versatility for sender mounting positions. Three resistance values are available, 10-180 ohm, 240-33 ohm & 90-0 ohm. ALAS I senders are available with an optional low fuel warning contact circuit found in no other universal

1. Available with low fuel warning contact.
2. Redundant ground connection.
3. Unique SAE 5-hole slotted mounting plate allows for positioning sender for left or right hand applications.
4. Stainless steel float arm and pivot adjusts from 140mm to 400mm.
5. "No sink" solid float.
6. VDO thick film element with 39-step resolution.
7. Redundant dual wiper system.
8. 'Quiet arm' minimizes float movement.

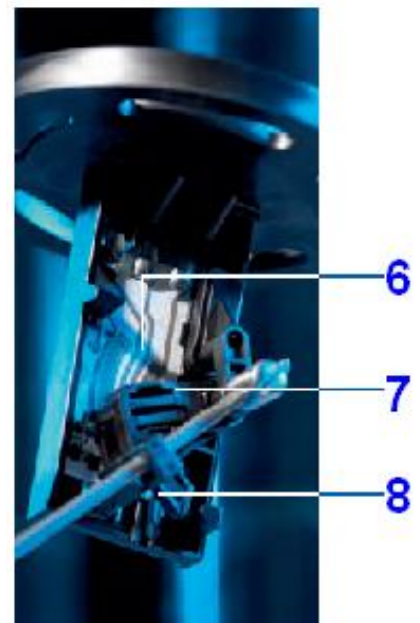

Fuel Senders with Suction / Return Tubes

VDO is first to market with the only adjustable fuel sender featuring interchangeable suction / return tubes, plus optional low fuel warning contact.

Just pick the length and diameter of the suction / return tubes based on your gas or diesel application, set the float length and you're ready for installation.

If you have several tank configurations, inventory is minimized with our 'one size fits all' design, without compromising the durability or integrity of the sender.

These units are fully adjustable from 140mm to 400mm.

Engineered with a redundant dual wiper system, the unique VDO 'quiet arm' and thick film technology leads the field in reliability and durability.

In fact, this family of senders has the ability to withstand over one million swing arm cycles without failure.

VDO senders feature our unique slotted SAE 5-hole flange mount, an industry first that gives you the utmost in versatility for sender mounting positions.

Three resistance values are available, 10-180 Ohms, 240-33 Ohms & 5 - 90Ohms.

The senders are available with an optional low fuel warning contact circuit that is not offered in other universal type senders.

Upon request, we can supply senders fully assembled to your specifications.

Each suction / return tube has 360° of positioning capability within the flange to meet your specific application.

Suction / return tubes available in four different diameters (6.5mm, 8mm, 10 and 12mm), accommodating tank depths up to 400mm.

Where return tubes are not required, a port plug is available.



- Composite construction.
- Available with or without low fuel warning contact.
- Available factory set to customer specifications.
- Available in 10 - 180 Ohm, 240 - 33 Ohm, 5 - 90 Ohm range.

1. Steel reinforced mounting hardware.
2. Available with low fuel warning contact.
3. Redundant ground connection.
4. Unique SAE 5-hole slotted mounting plate allows for positioning sender for left or right hand applications.
5. Stainless steel float arm and pivot adjusts from 140mm to 400mm.
6. 'No sink' solid float.
7. VDO thick film element with 39-step resolution.
8. Redundant dual wiper system.
9. 'Quiet arm' minimizes float movement.

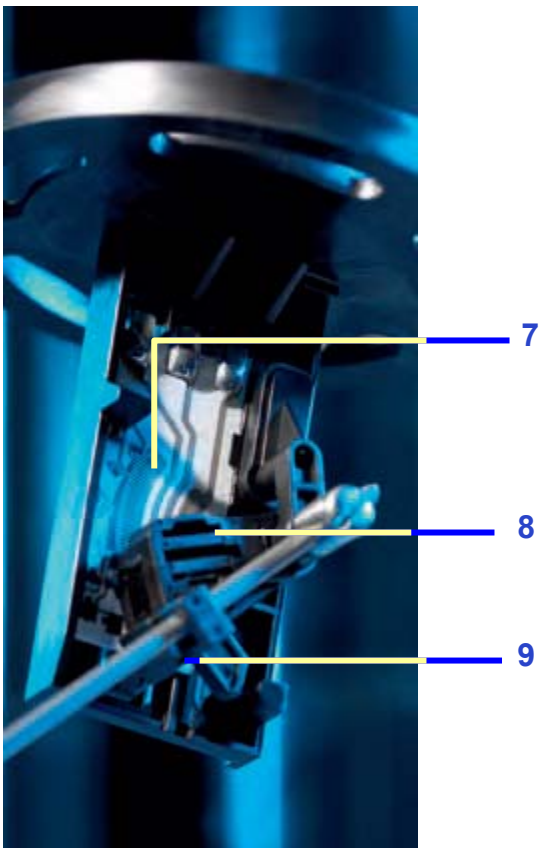
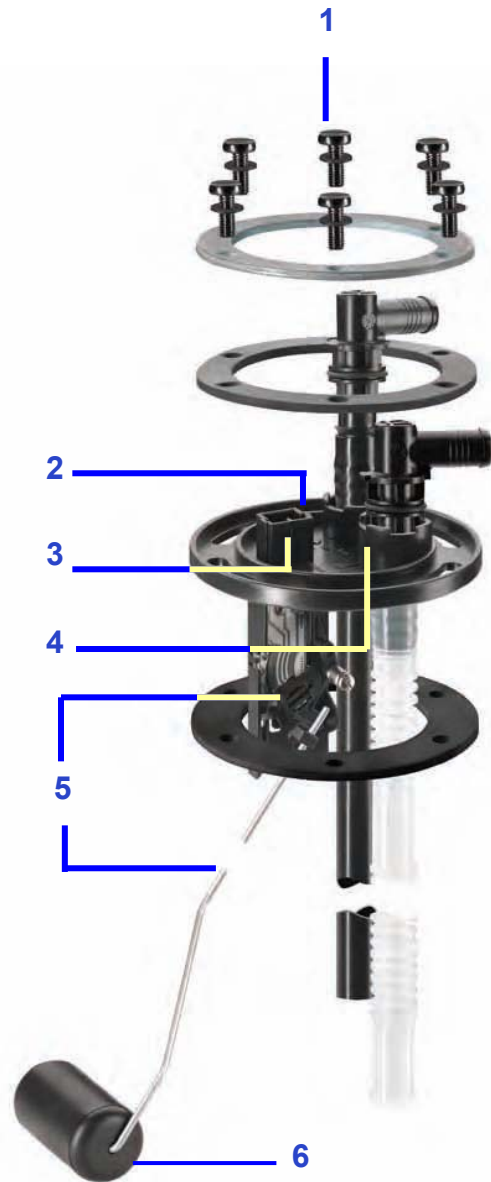



Adjustable Lever Arm Sensor 140 - 400mm (Insulated return)

Part Number Qty 1	Part Number Qty 10	Description	Ohms Range
226.946	A2C59510946	Adjustable Lever Arm Sensor Flange for use with feed and return pipe.	Empty = 3 - Full = 180
226.973	A2C59510973	Adjustable Lever Arm Sensor Flange for use with feed and return pipe.	Empty = 240- Full = 33
226.975	A2C59510975	Adjustable Lever Arm Sensor Flange for use with feed and return pipe.	Empty = 5 - Full = 90

Suction & Return Tubes

Part Number Qty 1	Part Number Qty 10	Suction Tube Inner Ø	Part Number Qty 1	Part Number Qty 10	Return Tube Inner Ø
226.955	A2C59510955	6.5 mm	226.956	A2C59510956	6.5 mm
226.953	A2C59510953	8.0 mm	226.954	A2C59510954	8.0 mm
226.951	A2C59510951	10.0 mm	226.952	A2C59510952	10.0 mm
226.949	A2C59510949	12.0 mm	226.950	A2C59510950	12.0 mm

Accessories

Part Number Qty 1	Part Number Qty 10	Description
226.965	A2C59510965	Blind Plug (if one or both tubes are not required)
A2C53326385		Installation kit (Screws, Gasket, Flange, Washers)
226.479	A2C59511479	Lever Arm Sub-Assembly



Fitting Instructions

Description	Page #
Sumlog	46
Tachourmeter	47
Tachometer	48
Synchroniser	49
Rudder Angle Gauge	50
Fuel Level Gauge & Sender Arm / Reed Switch Type	51
Fuel Level Gauge & Sender Tubular Type	52
Fresh Water Level Gauge & Sender Reed Switch Type	53
Waste/Grey Water Gauge & Sender 4 - 20 mA Capacitance	54
Temp Gauge & Sender 40 - 120C / 50 - 150C	55
Pressure Gauge & Sender 5 Bar - 10 Bar	56
Pressure Gauge & Sender 25 Bar - 30 Bar	57
Ammeter	58
Clock	59
Hourmeter	59
Voltage Dropping Resistors from 24V to 12V (90° Deflection dials, only)	60
Alarm Switch Temp - Pressure - Fuel	61

Sumlog electrical diagram

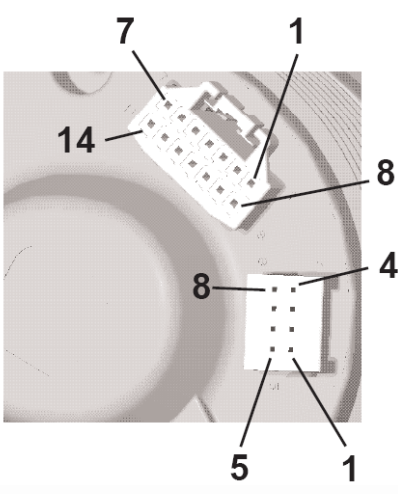
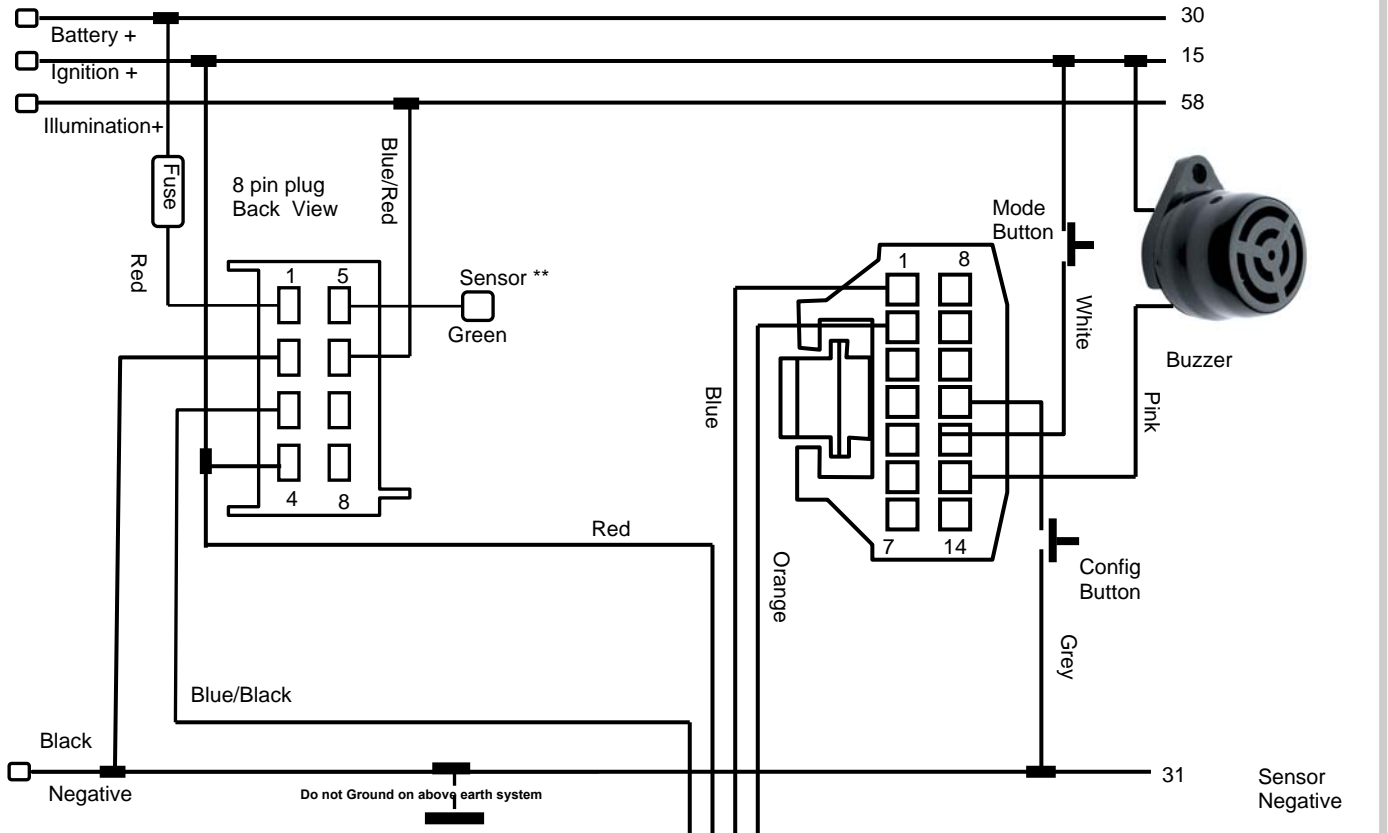

8 way connector Kit
p/n A2C59510850



Connector Kit 14-pin -
p/n A2C59510851



A2C59513503
Sensor to Sumlog, Loom

NMEA0183 Sensor *



Through-Hull Kit



Transom Kit

See page 72 for calibration procedures
 Note: * Set input calibration to NMEA0183 (No pulse calibration needed)
 ** Terminal 5 used only for Hall Effect Output Sensors

Tachourmeter electrical diagram

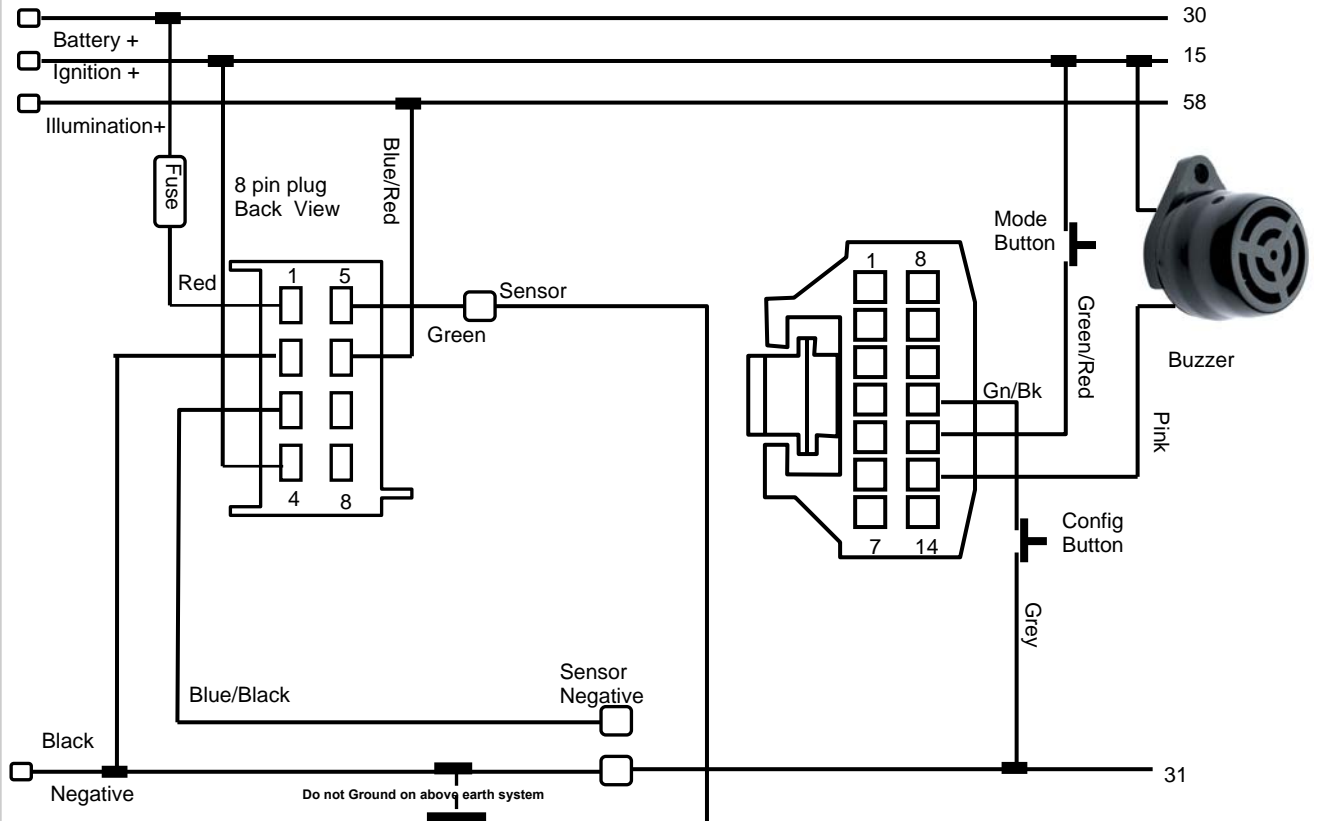

8 way connector Kit
p/n A2C59510850

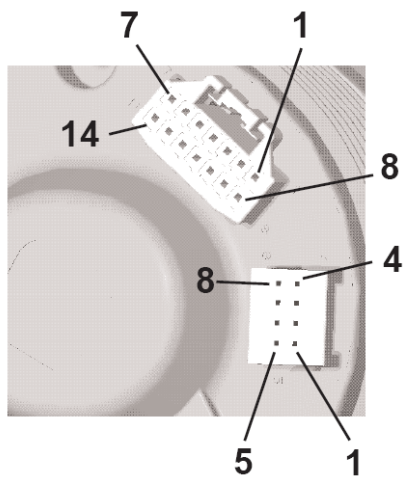

Connector Kit 14-pin -
p/n A2C59510851

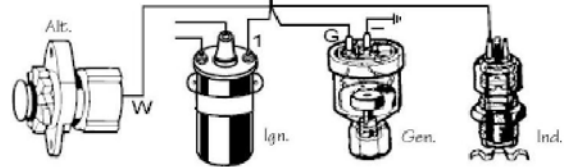

See page 76 for calibration procedures

Tachometer electrical diagram

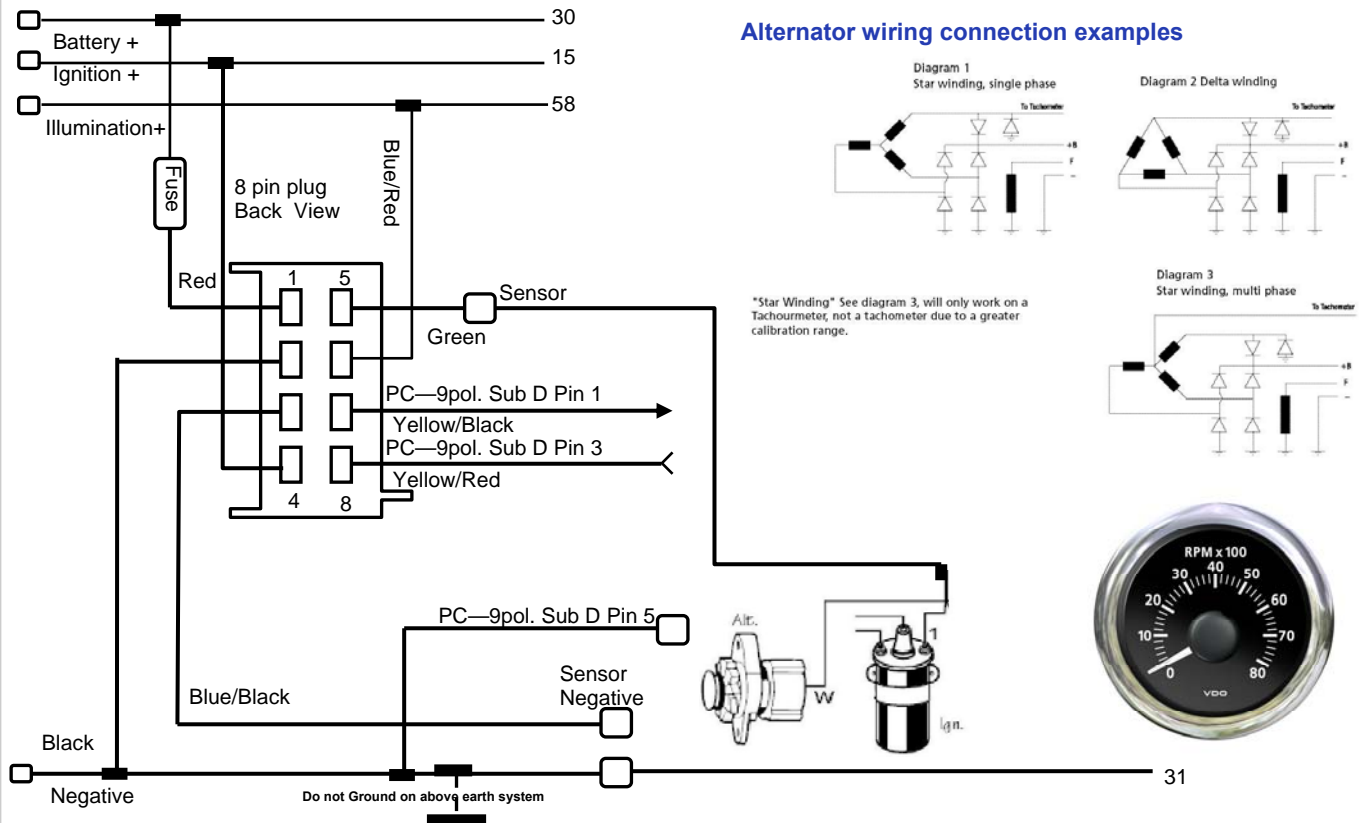

CALIBRATION

No. Cyl 's	Str	No. Cyl 's	Str	Imp/Rev	Switch 1	Switch 2	Switch 3
				XXX	0	0	0
2	4			1	1	0	0
4	4	2	2	2	0	1	0
6	4			3	1	1	0
8	4	4	2	4	0	0	1
				5	1	0	1
12	4	6	2	6	0	1	1
				8	1	1	1

Negative side of ignition coil on an electronic pointless ignition system.

1. Switch **On** Battery power T. 30 (8-pin - Pin1)
2. Ignition power **Off** T. 15 (8-pin - Pin4)
3. Set impulse number according to chart below.

Ensure that switch position "1" is pointing toward the centre of instrument.

Alternator signal

If the alternator is directly driven, by the engine shaft

Eg: Marine Outboard motors,

the tacho can be calibrated by knowing the imp/revolution of the alternator, using a single phase connection (not a Star multi phase).

The calibration can be processed by selecting the number of imp/rev according to the pole-pairs of the alternator.

For the standard alternator running off a pulley linked to the crankshaft pulley, the tachometer can only be calibrated by a VDO Service Agent using a special software.

The alternative is to use a Tachourmeter where the calibration can be done via a configuration button without using the software.

Note: Tachometer will not operate off a Magneto signal.

Synchroniser Gauge Ø 85 mm

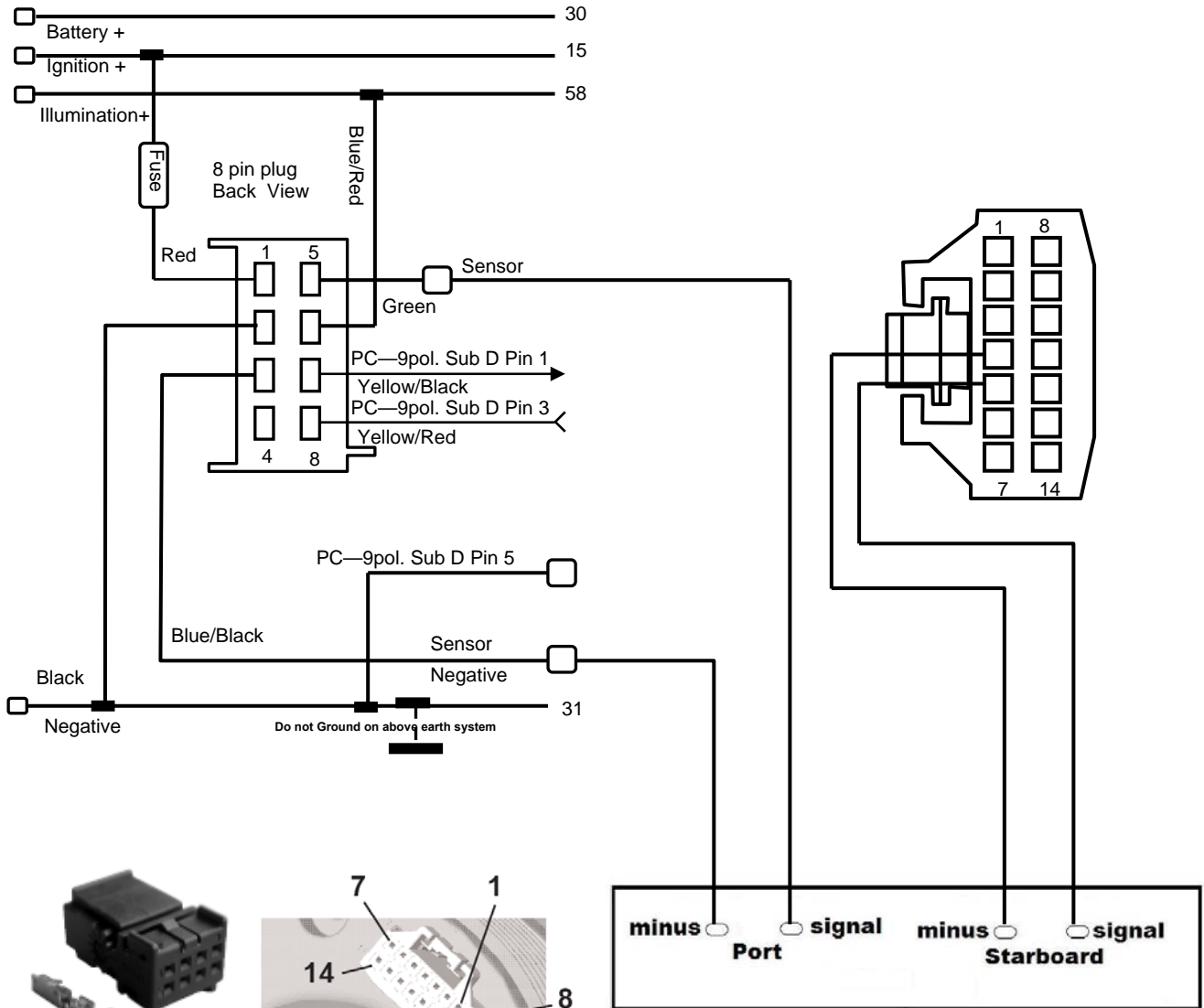

8 way connector Kit
p/n A2C59510850

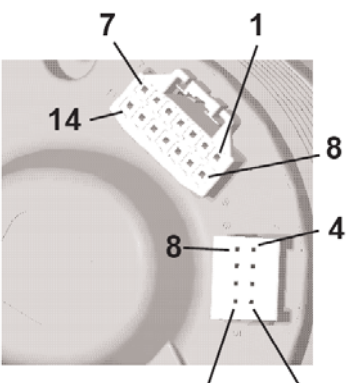

Connector Kit 14-pin -
p/n A2C59510851

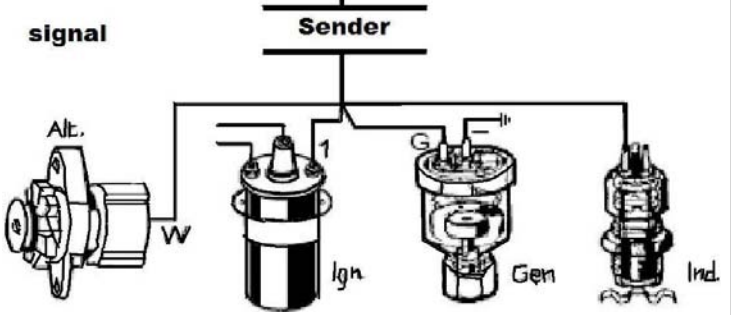

Rudder Angle



Rudder Angle Ø 52 mm & Ø 85 mm

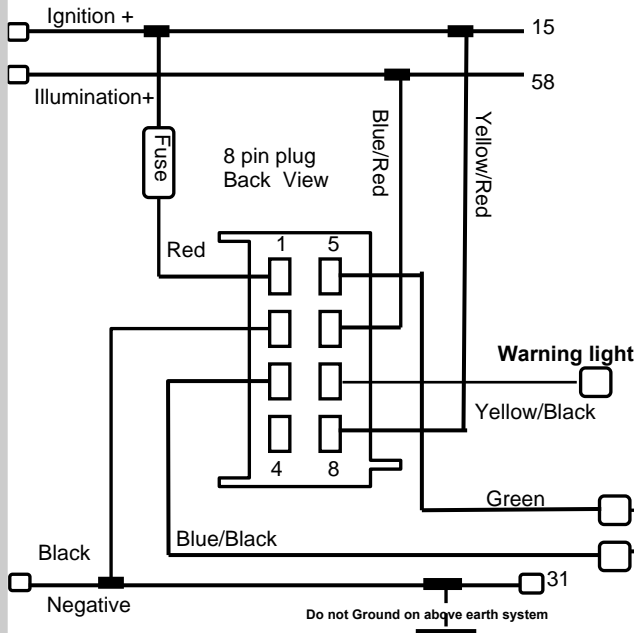

Note: For dual station installation, connect Green wire to second gauge

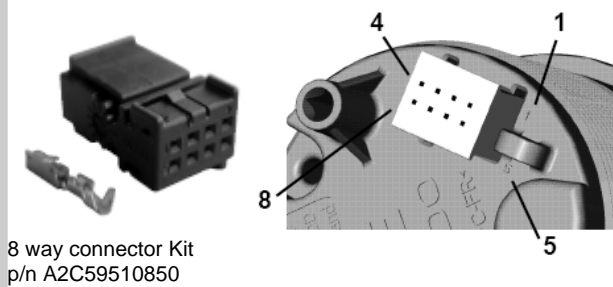

8 way connector Kit
p/n A2C59510850

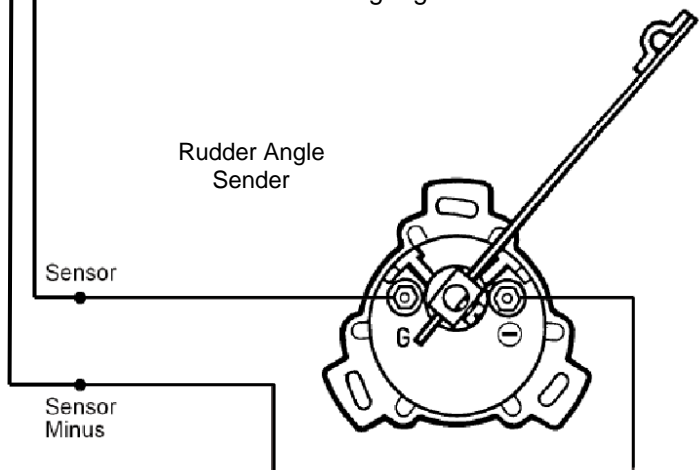

Rudder Angle sensor calibration

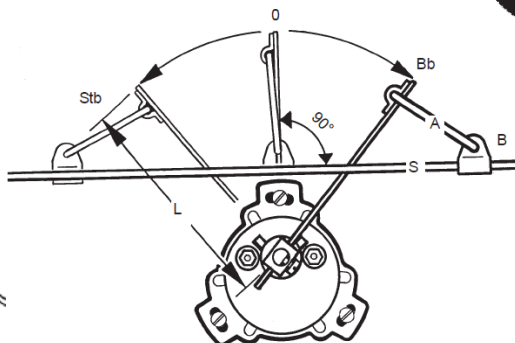
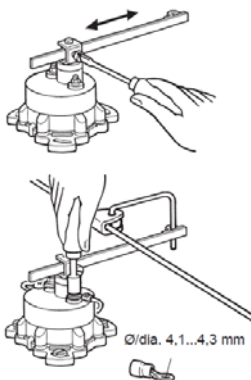

Bb

0

Stb

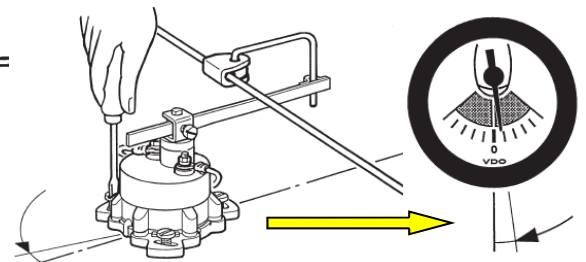

Fuel Gauge – Arm & Reed Switch Type Senders

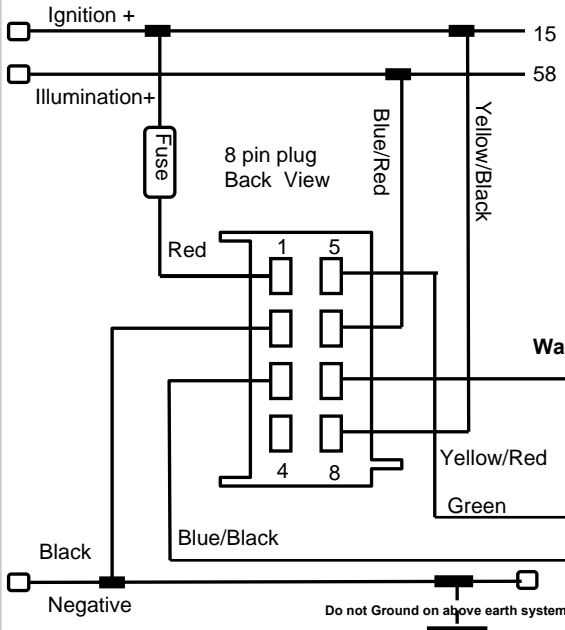

Version with Warning Contact

Arm type sender

Version without Warning Contact

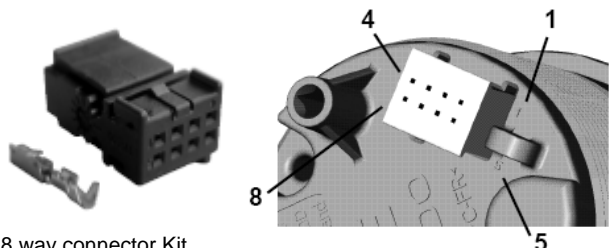

8 way connector Kit p/n A2C59510850

Reed Switch sender

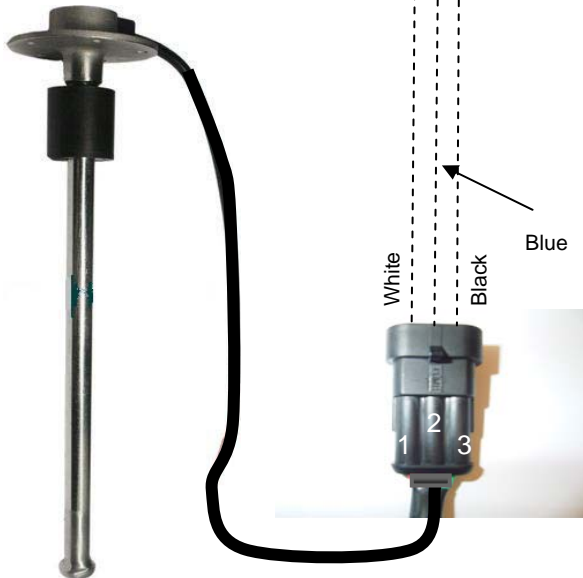

- Pin 1 - Wh - Low Fuel Warning
- Pin 2 - Bl - Output signal
- Pin 3 - Bk - Negative

0 to 1/1

Indication	0	1/4	1/2	3/4	1/1
Resistance (Ω)	3	45	85	138	180
Deflection ($^\circ \angle$)	0	17.2	41.2	73.8	88.8
Tolerance ($^\circ \angle$)	+ 3.6 - 3.6	\pm 3.6	\pm 3.6	\pm 3.6	+ 3.6 - 3.6

Fuel Gauge – Tubular Type Senders

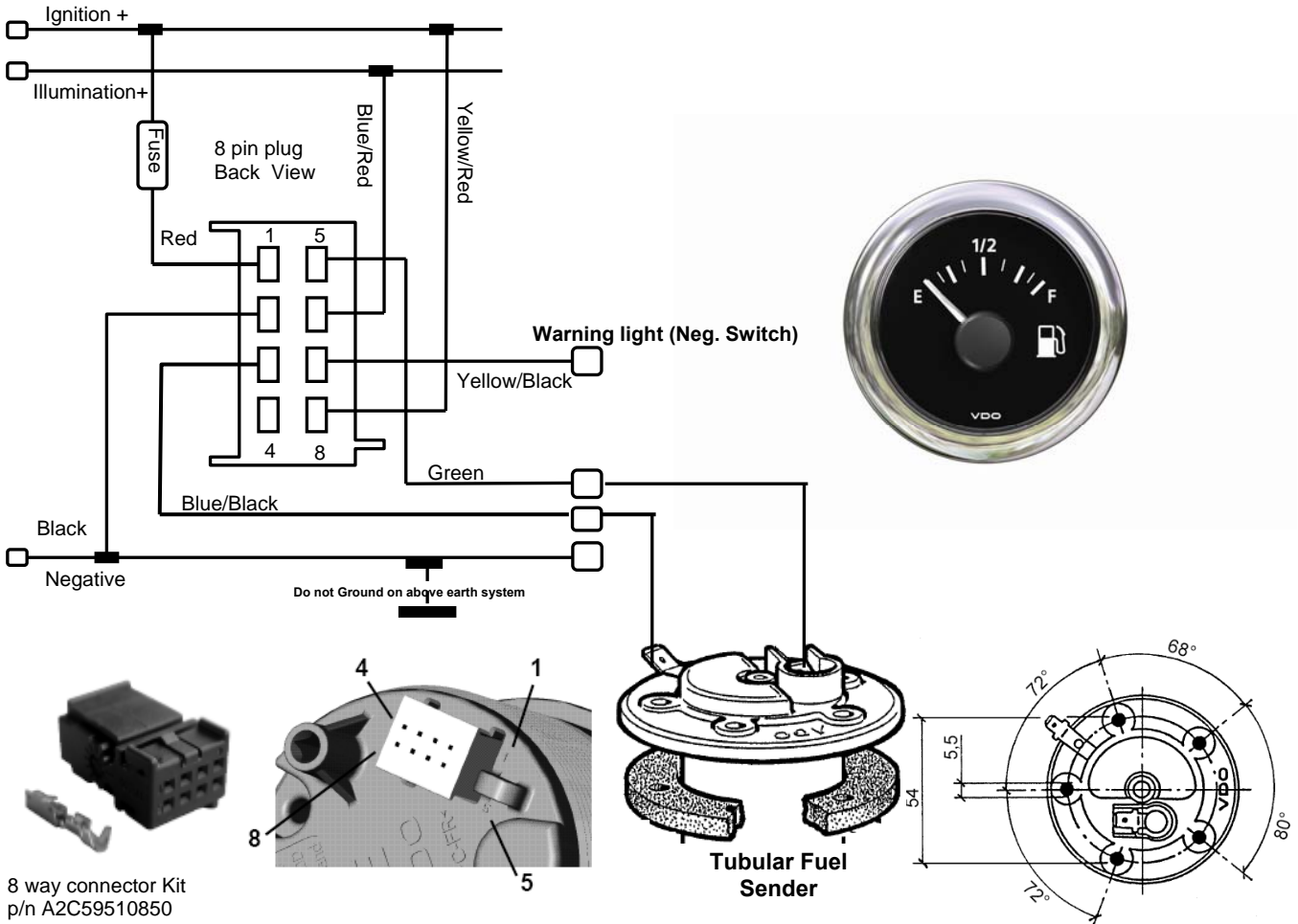

Sender Part No.	Length	Pitch Ø	Cut-out	Ohm Full	Ohms Empty
224011000015G	150mm	54mm	41mm	4.5	69
224011000016G	160mm	54mm	41mm	4.5	74
224011000017G	170mm	54mm	41mm	4.5	79.5
224011000018G	180mm	54mm	41mm	3	64
224011000019G	190mm	54mm	41mm	3	68
224011000020G	200mm	54mm	41mm	3	68
224011000021G	210mm	54mm	41mm	3	76
224011000022G	220mm	54mm	41mm	3	80
224011000023G	230mm	54mm	41mm	3	84
224011000024G	240mm	54mm	41mm	3	65.5
224011000025G	250mm	54mm	41mm	2.5	72
224011000026G	260mm	54mm	41mm	2.5	72
224011000027G	270mm	54mm	41mm	2.5	74.5
224011000028G	280mm	54mm	41mm	2.5	75.5
224011000029G	290mm	54mm	41mm	2.5	78
224011000030G	300mm	54mm	41mm	2.5	82.8

Sender Part No.	Length	Pitch Ø	Cut-out	Ohm Full	Ohms Empty
224011000031G	310mm	54mm	41mm	2.5	84
224011000032G	320mm	54mm	41mm	2.5	69.5
224011000033G	330mm	54mm	41mm	2.5	72
224011000034G	340mm	54mm	41mm	2.5	74
224011000035G	350mm	54mm	41mm	2.5	79.6
224011000036G	360mm	54mm	41mm	2.5	69
224011000037G	370mm	54mm	41mm	2.5	71
224011000038G	380mm	54mm	41mm	2.5	73
224011000039G	390mm	54mm	41mm	2.5	75
224011000040G	400mm	54mm	41mm	2.5	74.9
224011000045G	450mm	54mm	41mm	2.5	84.3
224011000050G	500mm	54mm	41mm	2.5	75.4
224011000055G	550mm	54mm	41mm	2.5	77.6
224011000060G	600mm	54mm	41mm	2.5	85.3
224011000065G	650mm	54mm	41mm	2.5	82.2
224011000070G	700mm	54mm	41mm	2	81.6
224011000075G	750mm	54mm	41mm	2	82
224011000080G	800mm	54mm	41mm	2	68.5

Fresh Water Gauge – Reed Switch Senders

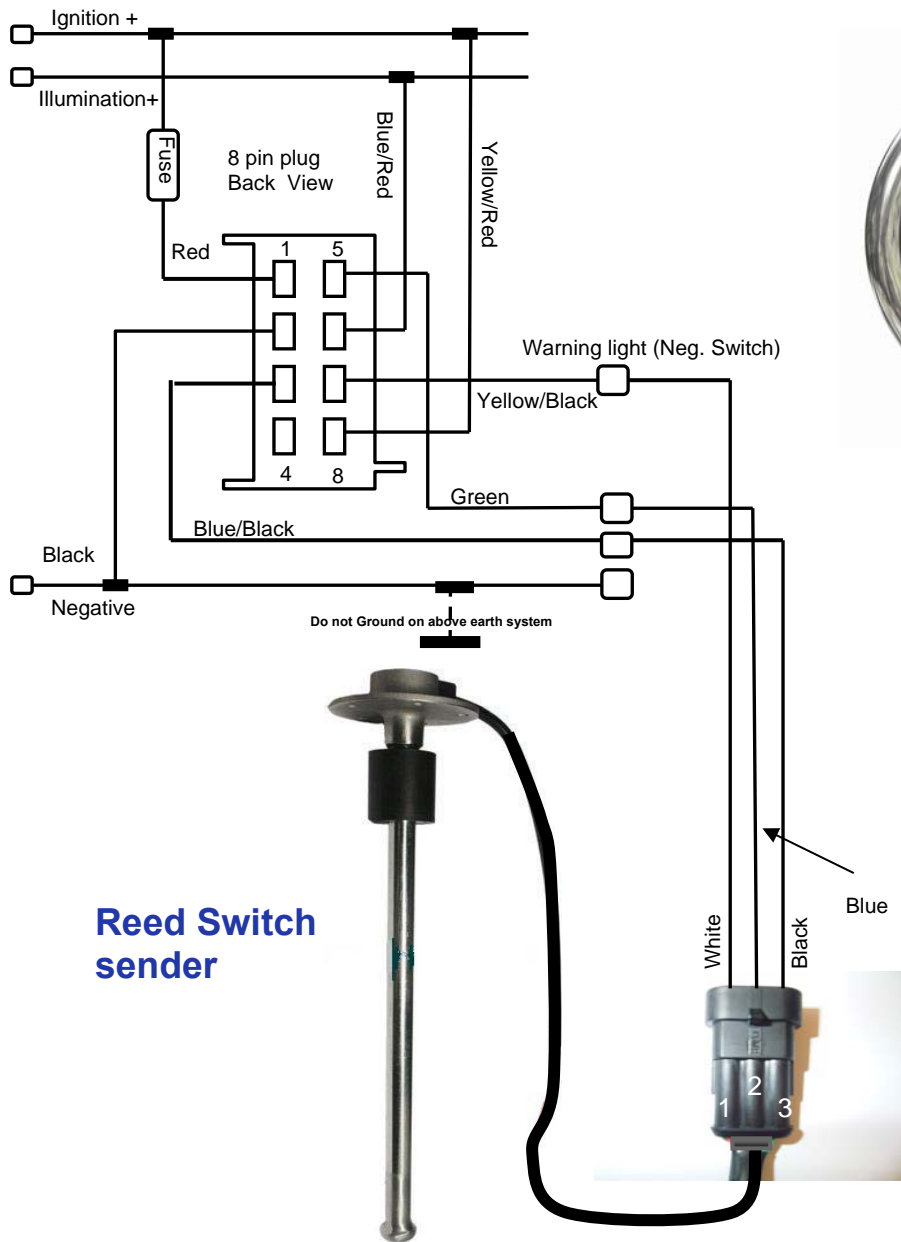

- Pin 1 - Wh - Low Water Warning
- Pin 2 - Bl - Output signal
- Pin 3 - Bk - Negative

Waste Water Gauge Connected to a 4 - 20 mA Sender

Dual Station: Two Gauges off one sensor, parallel the second gauge wires

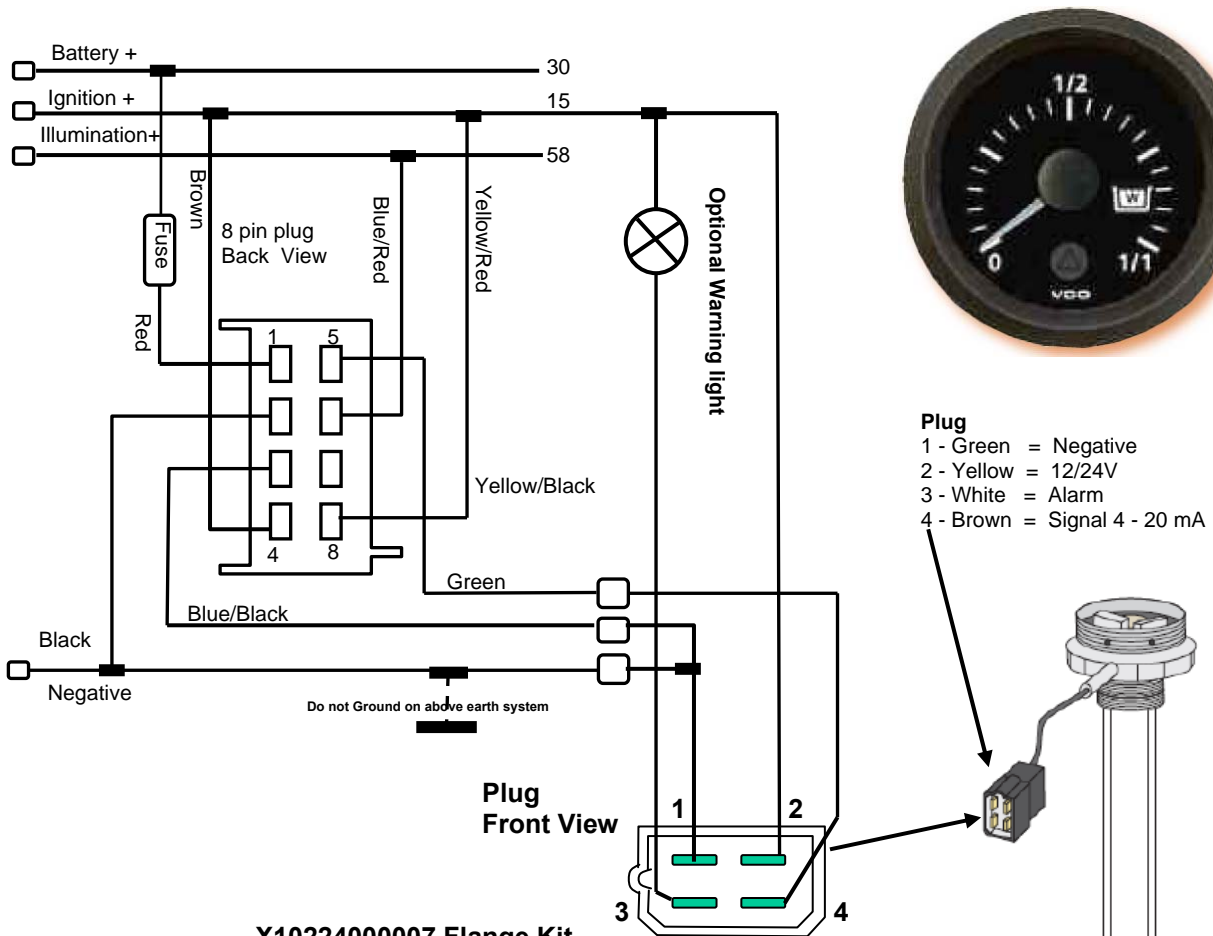

- Plug**
- 1 - Green = Negative
 - 2 - Yellow = 12/24V
 - 3 - White = Alarm
 - 4 - Brown = Signal 4 - 20 mA

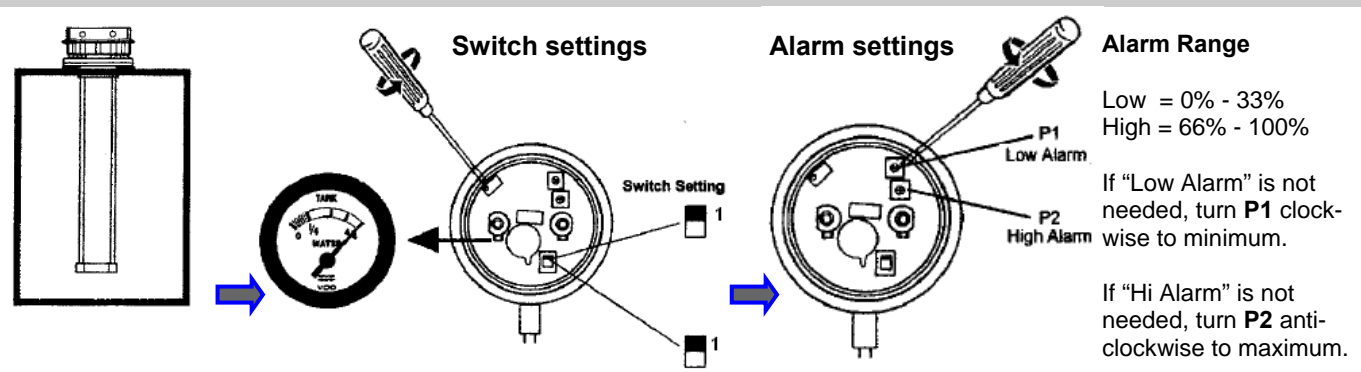
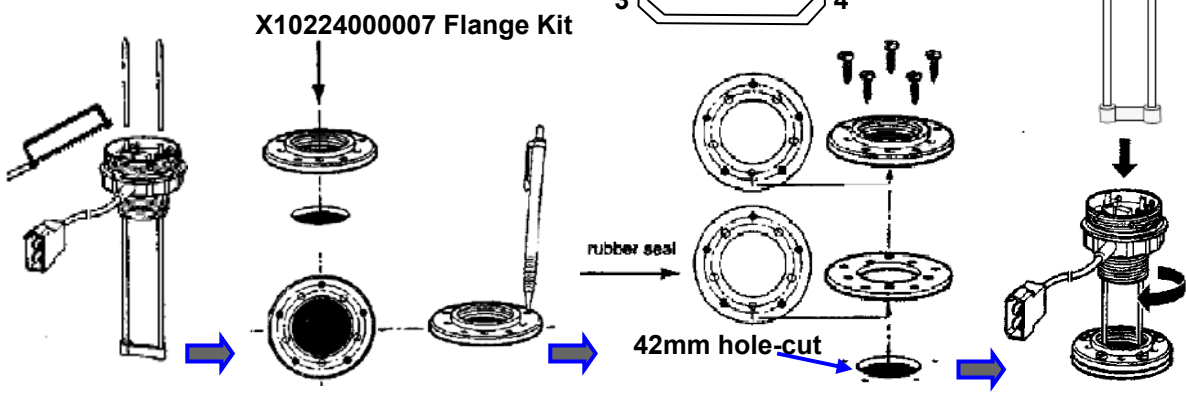

Temp Gauges 120° C and 150° C

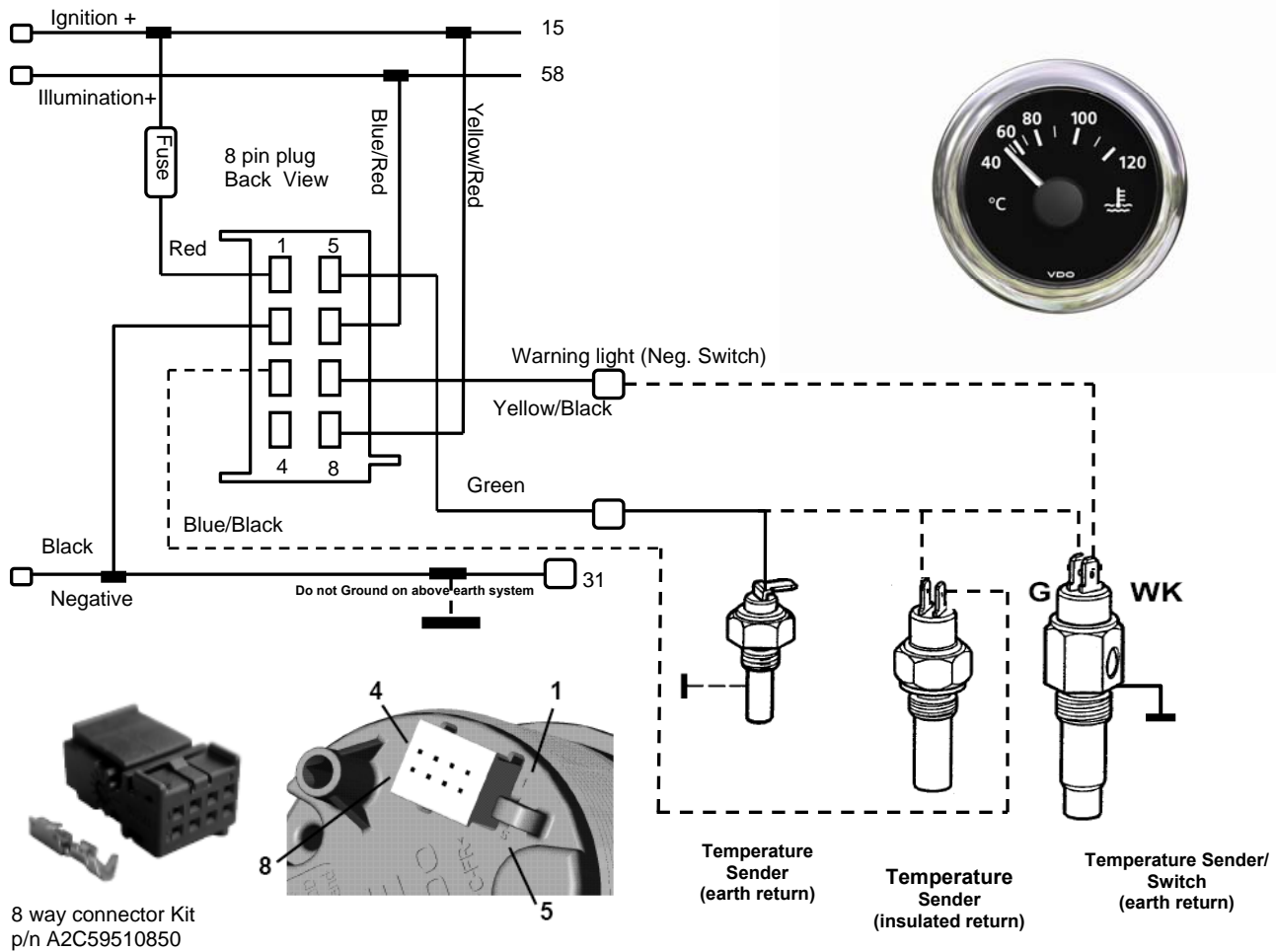

40 to 120 °C

Indication (°C)	40	50	60	70	80	90	100	110	120
Resistance (Ω)	287.4	193.3	134	95.2	69.1	51.3	38.6	29.4	22.7
Deflection (°∠)	0	3.3	8.3	15.5	25.8	40	58	75.2	88.2
Tolerance (°∠)	± 3.6	± 3.6	± 3.6	± 3.6	± 3.6	± 3.6	± 3.6	± 3.6	± 3.6

50 to 150 °C

Indication (°C)	50	80	90	100	110	120	130	140	150
Resistance (Ω)	322.8	112.5	83	62.2	47.5	36.5	28.9	23.1	18.6
Deflection (°∠)	0	12.4	19.8	29.6	42	56.8	69.7	80.2	88.1
Tolerance (°∠)	± 3.6	± 3.6	± 3.6	± 3.6	± 3.6	± 3.6	± 3.6	± 3.6	± 3.6

Pressure Gauges 2, 5, 7, 10 Bar

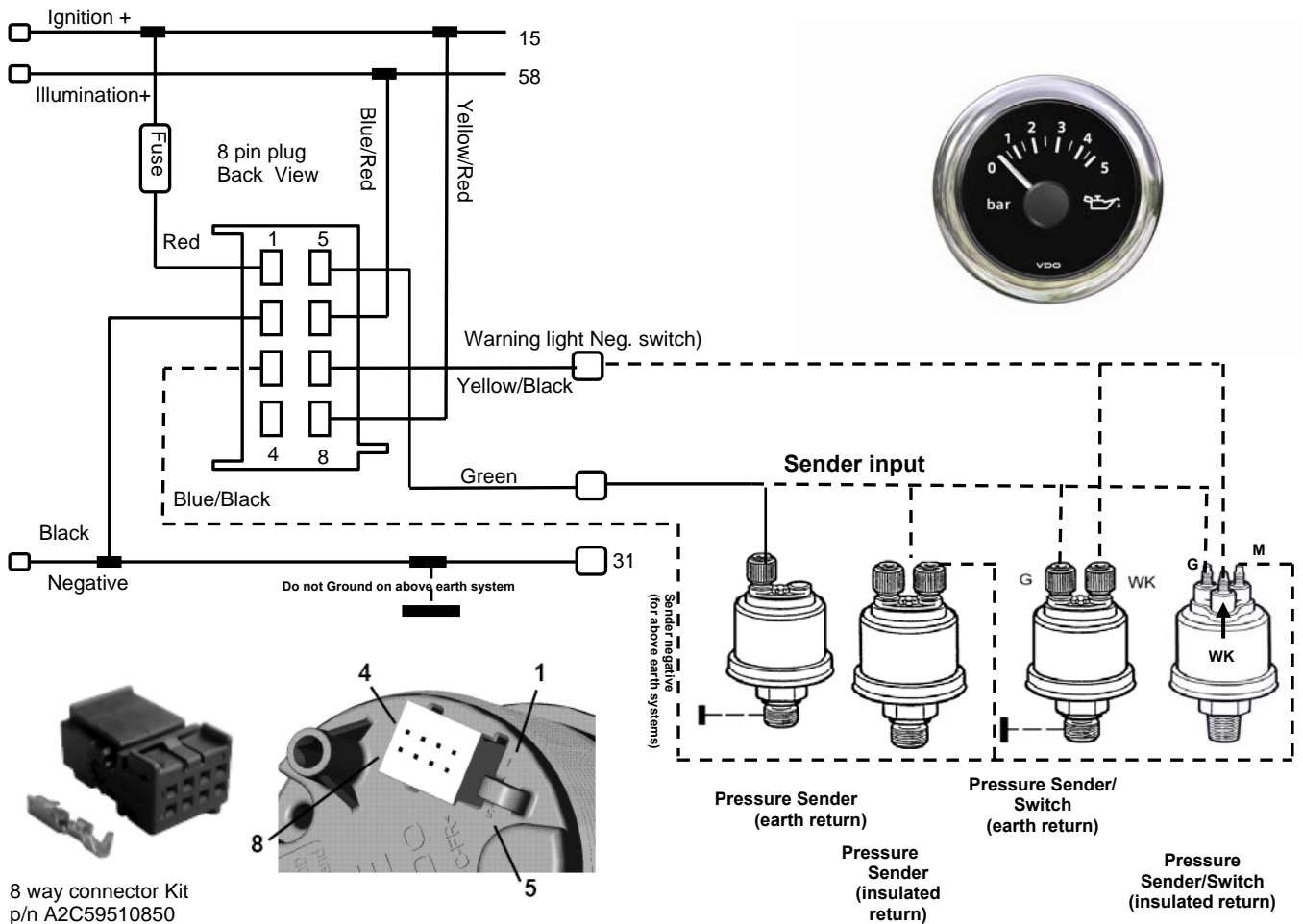

0 to 2 bar

Indication (bar)	0	1	2
Resistance (Ω)	10	99	184
Deflection ($^\circ\angle$)	0	41.4	87.4

0 to 5 bar

Indication (bar)	0	0.5	1	1.5	2	2.5	3	3.5	4	4.5	5
Resistance (Ω)	10	30	48	65	82	99	116	134	151	168	184
Deflection ($^\circ\angle$)	0	6.4	13.4	21.3	30.6	41.4	53	64.6	74.2	81.6	87.4

0 to 10 bar

Indication (bar)	0	1	2	3	4	5	6	7	8	9	10
Resistance (Ω)	10	31	52	71	88	106	124	140	155	170	184
Deflection ($^\circ\angle$)	0	6.8	15.2	24.4	34.3	46.2	58.3	68.2	76.1	82.4	87.4

Pressure Gauges 25, 30 Bar

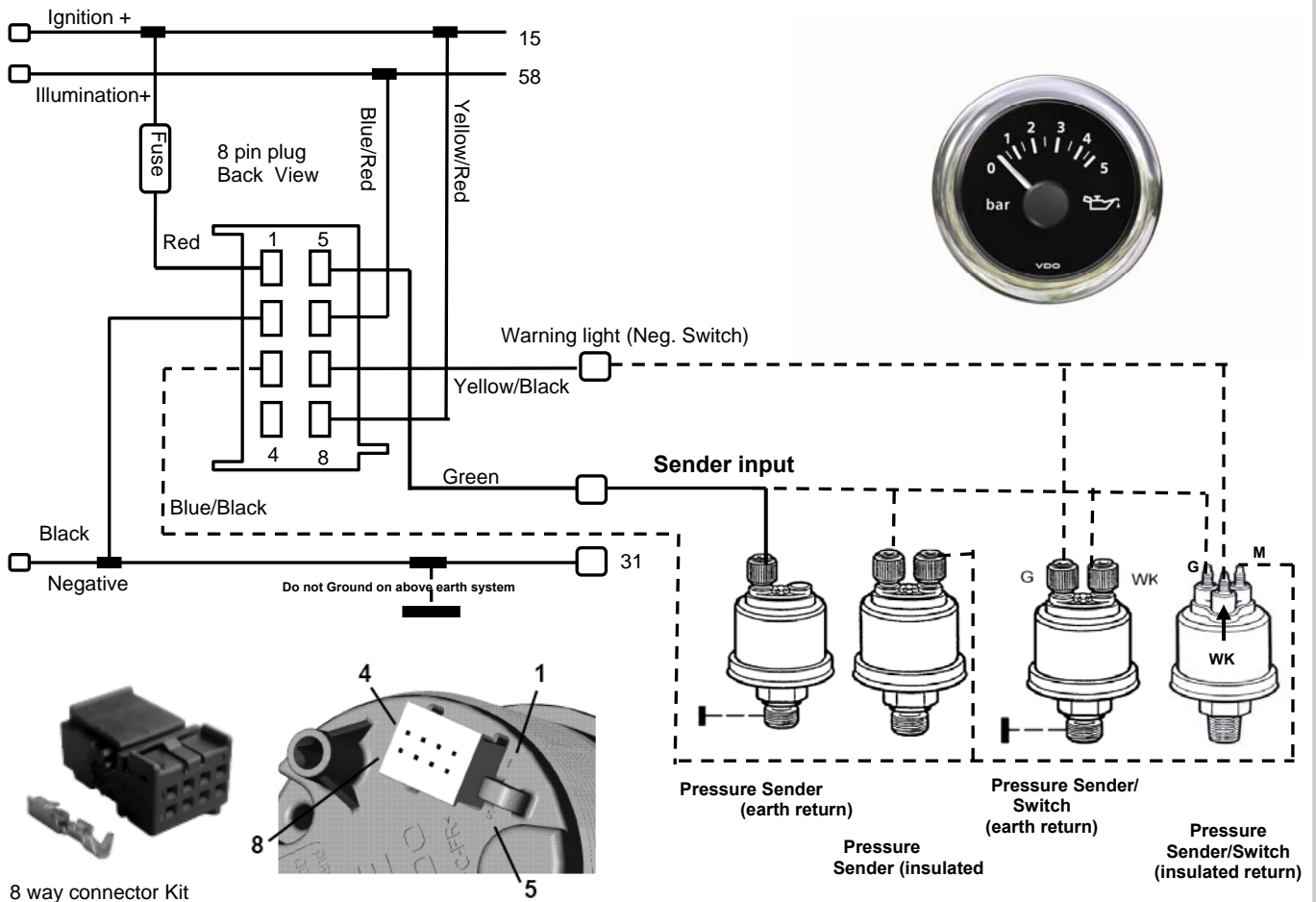

8 way connector Kit
p/n A2C59510850

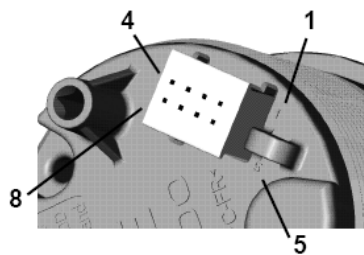

TIGHTENING TORQUES

- M10 x 1.0 10 Nm
- 1/8 – 27 NPTF 10 Nm
- M12 x 1.5 15 Nm
- 01.02.2020 15 Nm
- M14 x 1.25 20 Nm
- M14 x 1.5 20 Nm
- 1/4 – 18 NPTF 20 Nm
- 1/2 in. – 20 Whit. S 20 Nm
- 5/8 – 18 UNF-3A 20 Nm
- M16 x 1.5 30 Nm
- M18 x 1.5 30 Nm
- M20 x 1.5 30 Nm
- M22 x 1.5 30 Nm
- M24 x 1.5 30 Nm
- M26 x 1.5 30 Nm
- 3/8 – 18 NPTF 30 Nm
- 3/8 – 18 Dryseal NPTF 30 Nm
- 1/2 – 14 NPTF 30 Nm
- 3/4 – 16 UNF-3A 30 Nm
- R 3/8 30 Nm
- R 1/2 30 Nm

Note:

- Dual station senders have 1/2 of resistance range, Eg: 25 Bar is 92 Ohms
- For 0 to 30 Bar range application use a 0 to 25 Bar sender.

0 to 25 bar

Indication (bar)	0	2.5	5	7.5	10	12.5	15	17.5	20	22.5	25
Resistance (Ω)	10	32	53	73	92	109.1	125	143	155	169	184
Deflection ($^\circ\angle$)	0	7.1	15.6	25.5	36.8	42.7	58.9	69.9	76.1	82	87.4

Ammeter Gauges 30, 60, 100 & 150 AMPS

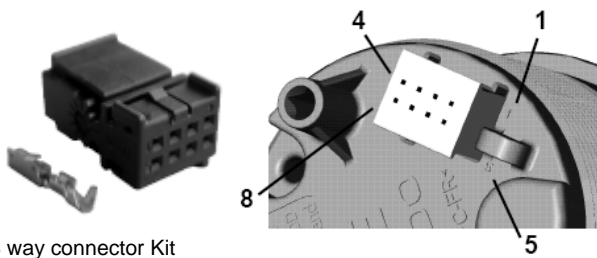
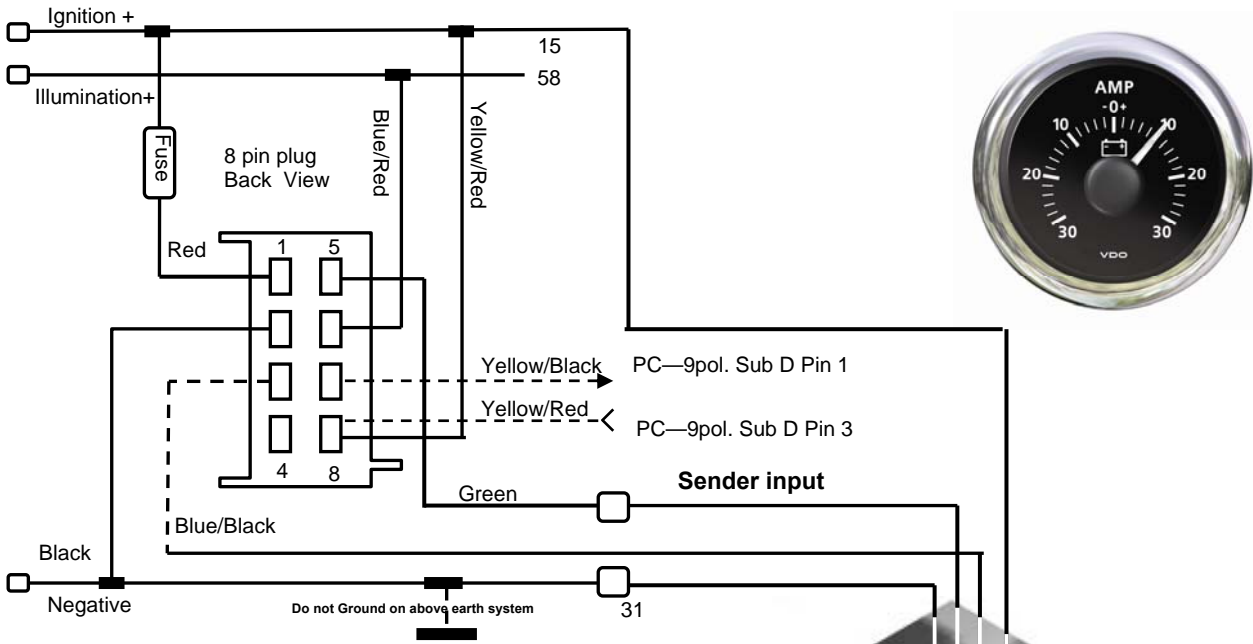

8 way connector Kit
p/n A2C59510850

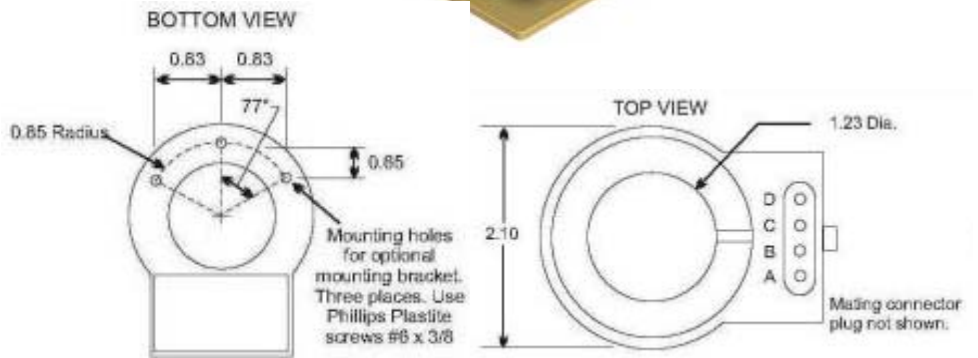

Various bracket mounting positions' example

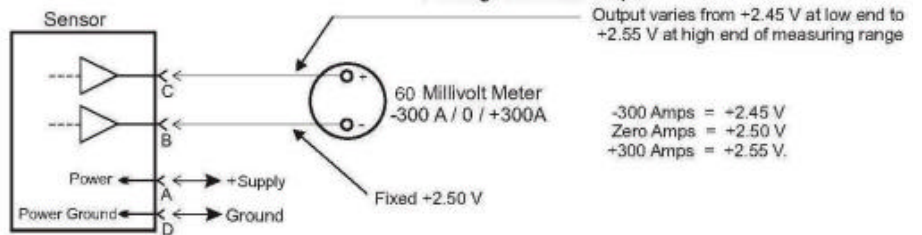
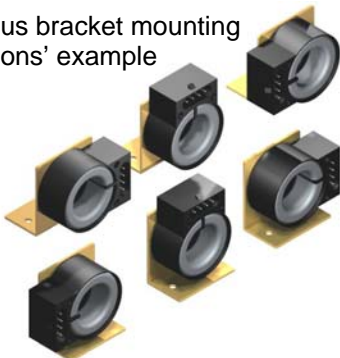

P/n **UK-UE-188** Universal Mounting Bracket Kit
P/n **UK-UE-184** Contactless Shunt Harness 3m

Clock wiring diagram

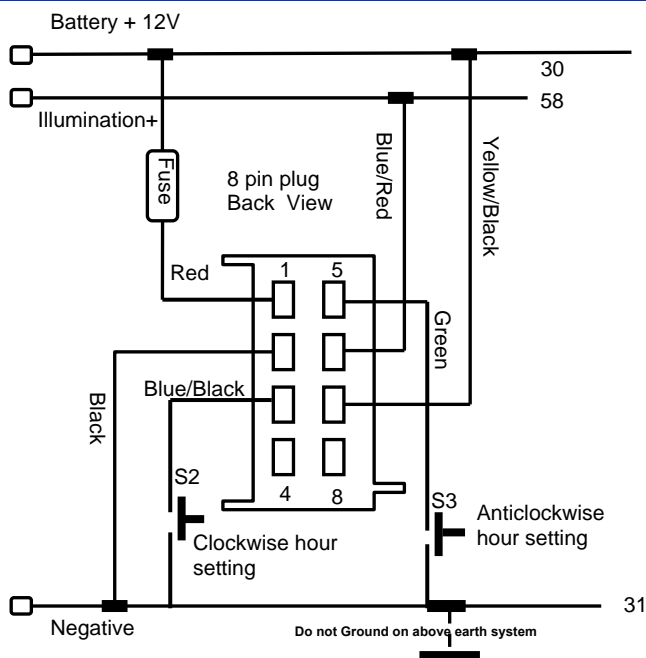

Hourmeter wiring diagram

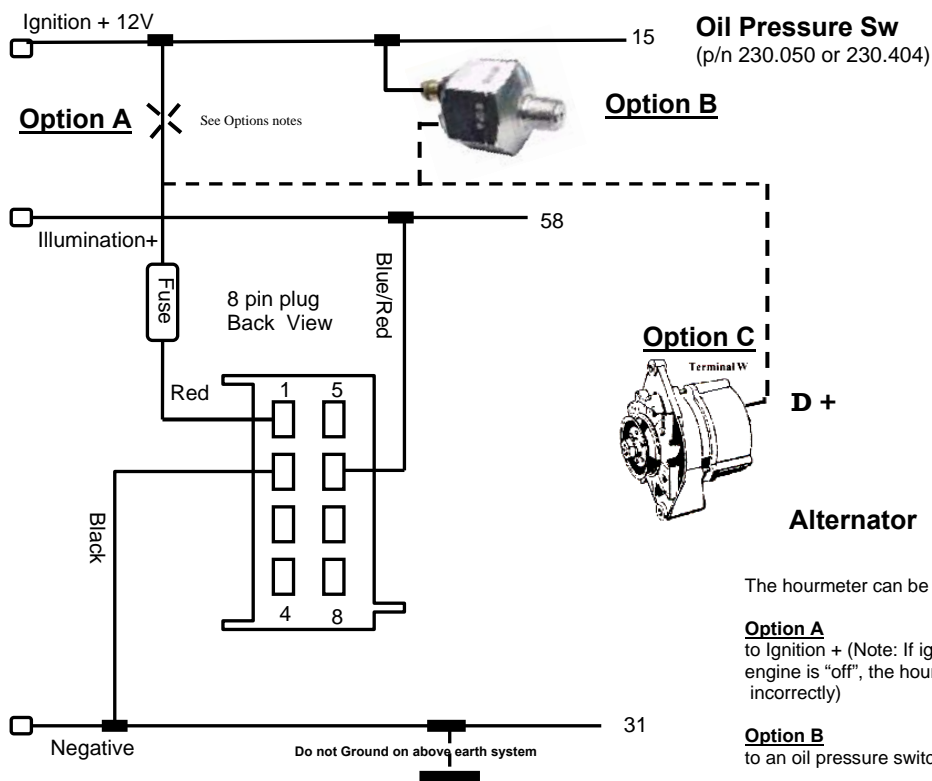

The hourmeter can be connected to a 12V supply, as follows:

- Option A**
to Ignition + (Note: If ignition power is let "on" and the engine is "off", the hourmeter will record engine time, incorrectly)
- Option B**
to an oil pressure switch (Normally "Off" contact).
- Option C**
to the alternator, terminal "D+"

Tank, Temp, Press, Trim, Rudder Angle 52mm Gauges

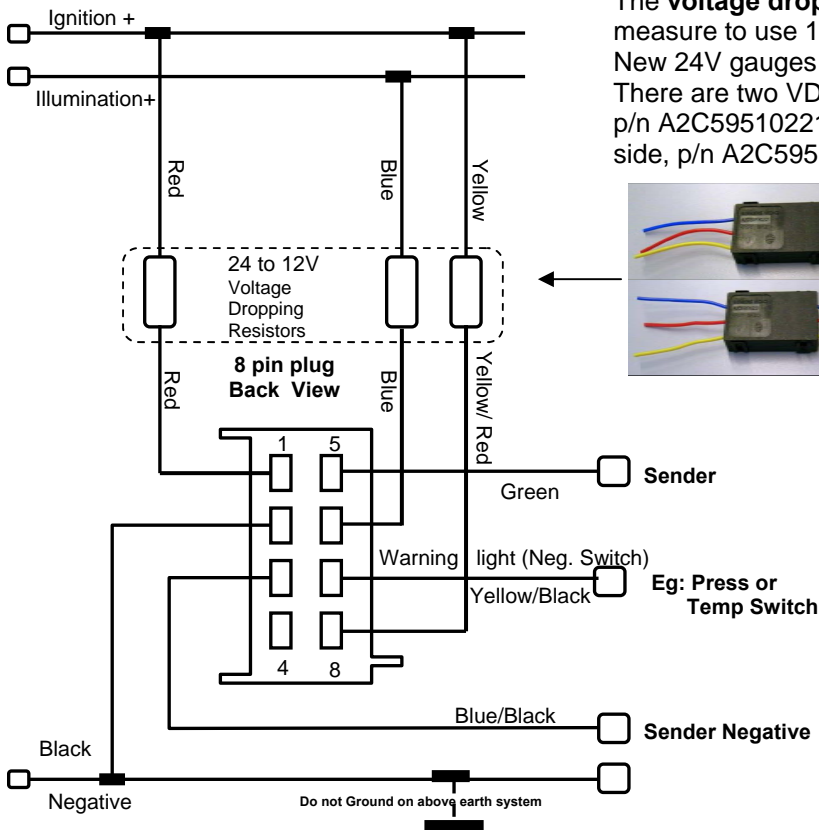

The **voltage dropping resistor (VDR)** module is a temporary measure to use 12V gauges on 24V application. New 24V gauges will be available from Aug 2011. There are two VDR versions, one with wires termination, p/n A2C59510221 and one with a pre-wired connector on one side, p/n A2C59510853.

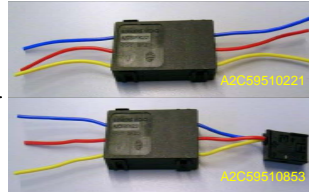

Note:

The VDR is used only on Ø52mm gauges with 90° meter movement, deflection. For Ø52mm gauges with 270° meter movement, deflection the VDR is not used as the gauges are 12/24V.

Electronic Alarm Switch

The Electronic Alarm Switch p/n A2C59510886 is designed to trigger the gauge's warning light at a pre-set point. It can be used on tank low level, high temp, low pressure, trim and rudder-angle. The unit has a pre-wired plug for the Viewline gauges. It operate on VDO and other manufactures (resistive) sensors.

Specification and technical data:

- Power supply:12VDC or24VDC
- Power consumption:< 10mA (warning lamp off)
- Operation temperature:-20°C to +70°C
- EMC:CE according to EMC Law89/336/EEC
- Vibration resistance:max.1g effective25 Hz –500Hz (duration8 hours)
- Shock:15g 1,5 ms half sine

Ø52mm gauges: Can be used on Temperature, Pressure, Tank, Trim, Rudder-angle.

Ø85/110mm: for optional warning lamps (Temperature, Pressure, Tank).



Adjustment/
operating mode 1-2
sensor selection 3-4

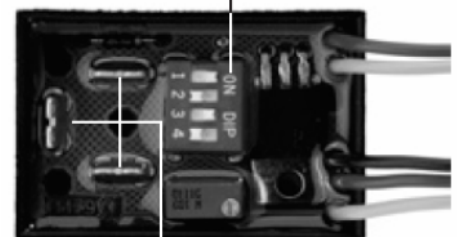

Connect sensor/
power connection

Gauges VDR & Warning Box



Electronic Alarm Switch p/n A2C59510886 - used a 24V application

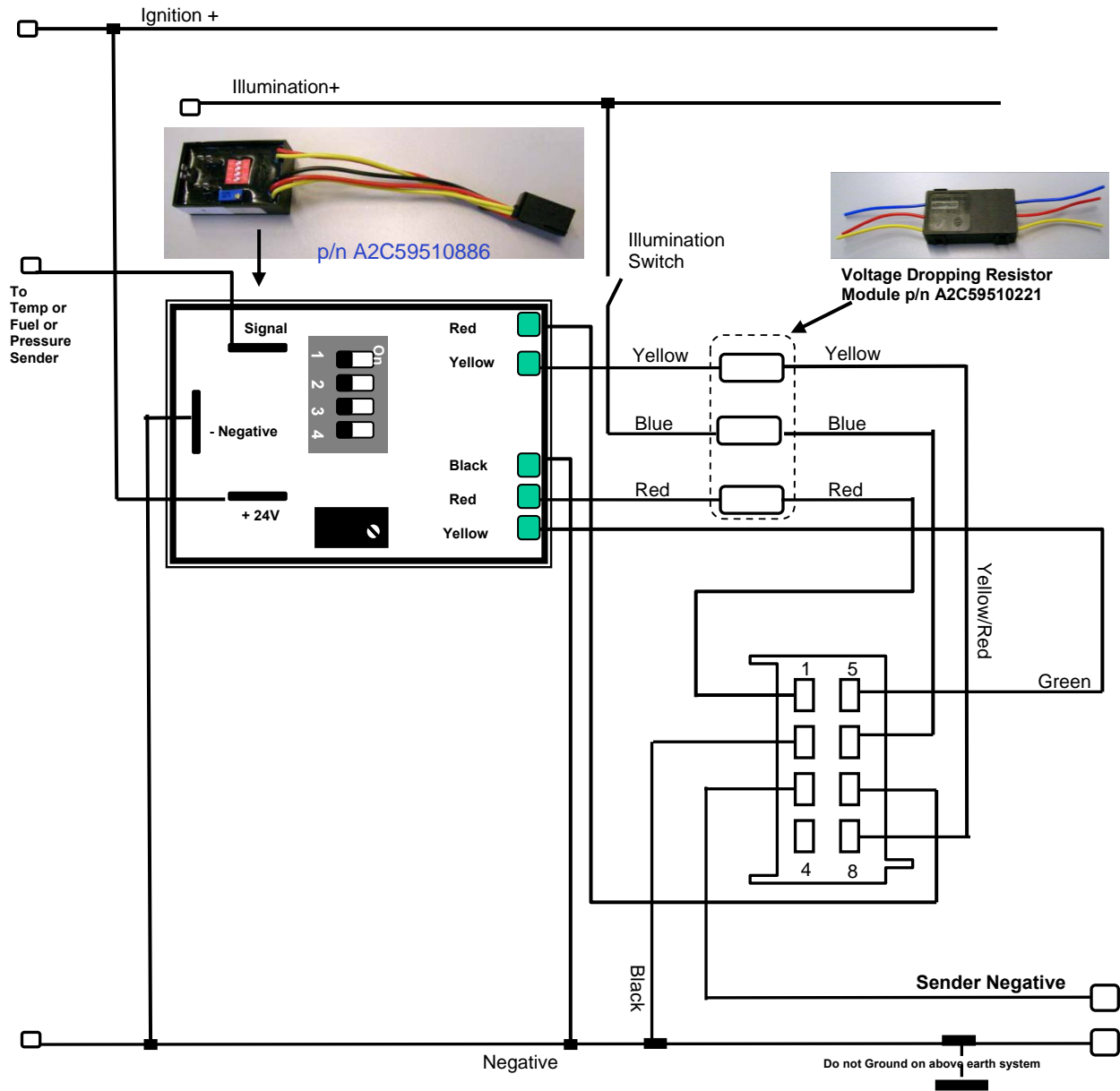

Gauges Overview



Round Bezel



Chrome Triangular Bezel



Black & White Triangular Bezel



Black & White Triangular Bezel



Bezels, Accessories and gauges details

Bezels for - Ø80/85mm & Ø52 mm Gauges

Type	Black	Chrome	White
flat	A2C53192911	A2C53192910	A2C53192912
round	A2C53192913	A2C53192914	A2C53192916
triangle	A2C53192917	A2C53192918	A2C53192920
Type	Black	Chrome	White
flat	A2C53186040	A2C53186023	A2C53186022
round	A2C53186027	A2C53186029	A2C53186028
triangle	A2C53186024	A2C53186026	A2C53186025



Bezel shapes

Accessories

Part number	Description
A2C59510854	VL Mounting Kit (studs and brackets) 52, 85, 110mm
A2C59510864	VL Mounting bracket flush mount
A2C53215641	VL Sealing Ring 85mm flush mount
A2C53215642	VL Sealing Ring 110mm flush mount
A2C59510850	Bush housing, 8-pin
A2C59510851	Bush housing, 14-pin
A2C53324664	Protective connector cap, 8-pin
A2C59513503	Adaptor cable Triducer® NMEA Sensor
A2C53324671	Protective connector cap, 14-pin
Tyco No. 539635-1	Hand pliers
Tyco No. 539682-2	Tool for hand pliers.
Tyco No. 1355718-1	Single contacts 0.14 – 0.22 mm ² tin plated
Tyco No. 963729-1	Single contacts 0.5 – 0.75 mm ² tin plated
Tyco No. 1355717-1	Strip 0.14 – 0.22 mm ² tin plated
Tyco No. 928999-1	Strip 0.25 – 0.5 mm ² tin plated
Tyco No. 963715-1	Strip 0.5 – 0.75 mm ² tin plated
Tyco No. 1355718-5	Single contacts 0.14 – 0.22 mm ² gold plated
Tyco No. 963726-5	Single contacts 0.25 – 0.5 mm ² gold plated
Tyco No. 963729-5	Single contacts 0.5 – 0.75 mm ² gold plated
Tyco No. 1355717-5	Strip 0.14 – 0.22 mm ² gold plated
Tyco No. 928999-5	Strip 0.25 – 0.5 mm ² gold plated
Tyco No. 963715-5	Strip 0.5 – 0.75 mm ² gold plated



Flush mounted



Front mounted gauges



Double lens



A2C59510850



A2C59510851



Terminal
(tin or gold plated)



Order Code: 3902160

Manufacturer Part No: 539635-1



Order Code: 1330232

Manufacturer Part No: 539682-2

Looms and Special application devices

P/n A2C59510852

Conversion loom between Vision or International gauge and Viewline Ø 52 mm / Ø 80-85 mm gauges

Oceanline to Viewline

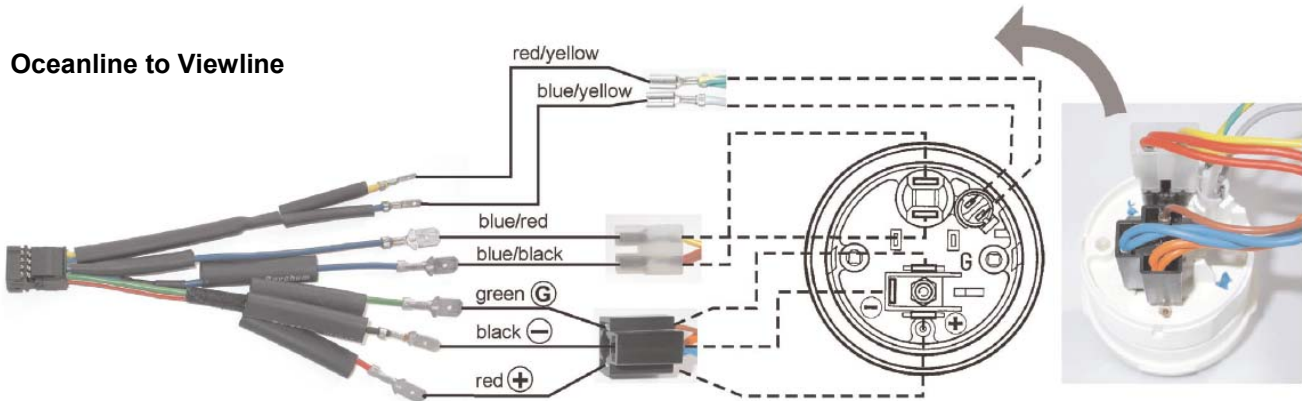

Vision & International to Viewline

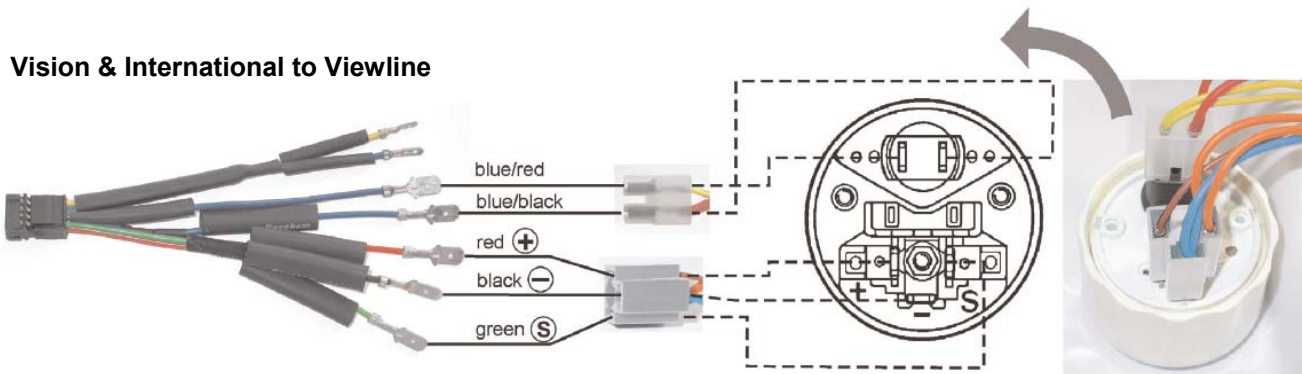

P/n A2C59512947

Harness with 8 terminals plug for Viewline Ø 52 mm / Ø 80-85 mm gauges



P/n 660.990

Over-Rev switch with single channel

The VDO RPM Switch has been designed to work with all standard ignition systems, and will provide a negative output once a predetermined RPM has been reached. In standard format the signal will turn off once the RPM falls below the pre-set point. Dip Switches are provided to program the level of hysteresis, or alternatively latch the relay on. Applications include driving a warning light or buzzer. Compatible with VDO Mega Light 600.895. 12V applications.



Switch Box 660.990

P/n 410.060

One channel, relay output warning switch

This module is designed to switch a 3A contact, in-built relay, at a preset voltage level. It can be used for thermatic fan, low fuel, high temp, low engine oil / transmission pressure, etc. alarm. The module can be connected to an existing sender/gauge or only to a sender.



12/24V

P/n 410.061

Three channels, warning switch

This module is designed to monitor three separate functions, by controlling three 1A transistors to switch negative when the pre-set alarm threshold is reached. It can be used to monitor/control thermatic fan, low fuel, high temp, low engine oil / transmission pressure, etc. The module can be connected to an existing sender/gauge or only to a sender.



12/24V

Amplifiers & Signal Processing Units

P/n 411.110

Signal interface

The VDO Signal Amplifier/Divider is a general purpose module designed to convert the signal from square wave to sine wave and vice versa. It can divide as well as multiply the frequency in small steps up to three times plus or minus. Ideal for calibrating electronic boat speedo or tachometers.



12/24V

P/n 410.020

Tachometer active signal filter

The VDO active filter can reduce the effect of electrical noise mixed with signal. This is in situation when the electrical interference is excessive and the speedo or tacho have a pointer fluctuation (erratic reading).



12/24V

P/n 411.096

Tachometer inductive sender, signal amplifier/Frequency Divider

The VDO Signal Amplifier/Divider is a general purpose module designed to work with most speedometer and tachometer signals. This box will amplify a low voltage signal to a 10V peak to peak square wave. This can be useful when a signal is too low to drive a speedometer, tacho, cruise control or any other such device. The signal may also be divided in frequency by a factor of 1, 2, 4, 8 or 16 to allow easier integration to another instrument.



12/24V

P/n 411.101

Over-Rev switch with two independent channels

A microprocessor controlled electronic switch module that can be programmed for a number of different functions. With two separate signal inputs switching two separate 5A relays contact the module can be a number of functions' combination. RPM, Speed Shaft rotation monitoring.



12/24V

Gauges bezel types

Ø 52 mm Gauges front fitting

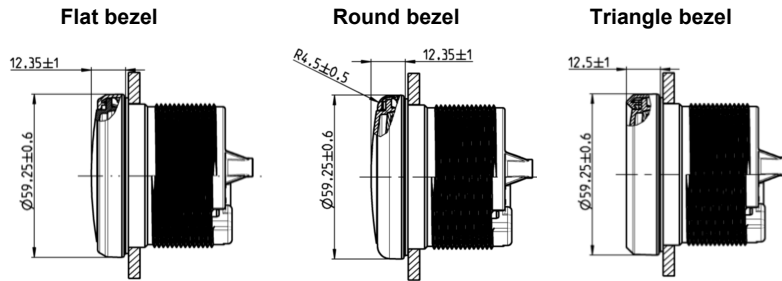

Ø 52 mm Gauges flush fitting

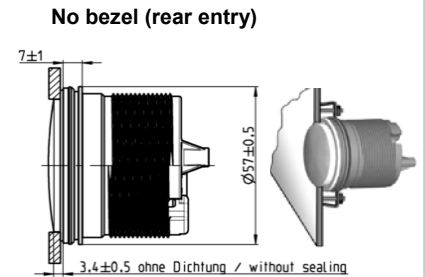

Ø 52 mm Gauge and Clamp-Ring overall dimension

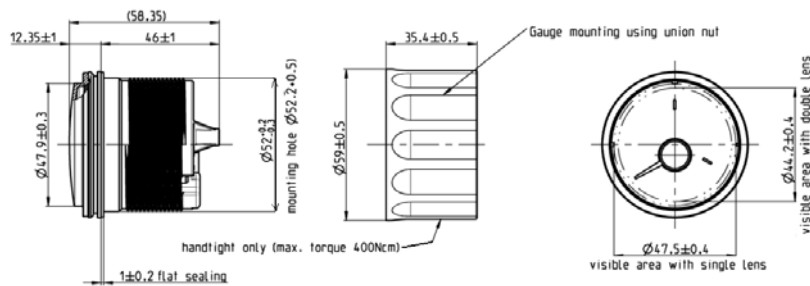

Ø 52 mm Gauges & Brackets

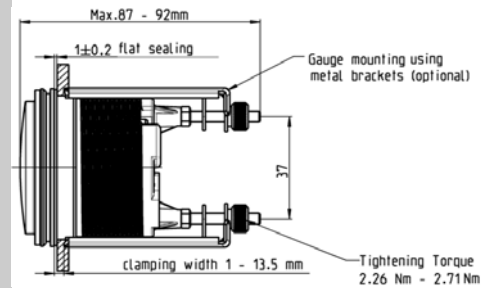

Ø 85 mm Gauges front fitting

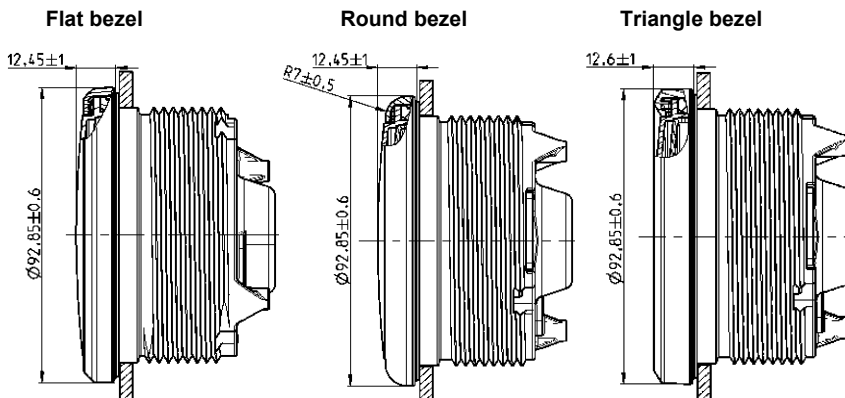

Ø 85 mm Gauges flush fitting

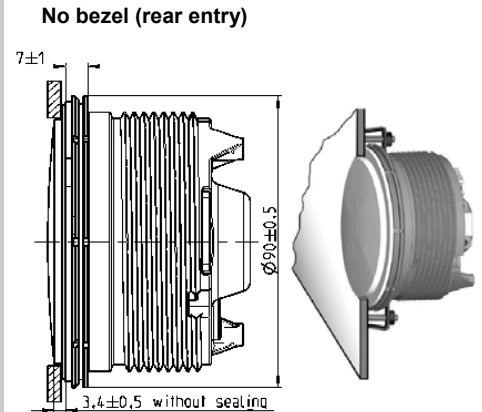

Ø 85 mm Gauge and Clamp-Ring overall dimension

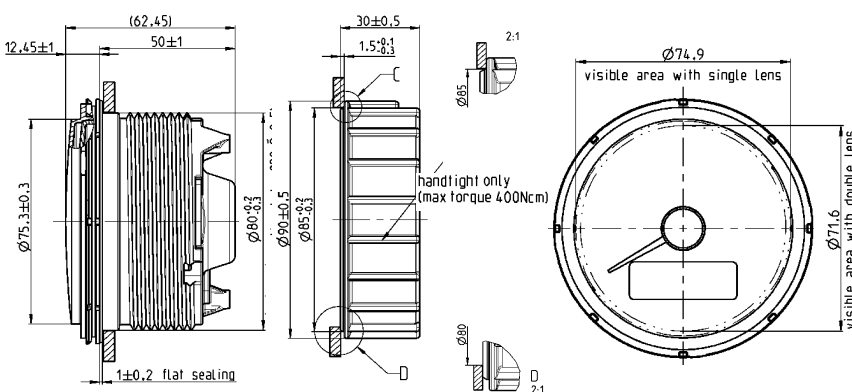

Ø 85 mm Gauges & Brackets

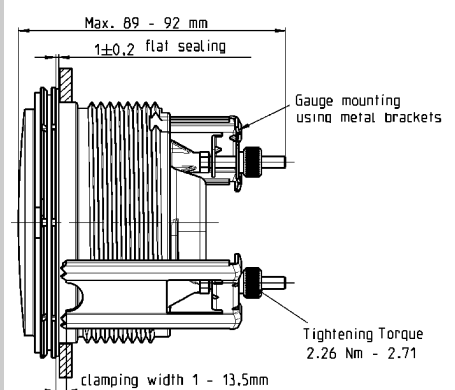

Gauges bezel types

Ø 110 mm Gauges front fitting

Flat bezel

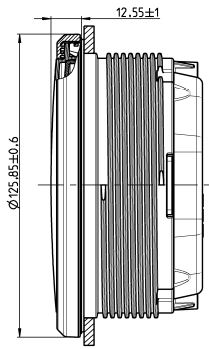

Round bezel

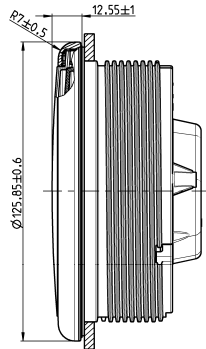

Triangle bezel

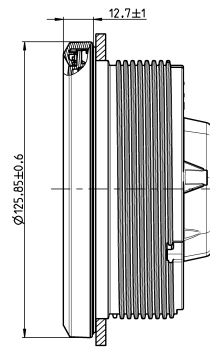

Ø 110 mm Gauges flush fitting

No bezel (rear entry)

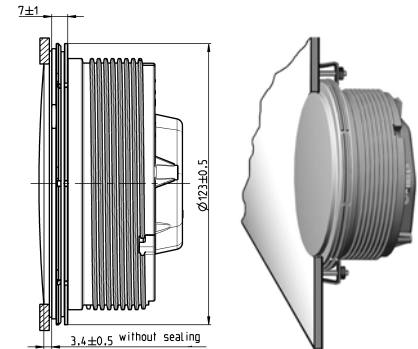

Ø 110 mm Gauge and Clamp-Ring overall dimension

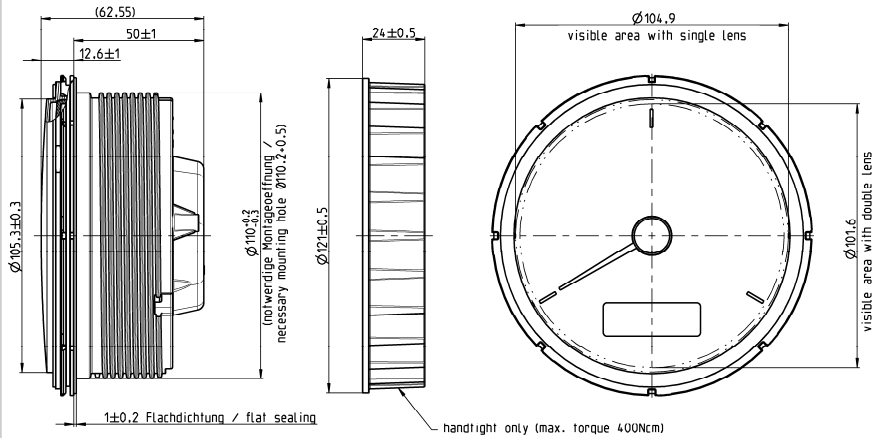

Ø 110 mm Gauges & Brackets

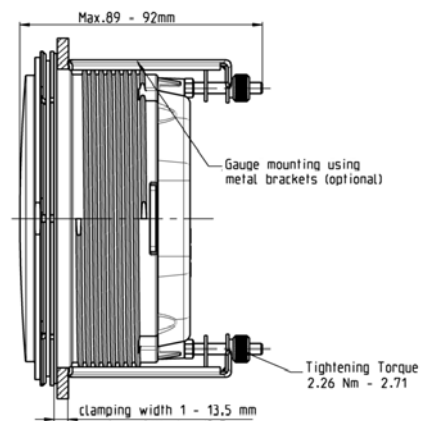

Sumlog

Technical Data

Measurement Range:	see Table
Sensors:	Sumlog SL/HS Sensor, Airmar Triducer [®] NMEA 0183
LCD-Size:	37 x 11 mm
Alarm output max:	100mA
Illumination:	amber, dimmable
Installation depth:	50mm
Installation diameter:	80 & 85mm
Deflection angle:	240°
Operating Voltage:	8,5 – 32 Volt (Sensor 8 – 16V)
Accuracy:	+/- 2,5% of full scale reading
Current consumption:	< 175 mA, including Warning LED
Operating temperature:	-20°C to +85°C; plated bezels (chrome) -20°C to +70°C
Storage temperature:	-40°C to +85°C for 48h; plated bezels (chrome) -40°C to +70°C +90°C for 1h
Temperature shock Range:	-40°C to +85°C; plated bezels (chrome) -40°C to +70°C
Transformation time:	10 seconds
Retention time:	2h
Climatic test Range:	+25°C to +55°C
Relative. Humidity:	80% to 100%
EMC:	in conformity with ISO 7637-1/2
ISO:	7637-3
ESD:	in conformity with DIN_EN 61000-4-2
ISO/CD:	10605
SAE:	J 551/15)
Vibration Sinus:	2g; 8-500Hz; duration 16h
Noise 4,2g; 10-1000Hz, duration 8h	
Mechanical shock continuous 25g; 6ms; 1Hz	
Single shock 100g; 11ms	
Free fall 1m; 3 times	
Chemical resistance against - preservative agent	
- preservative agent remover	
- cold cleaner	
- methylated spirit	
- interior cleaner	
- drinks containing caffeine and tannin	
Nominal position NL 0 to NL 85 (DIN16257)	
Protection class according to IEC 60529	
Front: IP67 (in Nominal position)	
Rear: IP52 (in Nominal position)	
Reverse polarity protection yes, 1 minute	
Short circuit protection yes, 1 minute	



Features

High reliability
Flush mount fitting
LED Illumination
Integrated Warning LED

Design

Housing PC; flame retarding (UL94)
Bezel PC or ABS; several colours and shapes (see table)
Lens PMMA; double lens
Dial backlight; different colours (see table)
Pointer backlight, white on black dials; red on white dials
Illumination Dial: LED amber (605nm)
Pointer: LED red (632nm)
Warning LED red (632nm), programmable
Mounting spin-lock Nut; locking height 0,5mm – 20mm,
optional Studs and Bracket; locking height 2 – 13mm
Connection 8 pin MQS connector system

Tachourmeter

Technical Data

Measurement Range:	see Table
Sensors:	Terminal 1 (Ignition Coil, negative side)
LCD-Size:	37 x 11 mm
Alarm output max:	100mA
Illumination:	amber, dimmable
Installation depth:	50mm
Installation diameter:	80 & 85mm
Deflection angle:	240°
Operating Voltage:	8,5 – 32 Volt (Sensor 8 – 16V)
Accuracy:	+/- 2,5% of full scale reading
Current consumption:	< 175 mA, including Warning LED
Operating temperature:	-20°C to +85°C; plated bezels (chrome)
Storage temperature:	-40°C to +85°C for 48h; plated bezels (chrome) -40°C to +70°C +90°C for 1h
Temperature shock Range:	-40°C to +85°C; plated bezels (chrome)
Relative. Humidity:	80% to 100%
Protection class	IP67 (front) in accordance to IEC 60529



Description

Gauge to indicate Engine Revolution, Engine Hours, Voltage & Clock.

Features

Integrated Warning LED
Changeable front bezel
LED Illumination
Flush mount possibility
High Reliability

Design

Housing PC; flame retarding (UL94)
Bezel PC or ABS; several colours and shapes (see table)
Lens PMMA; double lens
Dial backlight; different colours (see table)
Pointer backlight, white on black dials; red on white dials
Illumination Dial: LED amber (605nm)
Pointer: LED red (632nm)
Warning LED red (632nm), programmable
Mounting spin-lock Nut; locking height 0,5mm – 20mm,
optional Studs and Bracket; locking height 2 – 13mm
Connection 8 pin MQS connector system

(Differential Tacho)

Technical Data

Sensors: Hall sensor
Inductive sensor
Blocking oscillator
Ignition Terminal 1
Alternator Terminal W

Illumination: amber, dimmable

Installation depth: 50mm

Installation diameter: 80/85mm

Deflection angle: +/- 120°

Operating Voltage: 8,5 – 32 Volt

Accuracy: +/- 2,5% of full scale reading

Current consumption: < 175 mA, including Warning LED

Operating temperature: -20°C to +85°C; plated bezels (chrome) -20°C to +70°C

Storage temperature: -40°C to +85°C for 48h; plated bezels (chrome) -40°C to +70°C +90°C for 1h

Temperature shock Range: -40°C to +85°C; plated bezels (chrome) -40°C to +70°C

Transformation time: 10 seconds

Retention time: 2h

Climatic test Range: +25°C to +55°C

Relative Humidity: 80% to 100%

EMC in conformity with ISO: 7637-1/2
ISO 7637-3

ESD in conformity with DIN: EN 61000-4-2
ISO/CD 10605

SAE: J 551/15

Vibration Sinus: 2g; 8-500Hz; duration 16h

Noise 4,2g; 10-1000Hz, duration 8h

Mechanical shock continuous 25g; 6ms; 1Hz

Single shock 100g; 11ms

Free fall 1m; 3 times

Chemical resistance against - preservative agent

- preservative agent remover
- cold cleaner
- methylated spirit
- interior cleaner
- drinks containing caffeine and tannin

Nominal position NL 0 to NL 85 (DIN16257)

Protection class according to IEC 60529

Front: IP67 (in Nominal position)

Rear: IP52 (in Nominal position)

Reverse polarity protection yes, 1 minute



Features

High reliability
Flush mount fitting
LED Illumination
Integrated Warning LED

Concept

Housing PC; flame retarding (UL94)
Bezel PC or ABS; several colours and shapes (see table)
Lens PMMA; double lens
Dial backlight; different colours (see table)
Pointer backlight, white on black dials; red on white dials
Illumination Dial: LED amber (605nm)
Pointer: LED red (632nm)
Warning LED red (632nm), programmable
Mounting spin-lock Nut; locking height 0,5mm – 20mm, optional Studs and Bracket; locking height 2 – 13mm
Connection 8 pin MQS connector system

Press. - Temp. - Fuel - Trim - Ammeter - Volt - Pyro – Water

Technical Specs

- 8 pole Tyco/Hirschmann MQS plug
- +/-3.6 ° angle degree accuracy over the entire display area
- Operating voltage 10–16 volt, 16–32 volt with dropping resistor
- Current consumption < 130 mA with LED warning light
- Reverse polarity protection
- Input signal: standard Ohm values
- 90 ° display angle
- 52 mm installation diameter
- Anti-fog double lens
- Front panel in compliance with IP 67 protection rating
- Red LED warning light
- Optional makepoint



Fitting $\varnothing 52$ mm gauges

To replace a bezel

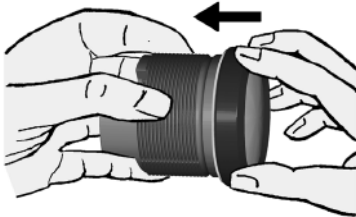

Place the new front ring on the instrument and press it on until it is flush with the instrument glass.



Front ring, flat; black	A2C53186040
Front ring, flat; white	A2C53186022
Front ring, flat; chrome	A2C53186023
Front ring, triangular; black	A2C53186024
Front ring, triangular; white	A2C53186025
Front ring, triangular; chrome	A2C53186026
Front ring, round; black	A2C53186027
Front ring, round; white	A2C53186028
Front ring, round; chrome	A2C53186029

To cut and fit gauge $\varnothing 52$ mm

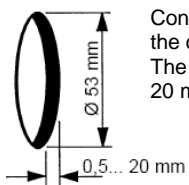

Conventional assembly. (Instrument is put into the drill hole from the front). The panel width may be within a range of 2 to 20 mm.

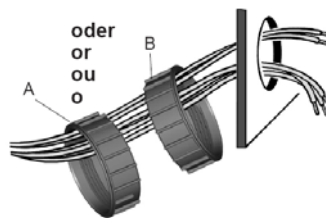

For 52 mm instruments, the fastening nut can be mounted at position A or B. This allows you to fix the gauge in different panel bores.

Version A

Clamping height 0.5 – 10 mm

Version B

Clamping height 0.5 – 20 mm



Align the instrument and hand-tighten the fastening nut. Ensure that the nut is not tightened with a torque greater than 400 Ncm.

* Make sure the seal lays flat between the panel and the front ring.

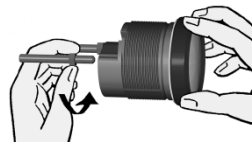

OR

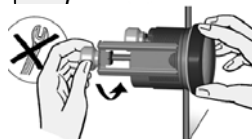

If you would like to omit the fastening nut, you may use the part set A2C59510854 as an alternative. This is recommended if the installation location is subject to vibratory loads. Screw the stud bolts into the provided drill holes in the enclosure. Max. stud bolt torque is 1.5 Nm.

Place the bracket on the stud bolt and hand-tighten the knurled nut.

To cut and fit gauge $\varnothing 52$ mm flush mount

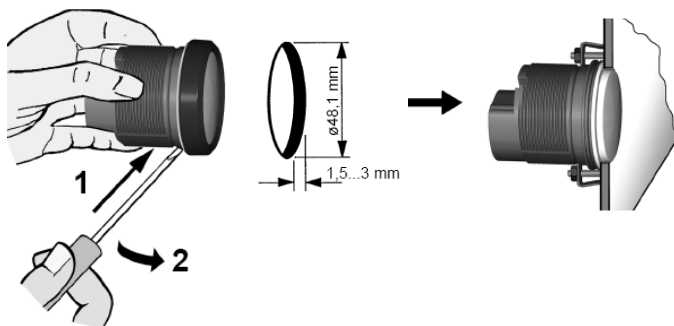

If the instrument is mounted flush (i. e., from the back so that the instrument glass and the panel form one plane), the front ring must be removed.

Press the instrument glass with both thumbs, while at the same time pressing the front ring forward from the instrument with both index fingers. Note the use of a tool in the adjacent figure.

Place the flush mount seal A2C53215640 on the instrument glass.

Put the instrument into the drill hole from the back. Adjust the instrument so that the gauge is level and fasten it to the stud bolts on the rear side of the panel, using the flush mount fixing bracket A2C59510864.

Fittings \varnothing 85mm gauges

To replace a bezel

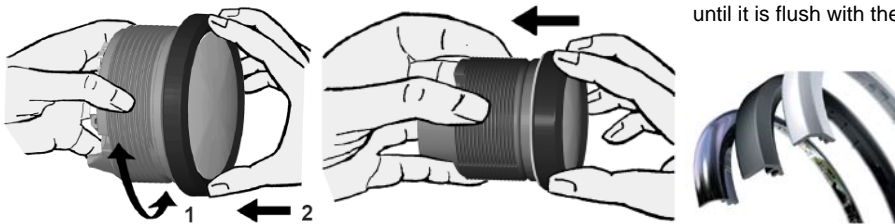

Place the new front ring on the instrument and press it on until it is flush with the instrument glass.

Front ring, flat; black	A2C53192911
Front ring, flat; white	A2C53192912
Front ring, flat; chrome	A2C53192910
Front ring, triangular; black	A2C53192917
Front ring, triangular; white	A2C53192920
Front ring, triangular; chrome	A2C53192918
Front ring, round; black	A2C53192913
Front ring, round; white	A2C53192916

To cut and fit gauge \varnothing 85mm

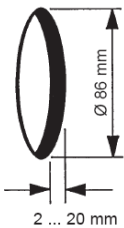

Conventional assembly. (Instrument is put into the drill hole from the front).
The panel width may be within a range of 2 to 20 mm.

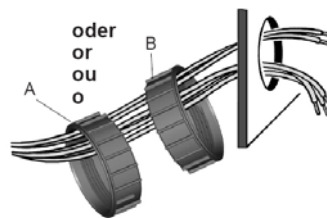

For 85 mm instruments, the fastening nut can be mounted at position A or B. This allows you to fix the gauge in different panel bores.

Version A Panel bore **80.5 - 81 mm**
Circumferential lip away from instrument

Version B Panel bore **85.5 - 86 mm**
Circumferential lip next to instrument

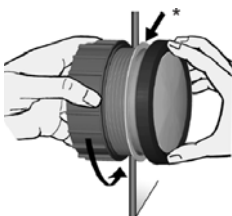

Align the instrument and hand-tighten the fastening nut. Ensure that the nut is not tightened with a torque greater than 400 Ncm.
* Make sure the seal lays flat between the panel and the front ring.

OR

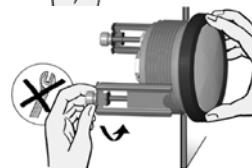

If you would like to omit the fastening nut, you may use the part set A2C59510854 as an alternative. This is recommended if the installation location is subject to vibratory loads. Screw the stud bolts into the provided drill holes in the enclosure. Max. stud bolt torque is 1.5 Nm.

Place the bracket on the stud bolt and hand-tighten the knurled nut.

To cut and fit gauge \varnothing 85mm flush mount

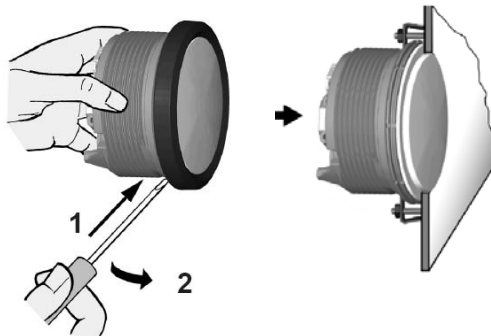
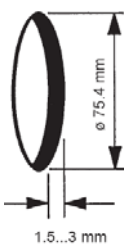

If the instrument is mounted flush (i. e., from the back so that the instrument glass and the panel form one plane), the front ring must be removed.

Press the instrument glass with both thumbs, while at the same time pressing the front ring forward from the instrument with both index fingers. Note the use of a tool in the adjacent figure.

Place the flush mount seal A2C53215641 on the instrument glass.

Put the instrument into the drill hole from the back. Adjust the instrument so that the gauge is level and fasten it to the stud bolts on the rear side of the panel, using the flush mount fixing bracket A2C59510864.

To unplug connector

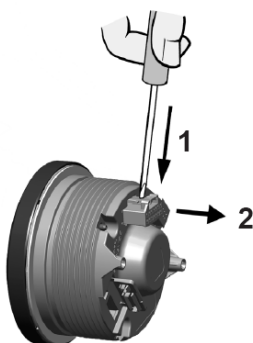

To remove the connector, press the latch (1) and pull the connector out (2).

Note: \varnothing 110 Gauges require a panel bore of \varnothing 111 mm.
Panel width may be within a range of 2 and 20 mm
Flush mount seal is p/n A2C53215642

Sumlog Calibration

Calibration for:

- **Hall Effect Output Transducer**

For NMEA Transducer Change "Input" to NMEA. No pulse calibration needed.

- ◆ Press the key briefly (< 2sec.) to change the currently displayed value.
- ◆ Press the key longer (< 2sec.) to change to the next value.
The display returns to normal operating mode (if a key is not pressed for 30 seconds. Any settings

To enter calibration mode

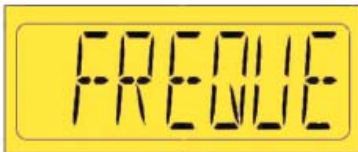

- ◆ Press and hold Configuration Key

Press the Config key to change over between the "Frequency" input (8 pole plug pin 5) and the NMEA0183 input (14 pole plug, pin 1 & 2)

- ◆ Press Configuration Key briefly

- ◆ Press and hold Configuration Key

Set impulses number is displayed.
The first digit flushes.

- ◆ Press Configuration Key briefly

The flushing digit increases by 1.
If the flushing digit is "9", the display returns to "0".

- ◆ Press Config key briefly

The next lower digit flushes

- ◆ Press Config key briefly

Deactivate Ignition power.
This saves the impulse number in the display.
Continue until the complete impulse number is set

- ◆ Press and hold Config key

Deactivate Ignition power (T15).
This saves the impulse number in the display.

Sumlog Alarm Threshold

Setting of unit and Alarm Threshold

- ◆ Battery Power **On** T. 30 (8-pin - Pin1)
- ◆ Ignition Power **Off** T. 15 (8-pin - Pin4)
- ◆ Press and hold Mode key (14-pin - Pin 12)



- ◆ Ignition Power **On** T. 15
- ◆ Release Mode key
- ◆ Press and hold Mode Key

By briefly pressing the Mode key, you can switch between 24h and 12h (AM/PM) clock format.

- ◆ Press and hold Mode key

Press the Mode key to change the water temperature unit from °C to °F.

- ◆ Press and hold Mode key

Press Mode key briefly to change the water depth unit from von m to ft.

- ◆ Press and hold Mode key

- ◆ Press and hold Mode key

- ◆ Press and hold Mode key

Set alarm threshold is displayed; the first digit flushes.

- ◆ Press Mode key briefly

The flushing digit increases by 1. If the flushing digit is "9", the display returns to "0".

- ◆ Press and hold Mode key

The next lower digit flushes in the display.

- ◆ Press Mode key briefly

The flushing digit increases by 1. If the flushing digit is "9", the display returns to "0". Continue until the complete alarm threshold is set.

- ◆ Press and hold Mode key

Switch **Off** Ignition power (T15).

This saves the unit and the alarm threshold in the display.

Sumlog Operation

Display Selection

- ◆ Switch **On** Battery Power T. 30 (8-pin - Pin1)
- ◆ Switch **On** Ignition Power T. 15 (8-pin - Pin4)

Odometer



- ◆ Press and hold Mode Key

Tripmeter



- ◆ Press and hold Mode key

Depth



- ◆ Press and hold Mode key

Time



- ◆ Press and hold Mode key

Water temperature



- ◆ Press and hold Mode key

Battery voltage



Resetting Trip Counter

- ◆ Switch **On** Battery Power T. 30 (8-pin - Pin1)
- ◆ Switch **On** Ignition Power T. 15 (8-pin - Pin4)

Press the Mode key repeatedly until the trip distance are displayed.



- ◆ Press and hold Mode key



- ◆ Trip is now deleted

Sumlog Clock & LCD Brightness Function

Setting the Clock

- ◆ Battery Power **On** T. 30 (8-pin - Pin1)
- ◆ Ignition Power **On** T. 15 (8-pin - Pin4)
- ◆ Press the Mode key repeatedly until the time is displayed
- ◆ Press and hold Mode key

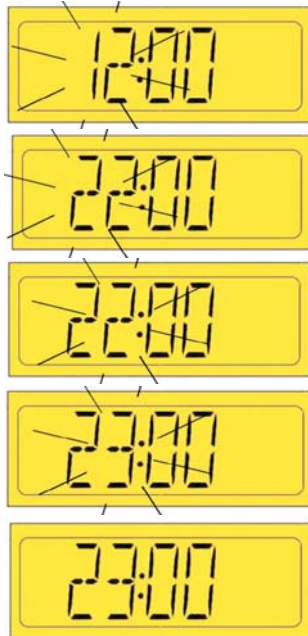

Set time is displayed; the first digit flashes.

- ◆ Press Mode key briefly

The flashing digit increases by 1. If the flashing digit is "9", the display returns to "0"

- ◆ Press and hold Mode key

The next lower digit flashes.

- ◆ Press Mode key briefly

The flashing digit increases by 1. If the flashing digit is "9", the display returns to "0".

Continue until the correct time is set

- ◆ Press and hold Mode key

Setting the Brightness

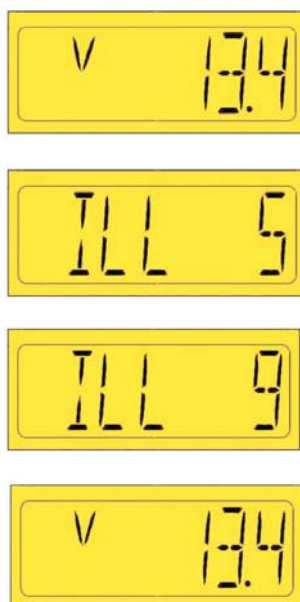

- ◆ Battery Power **On** T. 30 (8-pin - Pin1)
- ◆ Ignition Power **On** T. 15 (8-pin - Pin4)
- ◆ Press the Mode key repeatedly until the Voltmeter is displayed.

- ◆ Press Mode key briefly

- ◆ Press the Mode key repeatedly until the desired brightness is reached. The brightness can be set between 0 (OFF) to 10 (max).

- ◆ Press and hold Mode key

- ◆ The desired brightness is now permanently set.

Tachourmeter Calibration

Setting impulses / revolution

- ◆ Battery Power **On** T. 30 (8-pin - Pin1)
- ◆ Ignition Power **Off** T. 15 (8-pin - Pin4)
- ◆ Press and hold Configuration key (14-pin - Pin 12)

To enter calibration mode

- ◆ Ignition Power **On** T. 15
- ◆ Release Configuration key

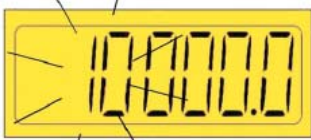

- ◆ Press and hold Configuration Key

Set impulse number is displayed, the first digit flashes.

- ◆ Press Configuration key briefly

The flashing digit increases by 1. If the flashing digit is "9", the display returns to "0"

- ◆ Press and hold Configuration Key

The next lower digit flashes

- ◆ Press Configuration Key briefly

The flashing digit increases by 1.
If the flashing digit is "9", the display returns to "0".
Continue until the complete impulse number is set

- ◆ Press and hold Configuration Key

Deactivate Ignition power T.15
This saves the impulse number in the display.

Tachourmeter Calibration

Setting the unit and alarm threshold

- ◆ Battery Power **On** T. 30 (8-pin - Pin1)
- ◆ Ignition Power **Off** T. 15 (8-pin - Pin4)
- ◆ Press and hold Mode key (14-pin - Pin 12)
- ◆ Ignition Power **On** T. 15
- ◆ Release Mode key



- ◆ Press and hold Mode key

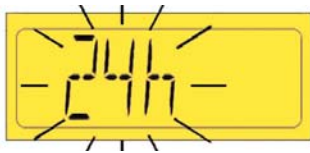

By briefly pressing the Mode key, you can switch between 24h and 12h (AM/PM) clock format.

- ◆ Press and hold Mode key



- ◆ Press Mode key briefly



- ◆ Press and hold Mode key



Set alarm threshold is displayed; the first digit flashes.

- ◆ Press Mode key briefly



The flashing digit increases by 1. If the flashing digit is "9", the display returns to "0"

- ◆ Press Mode key briefly

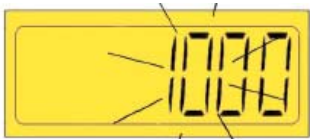

Set alarm threshold is displayed; the first digit flashes.

- ◆ Press Mode key briefly

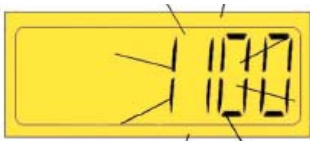

The flashing digit increases by 1. If the flashing digit is "9", the display returns to "0"

- ◆ Press and hold Mode key



Ignition Power **Off** T. 15.

This saves the unit and the alarm threshold in the display.

Tachourmeter Calibration

In operation Display indicator selection

- ◆ Battery Power **On** T. 30 (8-pin - Pin1)
- ◆ Ignition Power **On** T. 15 (8-pin - Pin4)

Total operating  hours

- ◆ Press Mode key briefly

Trip hours 

- ◆ Press Mode key briefly

Time 

- ◆ Press Mode key briefly

Vehicle voltage 

- ◆ Press Mode key briefly

Resetting the day counter

- ◆ Battery Power **On** T. 30 (8-pin - Pin1)
- ◆ Ignition Power **On** T. 15 (8-pin - Pin4)

Press the Mode key repeatedly until the trip hours are displayed.



- ◆ Press and hold Mode key



- ◆ Trip is now deleted.

Tachourmeter Calibration

Setting the Clock

- ◆ Battery Power **On** T. 30 (8-pin - Pin1)
- ◆ Ignition Power **On** T. 15 (8-pin - Pin4)
- ◆ Press the Mode key repeatedly until the time is displayed
- ◆ Press and hold Mode key

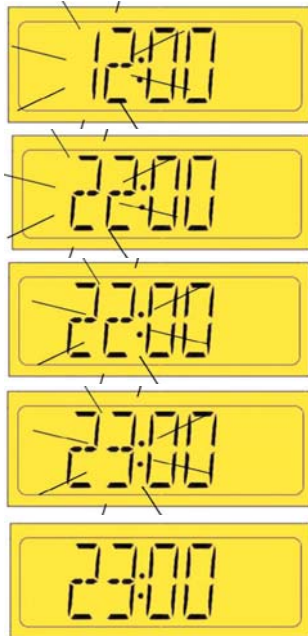

Set time is displayed; the first digit flashes.

- ◆ Press Mode key briefly

The flashing digit increases by 1. If the flashing digit is "9", the display returns to "0"

- ◆ Press and hold Mode key

The next lower digit flashes.

- ◆ Press Mode key briefly

The flashing digit increases by 1. If the flashing digit is "9", the display returns to "0".

Continue until the correct time is set

- ◆ Press and hold Mode key

Setting the Brightness

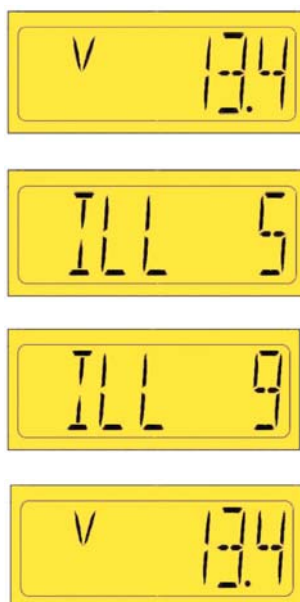

- ◆ Battery Power **On** T. 30 (8-pin - Pin1)
- ◆ Ignition Power **On** T. 15 (8-pin - Pin4)
- ◆ Press the Mode key repeatedly until the Voltmeter is displayed.

- ◆ Press Mode key briefly

- ◆ Press the Mode key repeatedly until the desired brightness is reached. The brightness can be set between 0 (OFF) to 10 (max).

- ◆ Press and hold Mode key

- ◆ The desired brightness is now permanently set.

Part Number Index



Part No.	Page	Part No.	Page	Part No.	Page	Part No.	Page
220.004	28	220.660-180	29	323801001008N	38	323805001015N	19
220.005	28	224011000015G	26	323801001009N	38	323809010006C	21
230.041	37	224011000016G	26	323801001010K	38	360081 030010C	36
230.044	37	224011000017G	26	323801001022K	38	360081 030014C	36
230.050	30	224011000017G	28	323801001040N	38	360081030001K	36
230.050	37	224011000018G	26	323801010001D	38	360081030002K	36
230.701	37	224011000019G	26	323803001002D	38	360081030009K	37
230.990	37	224011000020G	26	323803001004D	38	360081030015C	37
230.993	37	224011000021G	26	323803001006D	38	360081030017C	37
240.035	20	224011000022G	26	323803001008D	38	360081030022C	37
320.714	20	224011000023G	26	323803001011D	38	360081030028K	36
360.001	36	224011000024G	26	323803001012D	38	360081030039C	37
360.004	36	224011000025G	26	323803001013D	38	360081030049K	36
360.016	36	224011000026G	26	323803001019D	38	360081030052C	37
1501120004	16	224011000027G	26	323803004002D	38	360081032001C	36
22502641141	28	224011000028G	26	323805001001K	38	360081032002C	36
230112005006	37	224011000029G	26	323805001002C	38	360081032003C	22
230213002001	37	224011000030G	26	323805001004K	38	360081032006C	22
230213002004	37	224011000031G	26	323805001005N	38	360081032011C	21
220.150-180	25	226801015001C	24	323805001007N	38	360081032014C	22
220.150-180	29	232011005004D	39	323805001015N	38	360081032025C	36
220.180-180	25	232011005027D	39	323805002007D	38	360081032025C	21
220.180-180	29	232011005030D	39	323805003001N	38	360081038001C	23
220.230-180	25	232011017004D	39	323805003002N	38	360081038001C	23
220.230-180	29	232011017009D	39	325801002002D	38	360081038002C	23
220.250-180	25	232011017010D	39	325805003001C	38	360081038002C	23
220.260-180	25	232011017016D	39	325805003002C	38	360081038003C	23
220.260-180	29	232011017017D	39	323805001001K	19	360081038003C	23
220.270-180	25	232011017032D	39	323805001001K	19	360081039002C	36
220.270-180	29	232011017034D	39	323805001001K	19	360081039003C	37
220.300-180	25	232011017038D	39	323805001002C	19	360081039004C	36
220.300-180	29	232011017080D	39	323805001002C	19	362081001001K	36
220.320-180	25	232011017087D	39	323805001004K	19	362081001002K	36
220.320-180	29	232011017099D	39	323805001004K	19	362081002001K	36
220.330-180	25	232011017103D	39	323805001005N	19	362081003002K	36
220.330-180	29	232011017131D	39	323805001005N	19	362081004001C	36
220.350-180	25	232011017148D	39	323805001007N	19	395024004005C	35
220.600-180	25	232011019003D	39	323805001007N	19	395024004008C	36
220.600-180	29	323801001006K	38	323805001007N	19	395262001005G	34
220.660-180	25	323801001007N	38	323805001015N	19	395262001007C	34

Part Number Index



Part No.	Page	Part No.	Page	Part No.	Page	Part No.	Page
395262001015G	34	A2C59512410	32	A2C59512328	31	N02311556	33
395462001001G	34	A2C59512411	32	A2C59512329	31	N02413058	33
395462001002G	34	A2C59512453	30	A2C59512330	31	N02413066	33
395462001004G	34	A2C59512454	30	A2C59512331	31	N02240106	24
395462001005C	34	A2C59512458	31	A2C59512342	30	N05801432	28
395462001006G	34	A2C59512459	31	A2C59512343	30	UK-UE-094	31
440102001001D	32	A2C59512545	31	CTA0200	28	UK-UE-157	31
440102002001D	32	A2C59512546	31	N02 140 158	33	UK-UE-184	31
A2C59510165	24	A2C59512561	32	N02 140 160	33	UK-UE-188	31
A2C59510166	24	A2C59512562	32	N02 224 082	33	X10224000007	30
A2C59510166	28	A2C59512564	32	N02 311 058	33	X10232001001	39
A2C59510167	24	A2C59513443	32	N02 311 060	33	X10232001002	39
A2C59510167	28	A2C59513444	32	N02 413 060	33	X10232001003	39
A2C59510171	24	A2C59513445	32	N02 413 074	33	X10232001004	39
A2C59510172	24	A2C59513446	32	N02012920	33	X10232001005	39
A2C59510172	28	A2C59512499	27	N02012922	33	X10232001006	39
A2C59510173	24	A2C59512503	28	N02012928	33	X10232001007	39
A2C59510173	28	A2C59512505	28	N02012930	33	X10232001008	39
A2C59510366	29	A2C59512508	24	N02140154	33	X10232001009	39
A2C59510368	29	A2C59512508	25	N02140156	33	X10232001010	39
A2C59512332	20	A2C59512509	26	N02140508	33	X11719000053	16
A2C59512333	20	A2C59512509	27	N02140512	33	X11719000058	16
A2C59512334	20	A2C59512510	28	N02140516	33	X10-224-009-019	27
A2C59512335	20	A2C59512511	28	N02224080	33	X10-224-009-022	27
A2C59512336	21	A2C59512548	19	N02226002	33	X10-224-009-026	27
A2C59512338	21	A2C59512550	19	N02240902	30	X10-224-009-029	27
A2C59512344	17	A2C59512550	19	N02240904	30	X10-224-009-037	27
A2C59512345	17	A2C59512555	19	N02240906	30	X10-224-009-039	27
A2C59512346	17	A2C59512556	19	N02270040	33	X10-224-009-040	27
A2C59512347	17	A2C59512556	19	N02311054	33	X10-224-009-048	27
A2C59512348	17	A2C59512599	21	N02311056	33	X10-224-009-053	27
A2C59512349	17	A2C59512601	22	N02311536	33	X10-224-009-057	27
A2C59512396	17	A2C59512603	22	N02311540	33	X10-224-009-072	27
A2C59512397	17	A2C59512605	23	N02311542	33	X10-224-014-002	27
A2C59512398	17	A2C59512607	23	N02311544	33	X10-224-014-003	27
A2C59512399	17	A2C59512617	21	N02311546	33	X10-224-014-011	27
A2C59512402	18	A2C59512618	22	N02311548	33	X10-224-014-015	27
A2C59512403	18	A2C59512619	22	N02311550	33	X10-224-014-021	27
A2C59512407	16	A2C59512620	23	N02311552	33	X10-224-014-022	27
A2C59512408	16	A2C59512621	23	N02311554	33	X10-224-014-031	27

Part Number Index



Part No.	Page	Part No.	Page	Part No.	Page	Part No.	Page
X10-224-014-044	27	CW700012	4	ITA-039-UWL-639	5	ITA-039-UWL-629	5
X10-224-021-002	27	CW700013	4	ITA-039-UWL-639	5	ITA-039-UWL-649	5
X10-224-021-004	27	CW700014	4	ITA-039-UWL-519	5	ITA-039-UWL-529	5
X10-224-021-005	27	CW700015	4	ITA-039-UWL-539	5	ITA-039-UWL-549	5
X10-224-021-006	27	CW700016	4	ITA-039-UWL-519	5		
CW700011	8	ITA-039-UWL-619	5	ITA-039-UWL-539	5		

Warranty Policy

Continental Pty Ltd (VDO) warrants the goods against defects in factory workmanship and materials within the warranty period.

The warranty period for automotive, commercial and marine products shall be 24 months from the date of invoice, subject to the usage limitation of 100,000 Km for goods installed in commercial vehicles.

The warranty period for audio and navigation products shall be 24 months from date of invoice.

The warranty period for repaired items shall be 90 days from the date of invoice.

The customer must notify the point of purchase / distributor of any defect coming within the provisions of this warranty within 30 days of the fault occurring.

A copy of the relevant invoice or the relevant invoice number as proof of the date of purchase must be provided with returned goods.

Continental P/L (VDO) liability with respect to this warranty shall be limited at the option of Continental P/L (VDO) to repair or replacement of the goods.

Removal and refitting costs and all freight costs associated with the warranty claims are the responsibility of the customer.

This warranty shall not apply to goods which have been opened by a third party. Contaminated by oil, water or grease, fitted in excessive vibration environments or improperly connected.

Glass and capillary breakages are excluded from the provisions of this warranty.

Save and except for the express warranty set out above and to the maximum extent permitted by law, all conditions and warranties which may at the time be implied by common law, Trade Practices Act, Fair Trading Act, Goods Act or any other state or Federal Act are excluded.

To the extent that these cannot be excluded and where the law permits.

Continental's liability in respect of any such condition or warranty, shall be limited at the option of Continental P/L (VDO) to repair or replacement of the goods or the supply of equivalent goods or the payment of the costs of the replacing or repairing the goods, or having them replaced or repaired.

The information provided in this brochure contains only general descriptions or performance characteristics, which do not always apply as described in case of actual use or which may change as a result of further development of the products. This information is merely a technical description of the product. This information is not meant or intended to be a special guarantee for a particular quality or a particular durability. An obligation to provide the respective characteristics shall only exist if expressly agreed in the terms of contract. We reserve the right to make changes in availability as well as technical changes without prior notice.

