

# KIMAX 2



## KIMAX 2 Radio

### **Installation and Instruction manual**

Software version 2.90 and up

## Table of contents

Table of contents .....	2
How does it work? .....	4
Daily use .....	6
Kimax 2 Menu .....	10
Entering the Kimax 2 menu .....	11
Configuration .....	18
Calibration .....	21
Protecting your setup and calibration .....	25
Electrical installation .....	26
Serial outputs .....	29
Alarms .....	31
Sensor installation .....	32
Air sensor installation.....	32
SG-sensor installation (electrical installation) .....	35
Frequently Asked Questions .....	37
Additional information .....	38
Basic test setup.....	40
Calibration Scheme.....	41
Notes .....	42

This manual is edited for the Kimax 2 Radio. The menus and diagrams are also referring to the layout of the Kimax 2 Radio. This manual is primarily describing the standard functions for the Kimax 2 Radio. However variations from this manual can occur. To learn more about possible versions and special functions, visit [www.kimax.com](http://www.kimax.com) or contact your local Kimax distributor or Sense-Tech Weighing Systems ApS.

## Warranty

Kimax 2 Radio is covered by Sense-Tech Weighing Systems ApS guarantee. Electronic failure and broken components caused by normal use are repaired or exchanged when necessary, when sent to the factory.

Damage to your vehicle caused by installation of Kimax instruments or loss of time caused by recalibration or repairments of Kimax instruments are not covered by Sense-Tech Weighing Systems ApS in any case.

## Basic safety rules

Before you start the installation procedure, make sure that the instruments have not suffered any damage during transport.

**Note that the Kimax 2 instruments must be installed and connected in accordance with the regulations valid for the vehicle and country in question.**

**The Kimax 2 instruments must be protected from gravel, water spray from wheels and other factors that may damage the instruments.**

**We recommend to mount the instruments in a position where it is protected from water jets and rinse water.**

Once you have decided where the instrument is to be mounted in the cabin, you have to consider the cable routing.

Special attention should be given to potential damaging factors such as e.g. hinging point for tilting the cab.

Once you have decided where the instrument is to be mounted on the chassis, you have to consider the cable routing. Special attention should be given to tensile forces, cuts and other factors that may damage the cables and hoses.

## Connection of compressed air

**Before you carry out any installation work related to the air suspension, make sure that the suspension has been brought to the lowest possible position.**

## Electrical connection

**Always disconnect the battery before you perform any installation work on the system of the vehicle.**

## How does it work?

The Kimax 2 on board scale is an axle pressure meter that for instance measures the pressure on the air suspension system to indicate the load on each axle of the entire vehicle.

The Kimax 2 Radio has a 3-digit display indicating the actual weight of the vehicle or the weight of the individual axles. LEDs warn the driver in case of overload.

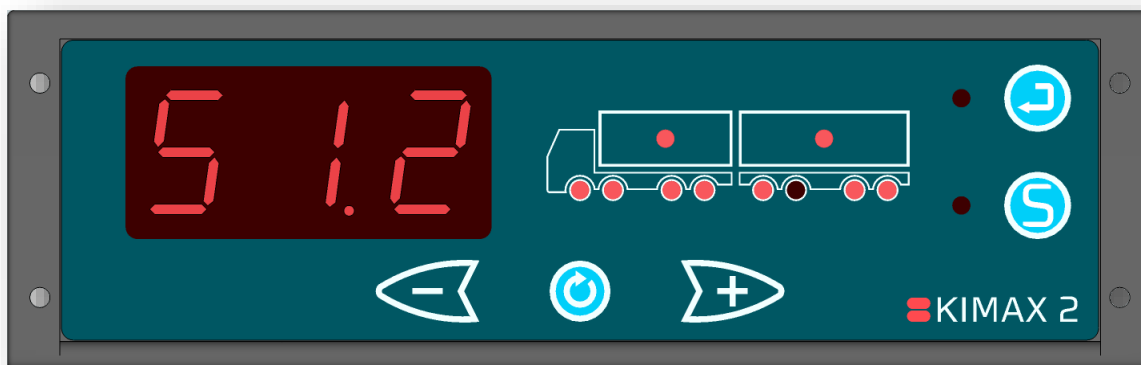

A mechanical or electronic system on the vehicle maintains a fixed level of the chassis height through a level valve which adds or subtracts compressed air to the bellows according to the actual load on the vehicle.

The top of the bellows, shock absorber and level valve are fixed on the chassis of the vehicle.

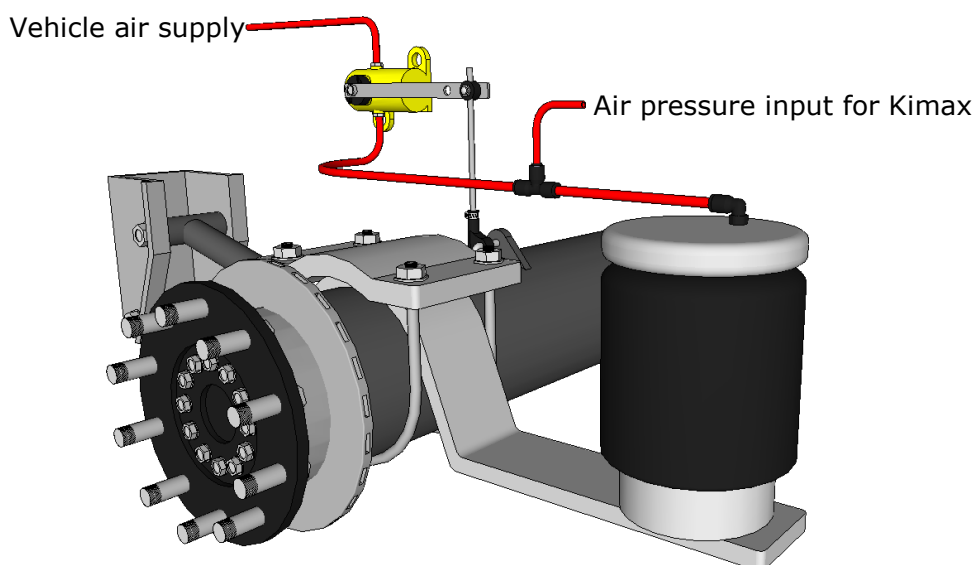

In order to make the Kimax 2 Radio work properly on your vehicle, you need to teach the instrument how to calculate different loads. So before you can rely on your new on-board scale, each axle has to be calibrated after the installation. The calibration is carried out by weighing each axle of the vehicle on a weighing bridge. While your truck is standing on the weighing bridge you must give in the empty weight (LO) and loaded weight (HI), when the vehicle is empty or loaded respectively.

The following diagram shows an example of calibration of an air suspended vehicle with 2 axles. When the vehicle was empty, the weight of the front axle was measured on the weighing bridge to 4,30 tons (LO value for the front axle). Equally the rear axle was measured to 5,70 tons (LO value for the rear axle). These LO values are now entered in the LO menu of

the Kimax 2 Radio. It is crucial to enter the values right away as the pressure in the air suspension system will change when the vehicle is loaded. Now the vehicle needs to be loaded in order to perform the HI calibration. When the vehicle was loaded, the weight of the front axle was measured on the weighing bridge to 7,70 tons (HI value for the front axle). Equally the rear axle was measured to 11,8 tons (HI value for the rear axle). In the same manner the HI values are now entered in the HI menu of the Kimax 2 Radio. Again it is important to enter the values right away, while the pressure in the air suspension system matches the loaded vehicle. Now the Kimax 2 is calibrated.

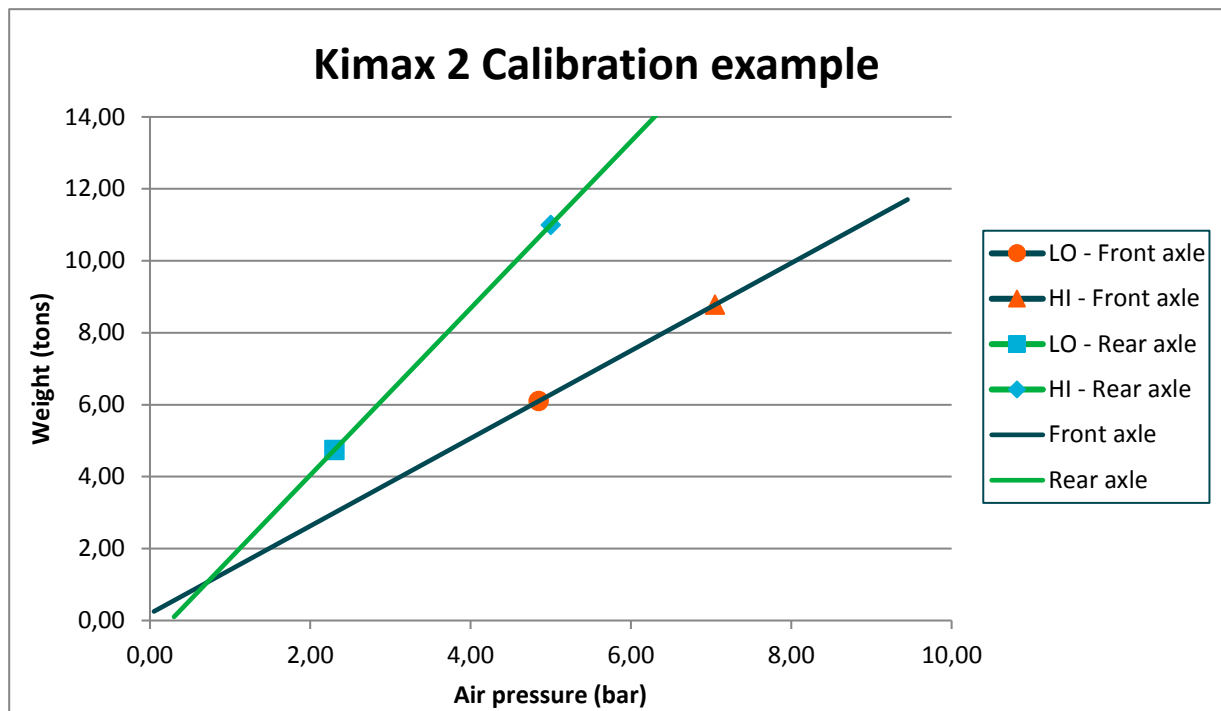

The air pressure is measured on the right and left side of each axle and routed to the Kimax instrument, to obtain the most accurate weighing results under different circumstances.

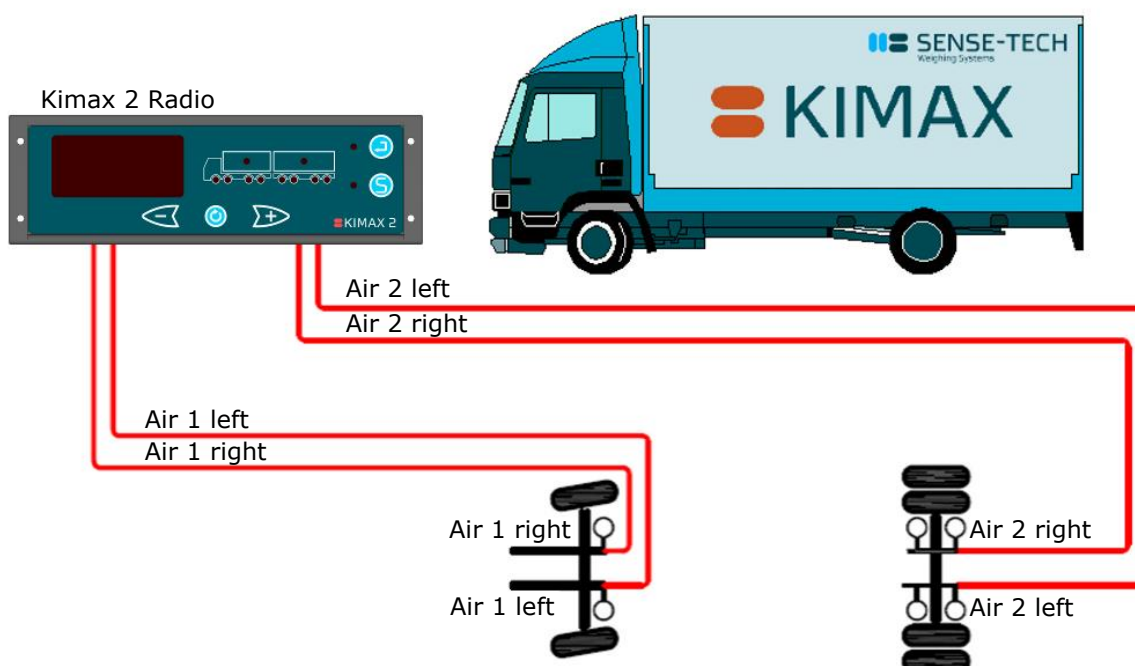

## Daily use



When you switch on your Kimax 2 Radio, it will show the total weight of the entire vehicle in the 3-digit display measured in tons.

The active axle LEDs as well as the load LED are on.

When a trailer is connected to your vehicle, the active axle LEDs and load LED for the trailer is turned on too<sup>1</sup>.

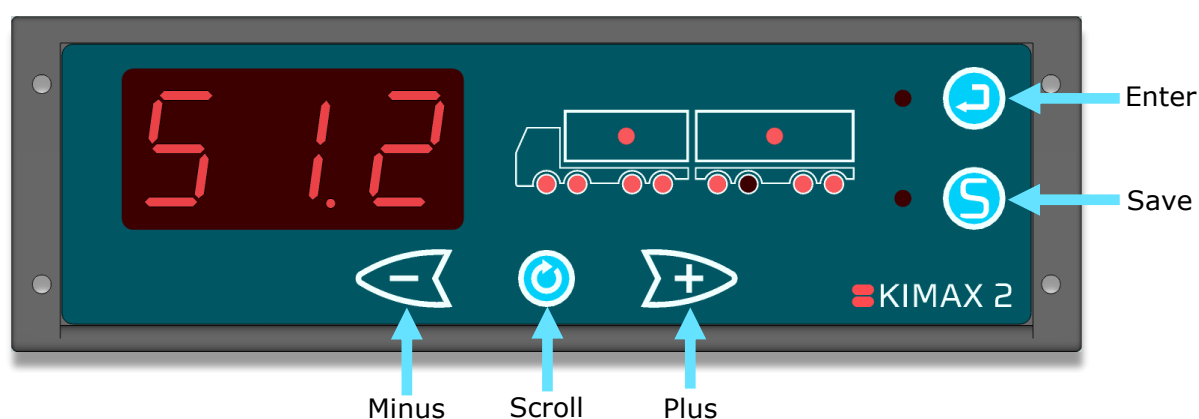
When you disconnect the trailer from your vehicle, the axle and load indications for the trailer disappear after a few seconds, as well as the displayed weight is reduced by the weight of the trailer.



By use of the buttons ,  and , you can display the individual weight of each axle, the load you are carrying and the total weight of your vehicle.

The following pages will give a short walk through the buttons and show you the easy way of reading and printing values from your Kimax 2 Radio. Visit [www.kimax.com](http://www.kimax.com), and navigate to Support and choose Training center. There you can try the Kimax 2 emulators to experience a live test of how you can navigate between the weighing values.

### Turning on the Kimax 2 Radio

When you switch on the power for your Kimax 2 Radio, you read a 3-digit number in the display for about 3 seconds. The number equals the software version of your instrument.

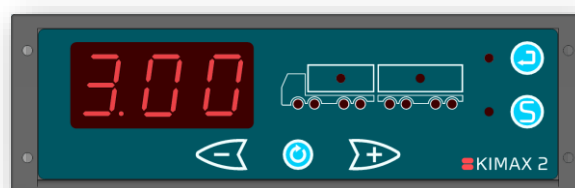

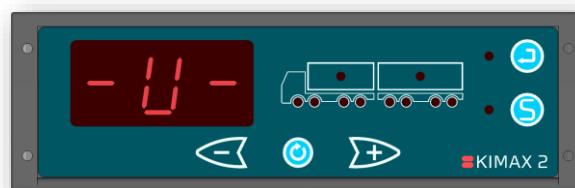

Next read out is an indication of the protection of the setup and calibration of your instrument. The writing **-L-** indicates that the instrument is protected against changing the setup and calibration, while **-U-** means that your unit is unlocked and the calibration and setup can be changed.



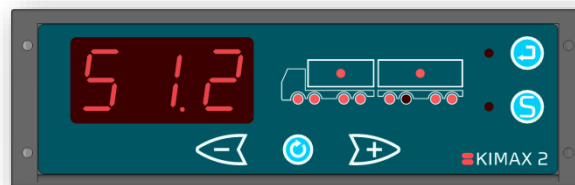

<sup>1</sup> Only if a Kimax 2 Sensor is installed on the connected trailer

Now the instrument automatically starts showing the total weight. (Including the weight from a trailer, if a trailer is connected and have a Kimax 2 Sensor installed).

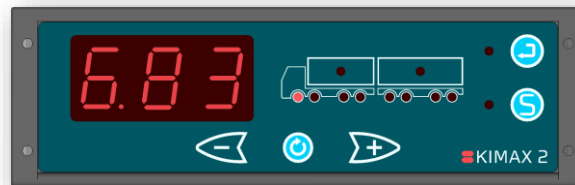

When you press  once, the Kimax 2 Radio displays the actual weight of the first active channel, which in this case is measuring the input from axle #1 and only the assigned axle LED #1 is lit up.



Press  once, and the instrument will show the actual weight of the next active channel. The shown channel is measuring the input from axle #2 and the assigned axle LED #2 is lit up.

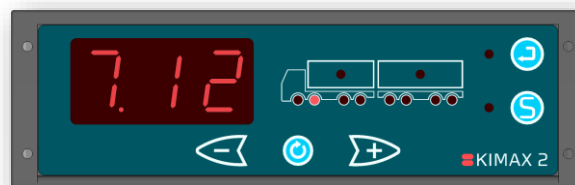

Press  once again, and the instrument will show the actual weight of the next active channel. The shown channel is measuring the input from axle #3 and the assigned axle LED #3 is lit up.

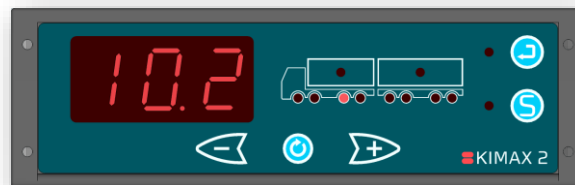

Press  once again, and the instrument will show the actual weight of the next active channel. The shown channel is measuring the input from axle #4 and the assigned axle LED #4 is lit up.

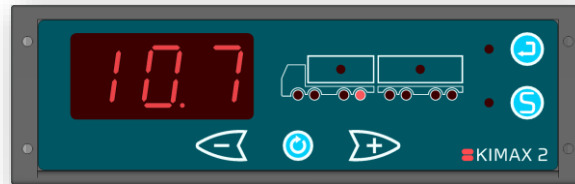

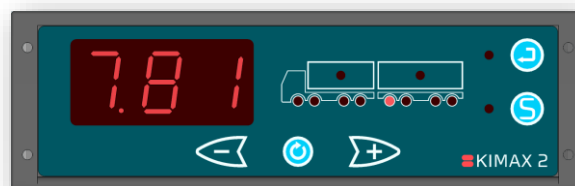

Press  once again, and the instrument will show the actual weight of the next active channel. In this case the shown channel is measuring the input from axle #5, which is the first axle on the trailer and the assigned axle LED #5 is lit up<sup>2</sup>.

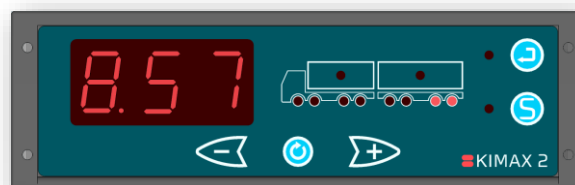

Press  once again, and the instrument will show the actual weight of the next active channel, which is measuring the input from the boogie axle #6 and #7 on the trailer. The assigned axle LED #7 and axle LED #8 are lit up<sup>2</sup>.





Press  once again and the instrument will return to the first active channel or press  and the display will return to the former active channel.

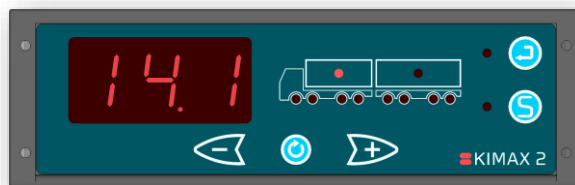

<sup>2</sup> Only if a Kimax 2 Sensor is installed on the trailer. Otherwise the instrument will return to the first active channel.

When you press  in any of the single axle modes, the load of the related vehicle is shown indicated by turning on the load LED.



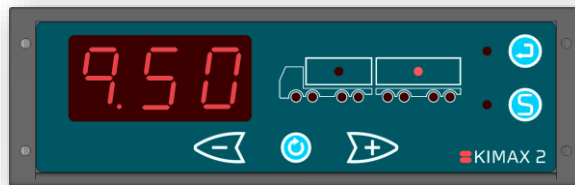

Press  or , to toggle between the load on your vehicle and the load on your trailer.



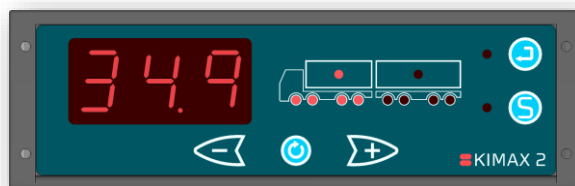

When no trailer is present, pressing  or  will not affect the displayed value.

Press  in any of the load modes and the total weight of the active vehicle is displayed. This mode is displayed by turning on both the load LED and the axle LEDs on the active vehicle.



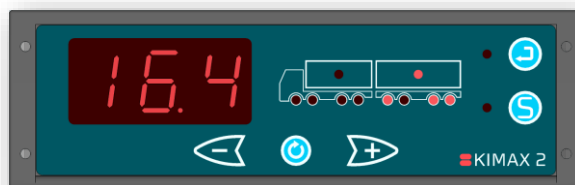

Press  or , to toggle between the total weight of your vehicle and the total weight of your trailer.



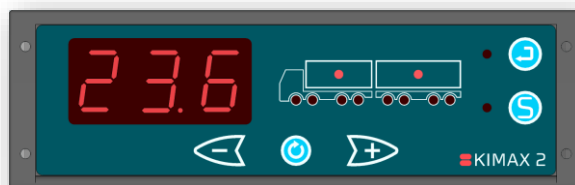

When no trailer is present, pressing  or  will not affect the displayed value.

When you press  in both of the two former total weight modes the entire load on your vehicle + trailer is shown.

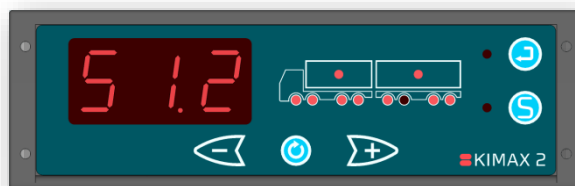

Press  once again to return to the total weight of your vehicle + trailer.



In any of the mentioned display modes above, you can turn your display off by pressing  shortly. Press  shortly once more to turn your display back on.



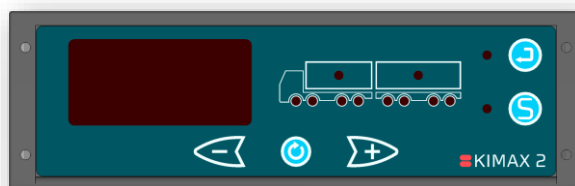

While the display turned off, the alarm outputs A2, A3, A4<sup>3</sup>, the OBC signal and the wireless<sup>4</sup> signal is still active and broadcasted.



<sup>3</sup> Depending on the software version. In some versions A2, A3 and A4 are disabled, when the display is turned off.

<sup>4</sup> There will only be a wireless signal if the Kimax 2 instrument is a model with a transmitter.



When the instrument is showing the total weight<sup>5</sup>, it is possible to enter the Tare mode by pressing . The LED next to  turns on and the value previously shown on the display will be reset to 0,00 tons. When the load changes (positive or negative) the change will be shown in the display (as a positive value). If a printer is connected to the instrument it is possible to get a print out by pressing . When printing from Tare mode the Tare value will be printed as well. Press  once again to leave the Tare mode.

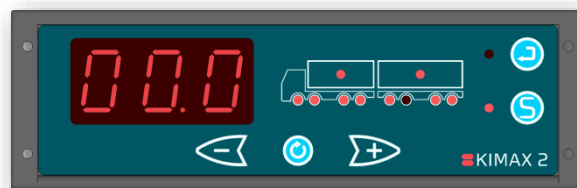

<sup>5</sup> Total weight in this case means, that the instrument is showing the total weight for the truck + trailer if a trailer is connected. Otherwise it is when showing the total weight of the truck.

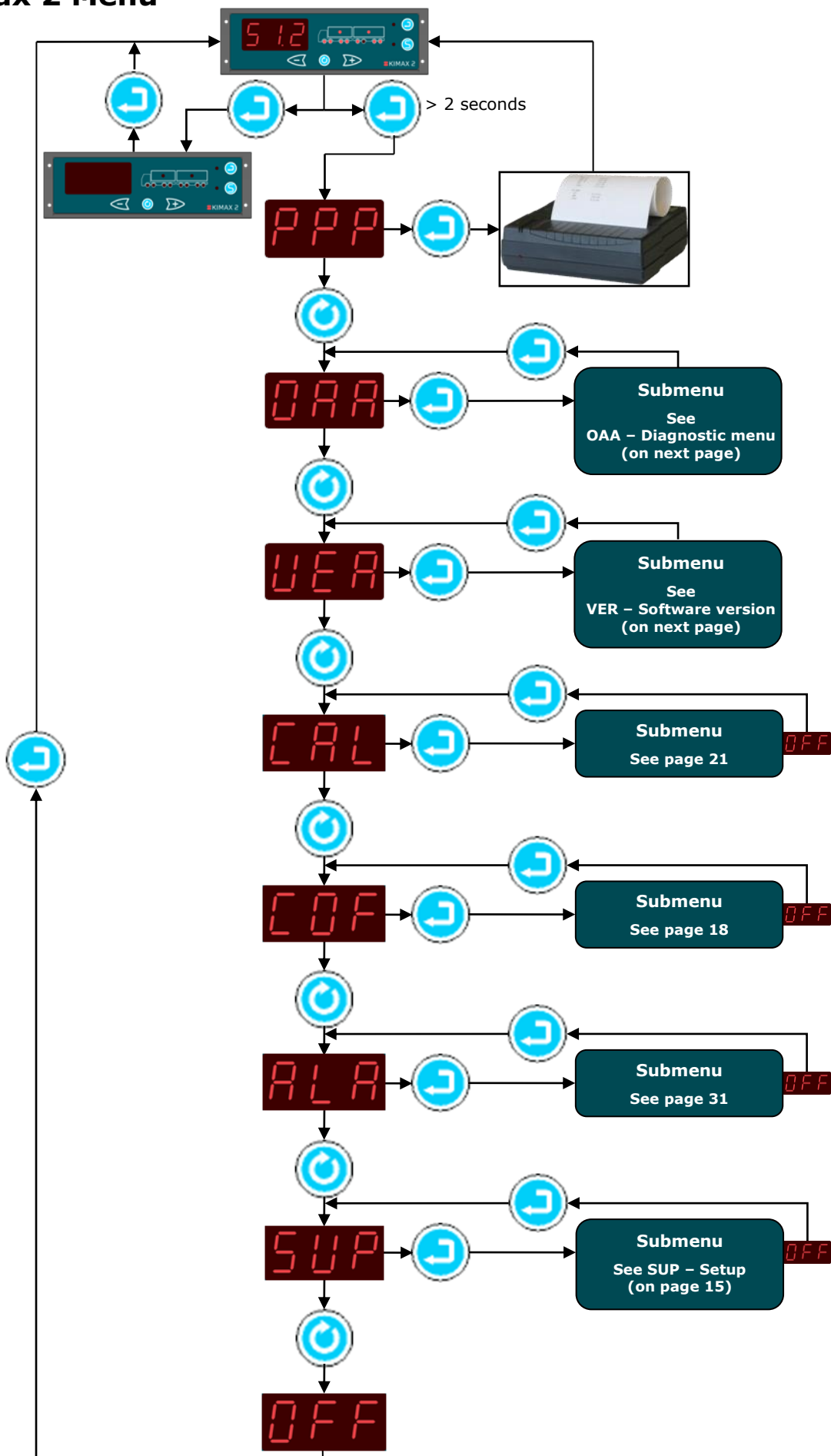

# Kimax 2 Menu



## Entering the Kimax 2 menu

Through an easy to use menu, you will be able to print out the actual weight values of your vehicle on a printer connected to the Kimax 2 system.

Furthermore, you can read some additional setup values on the display, helping you understand how the Kimax 2 weighing system is working.

By pressing  for 2 seconds, you will get access to the Kimax 2 service menu. While you are in the menus, the LED next to  will be turned on.

By pressing , when you are inside the menu, you scroll through the following menus.

When you continue scrolling until the display reads OFF, it is possible to leave the menu by pressing .

### PPP - Print-out

The first position is the printing menu.

Pressing , will take you on to the next menu position called **OAA**.

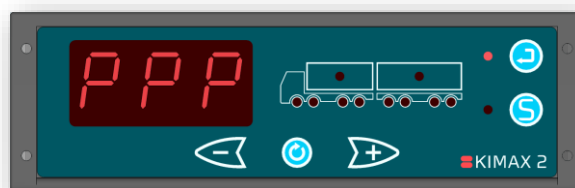

By pressing  you will get a printed copy of your actual load, when a printer is connected to the Kimax 2. Hereafter the Kimax 2 leaves the menu and returns to normal read out.



### OAA - Diagnostic menu

Pressing , will take you on to the next menu position called **VER**.

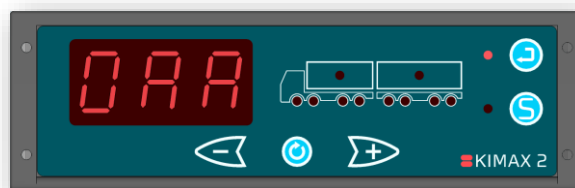

Press  and you will enter the **OAA** menu, where you get a relative value, ranging from 0,00% to 99,9%, displaying the actual sensor value of the first active channel.

You can rotate between the active channels #1 to #8 by pressing . Press  again to return from the **OAA** menu.



### VER - Software version

Pressing , will take you on to the next menu position called **CAL**.

Press  and you will enter the **VER** menu, where the Kimax 2 will show the software version of the current Kimax 2 instrument. By pressing , it is possible to see the software versions of the connected Kimax 2 instruments.

Press  again to return from the **VER** menu.

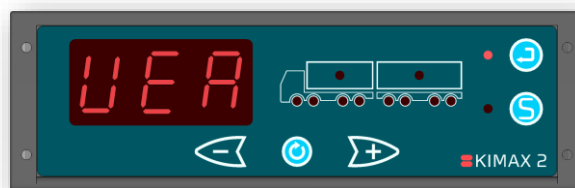

## CAL – Calibration

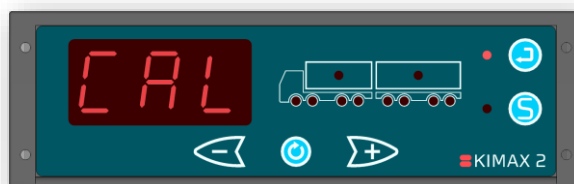

Pressing , will take you on to the next menu position called **COF**.

Press  and you will go to the first position in the calibration submenu called **LO**.



## LO – Empty calibration

Pressing , will take you on to the next calibration submenu position called **HI**.

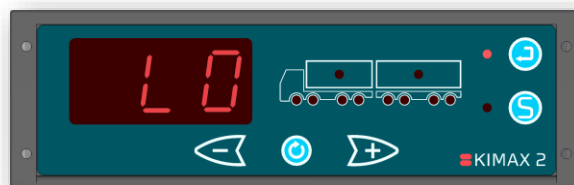

Press  to enter the **LO** calibration submenu and the Kimax 2 will show the stored **LO** - value for the first active axle in the display (0,00 t – 99,9 t). The related axle LED(s) will be on. You can rotate between the active channels by pressing .

Press  again to leave the **LO** calibration submenu.



## HI – Loaded calibration

Pressing , will take you on to the next calibration submenu position called **AdL**.

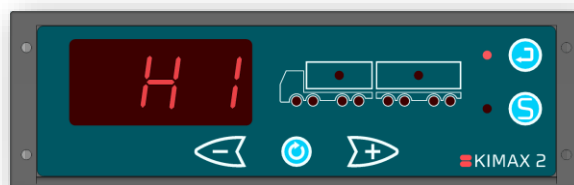

Press  to enter the **HI** calibration submenu and the Kimax 2 will show the stored **HI** - value for the first active axle in the display (0,00 t – 99,9 t). The related axle LED(s) will be on. You can rotate between the active channels by pressing .

Press  again to leave the **HI** calibration submenu.



## AdL – Stored sensor value (at empty calibration)

Pressing , will take you on to the next calibration submenu position called **AdH**.

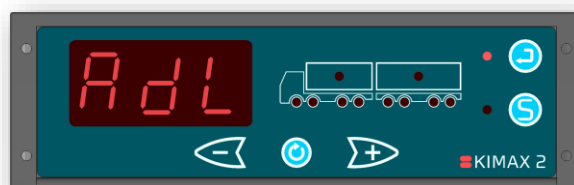

Press  to enter the **AdL** calibration submenu and the Kimax 2 will show the stored **AdL** - value for the first active axle in the display (0,00 % – 99,9 %). The related axle LED(s) will be on. You can rotate between the active channels by pressing .

Press  again to leave the **AdL** calibration submenu.



## AdH – Stored sensor value (at loaded calibration)

Pressing , will take you on to the last calibration submenu position, **OFF**.

Press  to enter the **AdH** calibration submenu and the Kimax 2 will show the stored **AdH** - value for the first active axle in the display (0,00 % – 99,9 %). The related axle LED(s) will be on. You can rotate between the active channels by pressing .

Press  again to leave the **AdH** calibration submenu.

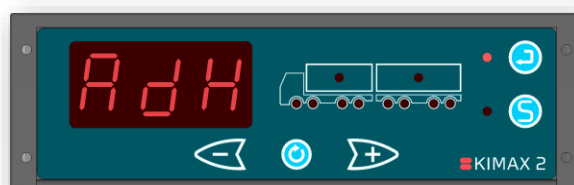

## OFF

Pressing , will take you back to the first calibration submenu position, **LO**.

Press  to leave the calibration submenu and return to **CAL**.

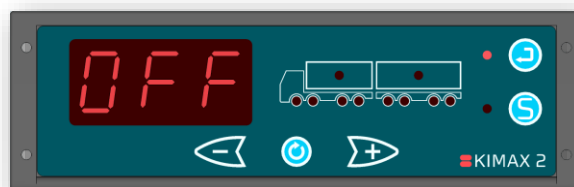

## COF - Configuration

Pressing , will take you on to the next menu position called **ALA**.

Press  and you will go to the first position in the configuration submenu called **CH**.

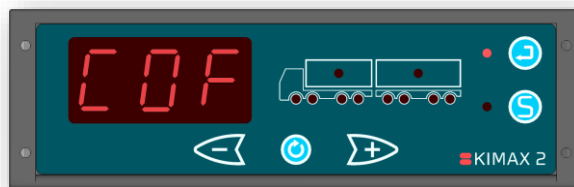

## CH - Configuration

Pressing , will take you on to the next position in the configuration submenu called **HFA**.

Press  and the Kimax 2 displays which axle LEDs are assigned to which input channels.



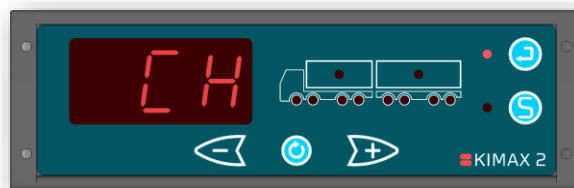

You can rotate between the input channels #1 through #8 by pressing .

Press  again to return from the **CH** configuration submenu.









## HFA - Configuration

Pressing , will take you on to the next position in the configuration submenu called **Id** (if **HFA** setting is set to 0 or 1, otherwise you will go to the last position in the configuration submenu, **OFF**).

Press  and the Kimax 2 displays the **HFA** setting: 0, 1, 2 or 3. Change this setting by pressing either  or  and save the change by pressing . Press  again to return from the **HFA** configuration submenu.

## Id - Configuration<sup>6</sup>

Pressing , will take you on to the last position in the configuration submenu, **OFF**.

Press  and the Kimax 2 displays the **Id** setting: 001—9997. Change this setting by pressing either  or  and save the change by pressing . Press  again to return from the **Id** configuration submenu.

## OFF

Pressing , will take you back to the first configuration submenu position, **CH**.

Press  to leave the submenu and return to **COF**.

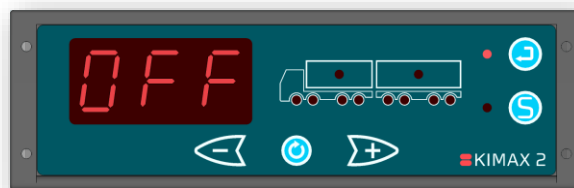
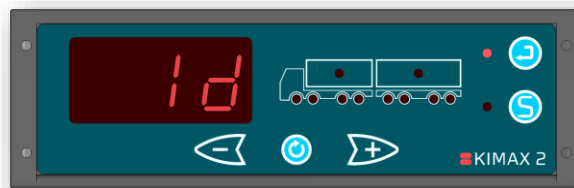
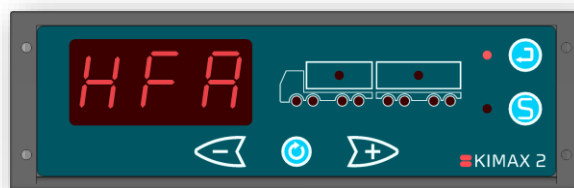

<sup>6</sup> Id menu is only visible if HFA is set to either 0 or 1. (Master instrument)

<sup>7</sup> If the Kimax 2 Radio has a transmitter, make sure the Id setting on the Kimax 2 Radio and Kimax 2 Wireless terminal are similar. If the Kimax 2 Radio doesn't have a transmitter, the Id setting has no function. The Id setting will however be present on a print out from a connected printer.

## ALA – Alarms



Pressing , will take you on to the next menu position called **SUP**.



Press  and you will go to the first alarm submenu called **A1**.



### A1 – Individual Axle Alarm

Pressing , will take you on to the next alarm submenu position called **A2**.

Press  to enter the **A1** alarm submenu and the Kimax 2 will show the stored **A1** - value for the first active channel in the display (0,00 t – 99,9 t). The related axle LED(s) will be on. You can rotate between the active channels by pressing .

By pressing either  or  you can change the value and save the change by pressing  for each individual channel.

If the load exceeds the stored value for the chosen channel the associated axle LED(s) will flash when the Kimax 2 is in run mode.

Press  again to leave the **A1** alarm submenu.

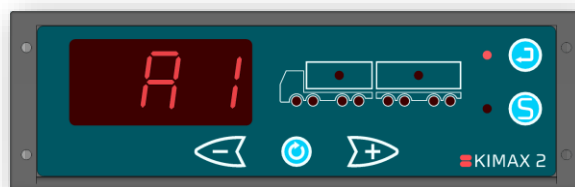



### A2 – External Vehicle Alarm

Pressing , will take you on to the next alarm submenu position called **A3**.

Press  and you will enter the **A2** menu, where the Kimax 2 will show the alarm level for the 1<sup>st</sup> external vehicle alarm of the truck instrument. All the assigned truck LEDs will be on.

By pressing , it is possible to see the alarm level for a connected trailer instrument.

By pressing either  or  you can change the value and save the change by pressing  for each instrument.

Press  again to return from the **A2** menu.

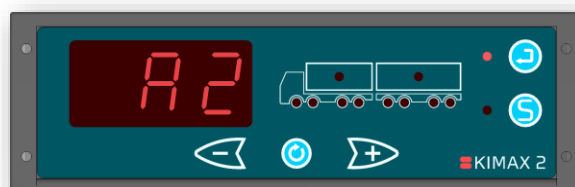

### A3 – External Vehicle Alarm<sup>8</sup>



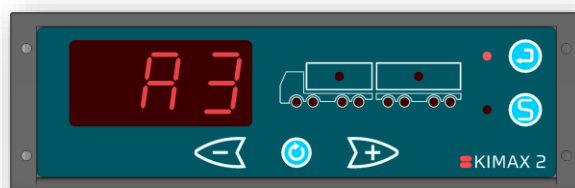

Pressing , will take you on to the next alarm submenu position called **A4**.

Press  and you will enter the **A3** menu, where the Kimax 2 will show the alarm level for the 2<sup>nd</sup> external vehicle alarm of the truck instrument. All the assigned truck LEDs will be on.

By pressing , it is possible to see the alarm level for a connected trailer instrument.





<sup>8</sup> Not available in all versions.



By pressing either  or  you can change the value and save the change by pressing  for each instrument.  
Press  again to return from the **A3** menu.

## A4 – External Vehicle Alarm<sup>9</sup>

Pressing , will take you on to the next alarm submenu position called **OFF**.

Press  and you will enter the **A4** menu, where the Kimax 2 will show the alarm level for the 3<sup>rd</sup> external vehicle alarm of the truck instrument. All the assigned truck LEDs will be on.

By pressing , it is possible to see the alarm level for a connected trailer instrument.

By pressing either  or  you can change the value and save the change by pressing  for each instrument.

Press  again to return from the **A4** menu.

## OFF

Pressing , will take you back to the first submenu position, **A1**.

Press  to leave the submenu and return to **ALA**.

## SUP – Setup

Pressing , will take you on to the last menu position, **OFF**.

Press  shortly and you get access to the **LAN - dA - CLO - SEC - OFF** submenus.

## LAN - Language<sup>10</sup>

Pressing , will take you on to the next submenu position called **dA**.

Press  and the Kimax 2 displays the printer language setting: 1 - 6.

**1** = Danish.



**2** = English.

**3** = German.

**4** = Spanish.

**5** = French.

**6** = Swedish.

Change this setting by pressing either  or  and save it by pressing .

Leave the LAN menu by pressing .

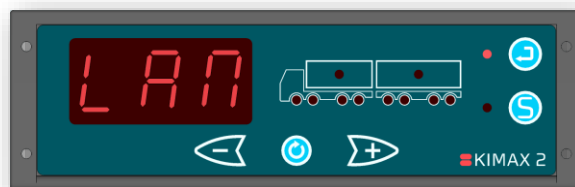
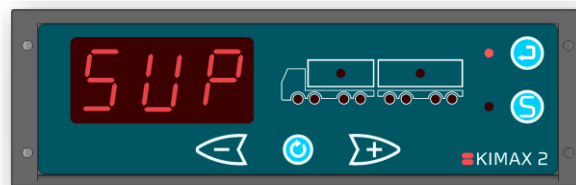
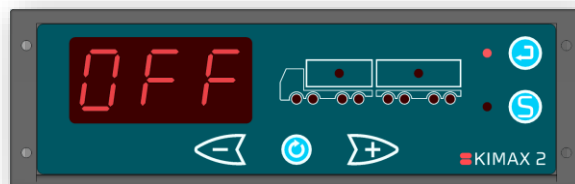
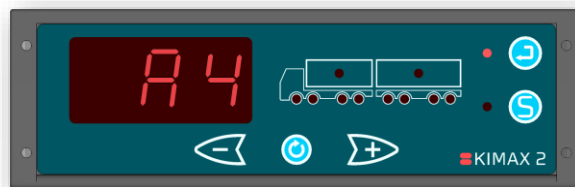



<sup>9</sup> Not available in all versions.

<sup>10</sup> The language setting **only** affects which language is used by an attached printer



## dA – Date<sup>11</sup>

Pressing , will take you on to the next submenu position called **CLO**.

Press  once and the Kimax 2 displays the **date**: 01 - 31.

Press  and the Kimax 2 displays the **month**: 01 - 12.

Press  once more and the Kimax 2 displays the **year**: (2)000 – (2)100.

Change the above settings by pressing either  or  and save it by pressing .

Leave the **dA** menu by pressing .

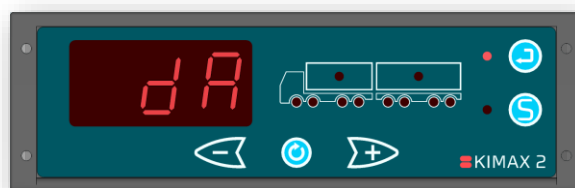





## CLO – Clock<sup>12</sup>

Pressing , will take you on to the next submenu position called **SEC**.

Press  once and the Kimax 2 displays the **hour** setting: 00 - 23.

Press  and the Kimax 2 displays the **minute** setting: 00 - 59.

Change the above settings by pressing either  or  and save it by pressing .

Leave the **CLO** menu by pressing .

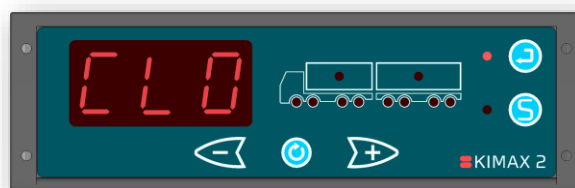



## SEC – Semitrailer configuration

Pressing , will take you on to the last submenu position, **OFF**.

Press  and the Kimax 2 displays the **SEC** setting: 0 or 1.

**0** = Truck / Trailer combination.

**1** = Semi Truck / Semi Trailer combination<sup>13</sup>.

Change this setting by pressing either  or  and save the change by pressing .

Press  again to return from the **SEC** submenu.

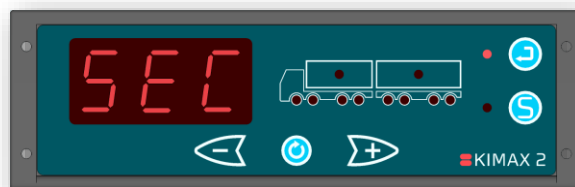

## OFF

Pressing , will take you back to the first submenu position, **LAN**.

Press  to leave the submenu and return to **SUP**.

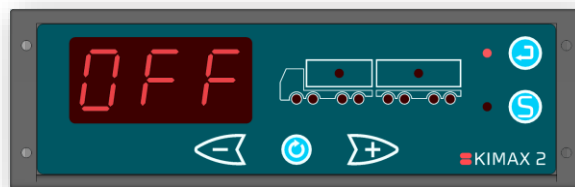

<sup>11</sup> The "Date" stored in this setting affects the printed date on a print out from an attached printer.

<sup>12</sup> The "Clock" stored in this setting affects the printed time on a print out from an attached printer.

<sup>13</sup> If SEC is set to 1, there will only be three weighing display modes in the outer menu. It won't be possible to scroll between truck and trailer when showing payload and total weight.



## OFF - leave Menu

Pressing , will take you back to the first menu position, **PPP**.

Press  to leave the menu when you read OFF in the display.

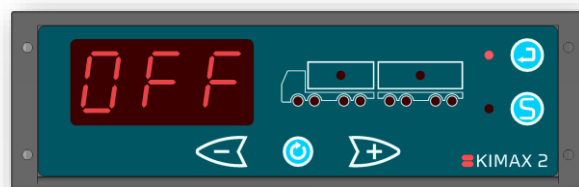

## Configuration

The configuration is a onetime customization of your Kimax 2 instrument, which adapts it to fit your vehicle. When a Kimax 2 instrument leaves Sense-Tech Weighing Systems ApS, it is pre-configured to fit your vehicle, based upon the information given to Sense-Tech Weighing Systems ApS, when the order was placed. However if the Kimax 2 instrument unexpectedly needs additional configuration, the following pages describes how to calibrate a Kimax 2 instrument. Visit [www.kimax.com](http://www.kimax.com) and navigate to the Support section and choose Training Center. Here it is possible to see some animations showing how to configure a Kimax 2 Radio.

## Communication

A Kimax 2 instrument needs to be taught where it is placed in order to make the communication between more instrument function properly.

Through the **HFA** menu the Kimax 2 instrument can be set up to be either a Master or a Slave instrument. Since the Kimax 2 Radio is intended for use inside the cabin of the truck it needs to be a Master instrument. You can set up your Kimax 2 Radio to be either a Master instrument with or without sensors. If it is chosen to use a Kimax 2 Radio as a MUS<sup>14</sup>, it needs to be connected to a Kimax 2 Sensor (like in scenario 2 below) in order to measure the axle load of a truck.

Instrument type	Master/Slave	HFA setting
Kimax 2 Radio	MUS (Master without sensors)	HFA = 0
Kimax 2 Radio	MMS (Master with sensors)	HFA = 1
Kimax 2 Sensor	SL1 (Slave placed on truck)	HFA = 2
Kimax 2 Sensor	SL2 (Slave placed on trailer)	HFA = 3

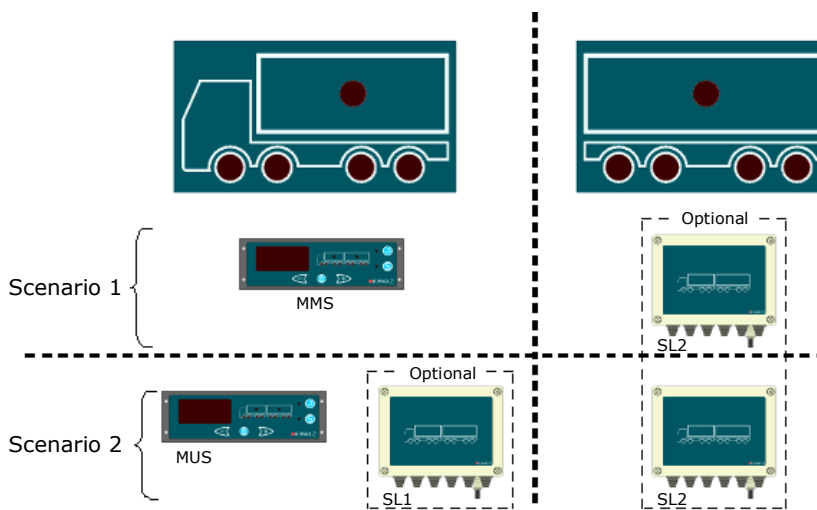

**Once you have made the communication setup you are ready to customize the instrument(s) to your vehicle. This has to be done in order to make the system work properly.**

<sup>14</sup> Master instrument without sensors.

## Configuration menu

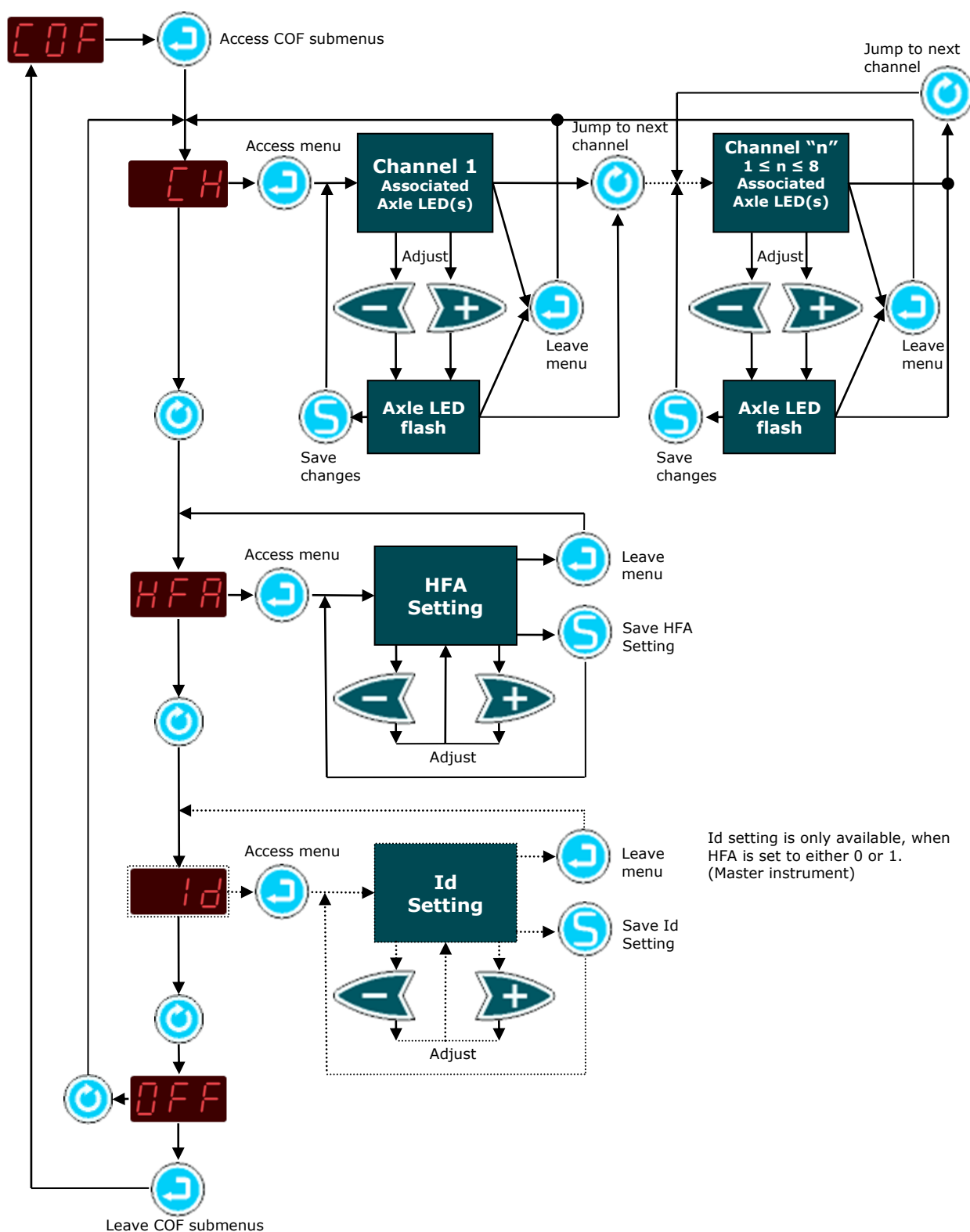

## How to set up HFA

Enter the **HFA**-menu to make sure the setting is correct otherwise change it.

Enter the menu and change the setting, remember to save the setting by pressing .



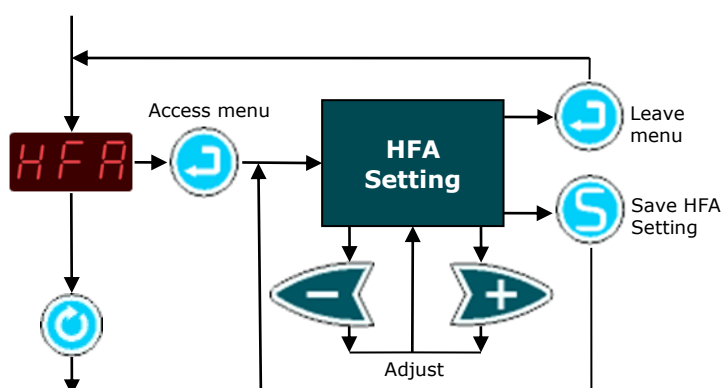

When you have finished setting up these settings **you must continue to the next part "Setting up the Axle-LEDs"**



## Setting up the Axle-LEDs

Through the **COF** menu you can assign certain axle LEDs to each of the 8 analogue channels (4 channels on a master instrument + 4 channels on a slave instrument).

Enter the **CH**-menu to assign LED's to the individual input channels:

When an LED is flashing you can change its setting by pressing . To make an LED flash press either  or . Change to the next input channel by pressing .

You can assign several LEDs to one input channel but you cannot assign a specific LED to more than one input channel.

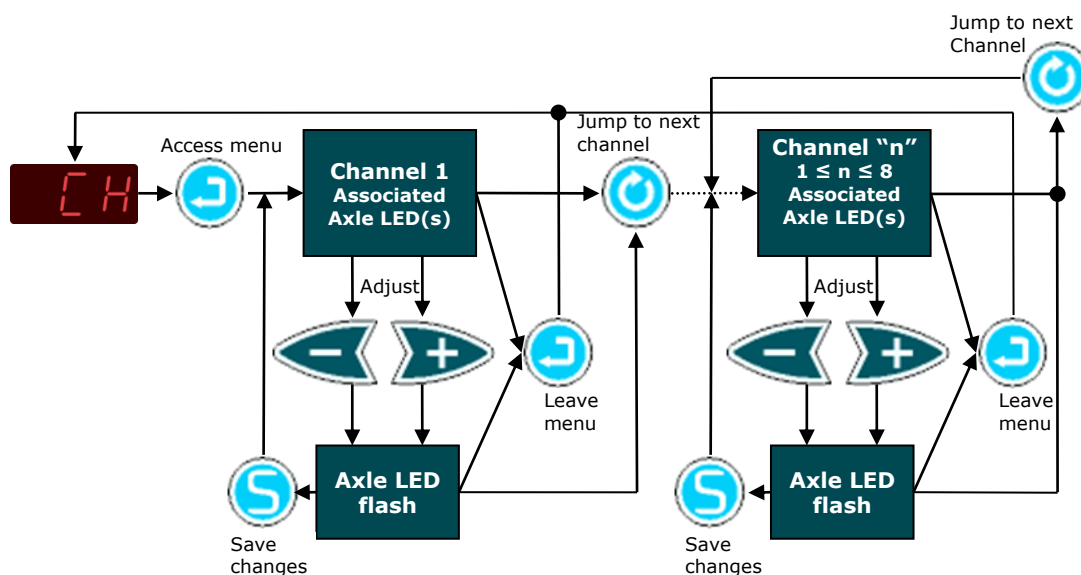







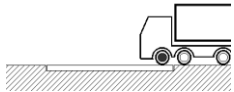

## Calibration

Once the installation and setup of your Kimax instrument is done, it is time to calibrate the instrument. This calibration is linking an actual *unloaded* weight of an axle together with a **LO** reading of this axle, - and linking a *loaded* weight of an axle together with a **HI** reading of this axle. The **LO** and **HI** calibration has to be carried out for all axles or axle groups. The actual weight of each axle on your vehicle has to be measured on a weighing bridge.

### LO weighing

For calibration of the **LO** values on each individual axle, you have to weigh an unloaded vehicle in the following positions on a weighing bridge, showed in the table. The table is showing an example for a 4-axle vehicle.

LO	 Position Axle #1	 Position Axle #1+2	 Position Axle #1+2+3	 Position Axle #1+2+3+4
Readings on Weighing bridge	<b>4,62 T</b>	<b>8,44 T</b>	<b>12,64 T</b>	<b>15,36 T</b>
 Axle 1	Axle 1: <b>4,62 T</b> <small>Axle 1 LO value Axle 1 = Weighing bridge</small>	Axle 1: <b>4,62 T</b> <small>Repeat the LO weight value for axle 1</small>	Axle 1: <b>4,62 T</b> <small>Repeat the LO weight value for axle 1</small>	Axle 1: <b>4,62 T</b> <small>Repeat the LO weight value for axle 1</small>
 Axle 2		Axle 2: <b>3,82 T</b> <small>Axle 2 LO value. Find the LO value for Axle 2 Axle 2 = (Weighing bridge Axle #1+2) - Axle 1</small>	Axle 2: <b>3,82 T</b> <small>Repeat the LO weight value for axle 2</small>	Axle 2: <b>3,82 T</b> <small>Repeat the LO weight value for axle 2</small>
 Axle 3			Axle 3: <b>4,20 T</b> <small>Axle 3 LO value. Find the LO value for Axle 3: Axle 3 = (Weighing bridge axle #1+2+3) - (Axle 1 + Axle 2)</small>	Axle 3: <b>4,20 T</b> <small>Repeat the LO weight value for axle 3</small>
 Axle 4				Axle 4: <b>2,72 T</b> <small>Axle 4 LO value. Find the LO value for Axle 4: Axle 4 = (Weighing bridge axle #1+2+3+4) - (Axle 1 + Axle 2 + Axle 3)</small>

**Important:** The measured values for the axles must be given in right away to the Kimax instrument while the vehicle is carrying the actual measured weight and is parked on an even surface without any brakes active.

Visit [www.kimax.com](http://www.kimax.com) and navigate to the Support section and choose Training Center. Here it is possible to see some animations showing how to calibrate a Kimax 2 Radio.

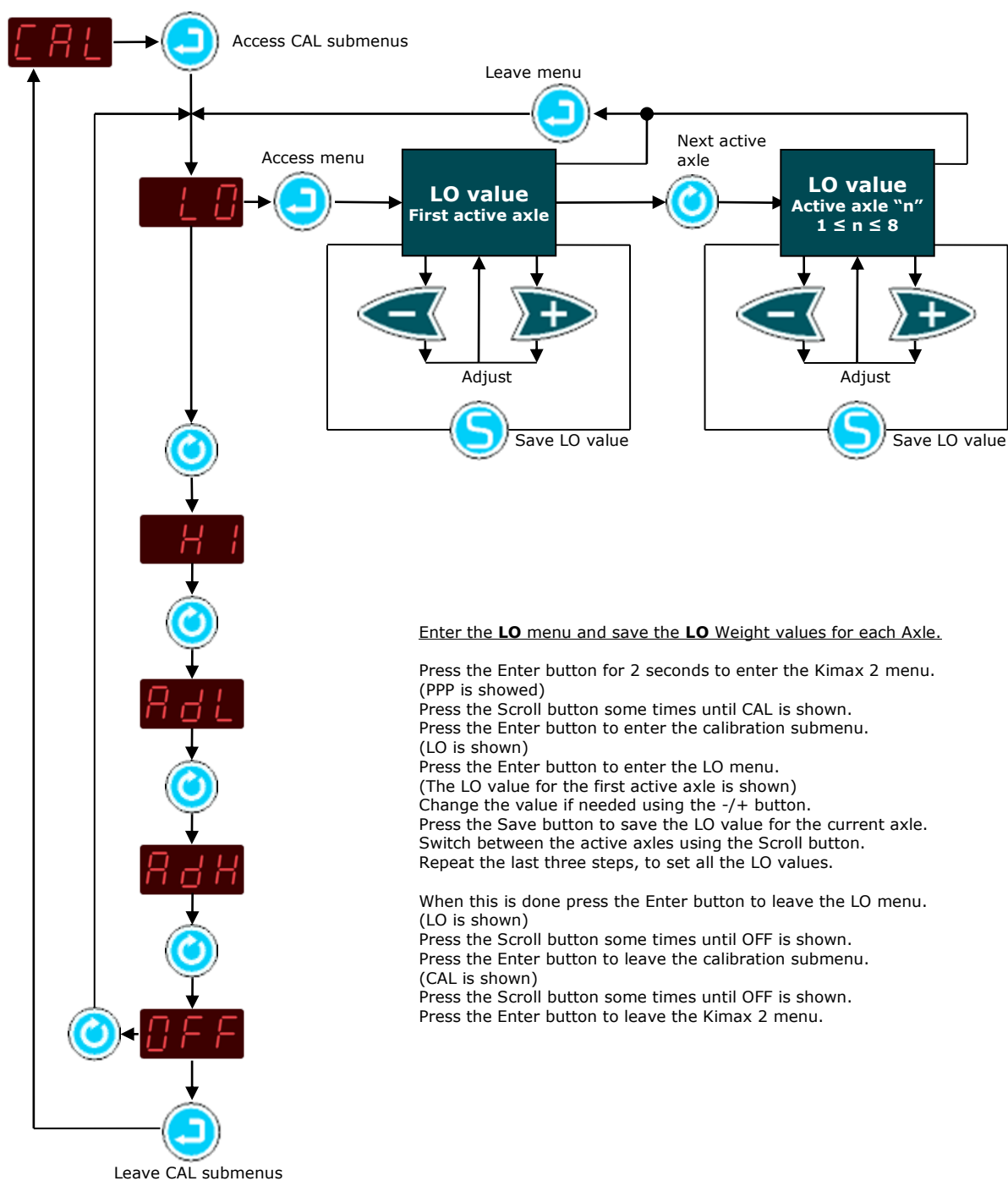







Enter the **LO** menu and save the **LO** Weight values for each Axle.

Press the Enter button for 2 seconds to enter the Kimax 2 menu.  
(PPP is showed)  
Press the Scroll button some times until CAL is shown.  
Press the Enter button to enter the calibration submenu.  
(LO is shown)  
Press the Enter button to enter the LO menu.  
(The LO value for the first active axle is shown)  
Change the value if needed using the -/+ button.  
Press the Save button to save the LO value for the current axle.  
Switch between the active axles using the Scroll button.  
Repeat the last three steps, to set all the LO values.

When this is done press the Enter button to leave the LO menu.  
(LO is shown)  
Press the Scroll button some times until OFF is shown.  
Press the Enter button to leave the calibration submenu.  
(CAL is shown)  
Press the Scroll button some times until OFF is shown.  
Press the Enter button to leave the Kimax 2 menu.

## HI weighing

For calibration of the **HI** values on each individual axle, you have to weigh a loaded vehicle in the following positions on a weighing bridge, showed in the table. The table is showing a example for a 4 axle vehicle.

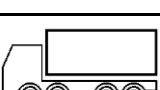
HI	 Position Axle #1	 Position Axle #1+2	 Position Axle #1+2+3	 Position Axle #1+2+3+4
Readings on Weighing bridge	<b>6,14 T</b>	<b>11,54 T</b>	<b>22,44 T</b>	<b>31,78 T</b>
 Axle 1	Axle 1: <b>6,14 T</b> <small>Axle 1 HI value Axle 1 = Weighing bridge</small>	Axle 1: <b>6,14 T</b> <small>Repeat the HI weight value for axle 1</small>	Axle 1: <b>6,14 T</b> <small>Repeat the HI weight value for axle 1</small>	Axle 1: <b>6,14 T</b> <small>Repeat the HI weight value for axle 1</small>
 Axle 2		Axle 2: <b>5,40 T</b> <small>Axle 2 HI value. Find the HI value for Axle 2 Axle 2 = (Weighing bridge Axle #1+2) - Axle 1</small>	Axle 2: <b>5,40 T</b> <small>Repeat the HI weight value for axle 2</small>	Axle 2: <b>5,40 T</b> <small>Repeat the HI weight value for axle 2</small>
 Axle 3			Axle 3: <b>10,90 T</b> <small>Axle 3 HI value. Find the HI value for Axle 3: Axle 3 = (Weighing bridge axle #1+2+3) - (Axle 1 + Axle 2)</small>	Axle 3: <b>10,90 T</b> <small>Repeat the HI weight value for axle 3</small>
 Axle 4				Axle 4: <b>9,34 T</b> <small>Axle 4 HI value. Find the HI value for Axle 4: Axle 4 = (Weighing bridge axle #1+2+3+4) - (Axle 1 + Axle 2 + Axle 3)</small>

**Important:** The measured values for the axles must be given in right away to the Kimax instrument while the vehicle is carrying the actual measured weight and is parked on an even surface without any brakes active.

Visit [www.kimax.com](http://www.kimax.com) and navigate to the Support section and choose Training Center. Here it is possible to see some animations showing how to calibrate a Kimax 2 Radio.

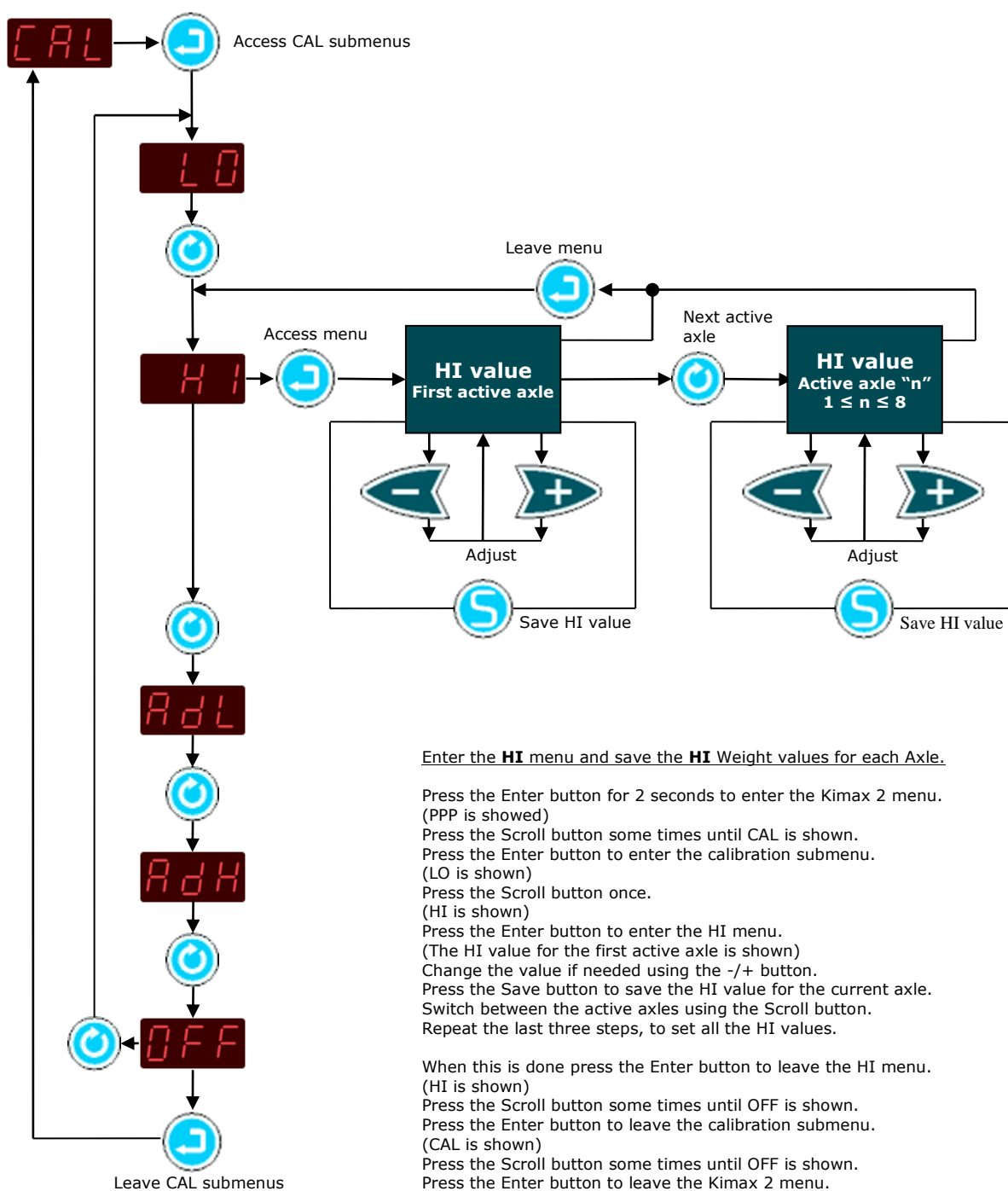



## Protecting your setup and calibration



When the setup, configuration and calibration is done, the settings and values can be protected by activating a software lock on the Kimax 2 Radio.

In the locked position, you are able to read all measured weighing values on your Kimax 2 instrument. Furthermore, you can read the values in the service menus. However, you are not able to change the setup, configuration or calibration by accident.

The software lock is not 'hacker' proof protection, you can easily (decide to) unlock your instrument in order to modify the calibration.

### Locking Kimax 2 Radio

The factory setting is unlocked when you get a new instrument, you read a -U- when you power your instrument up.

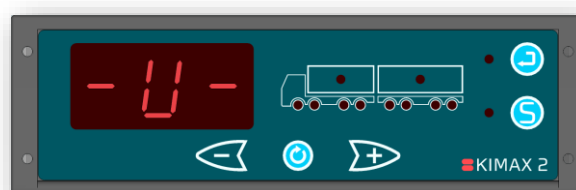

After the setup, configuration and calibration is done you can lock your Kimax 2 Radio by powering up the instrument once again while you press  and .



### Unlocking Kimax 2 Radio

When you decide to recalibrate your system, you need to unlock the Kimax 2 Radio.

A locked instrument is displayed as a -L- when you power it up.

Pressing both  and  while you are powering the instrument up once again will unlock the menus, and you will have access to all setup, configuration and calibration menus again.

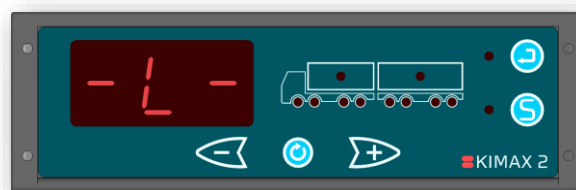

You can lock and unlock your Kimax instrument as often as you like.

The Kimax 2 Radio can be delivered in a special version, where the instrument is protected against changes made with the buttons. This type of instrument can only be configured and calibrated through the Kimax 2 Terminal. To learn more about the Kimax 2 Terminal please visit [www.kimax.com](http://www.kimax.com).

The Kimax 2 instrument is a reliable instrument, which shows the real weight of your vehicle when it is properly calibrated. However, it is your responsibility to maintain the calibration of your instrument. Sense-tech Weighing Systems ApS do not in any case take over the responsibility for the accuracy of your calibration.

## Electrical installation

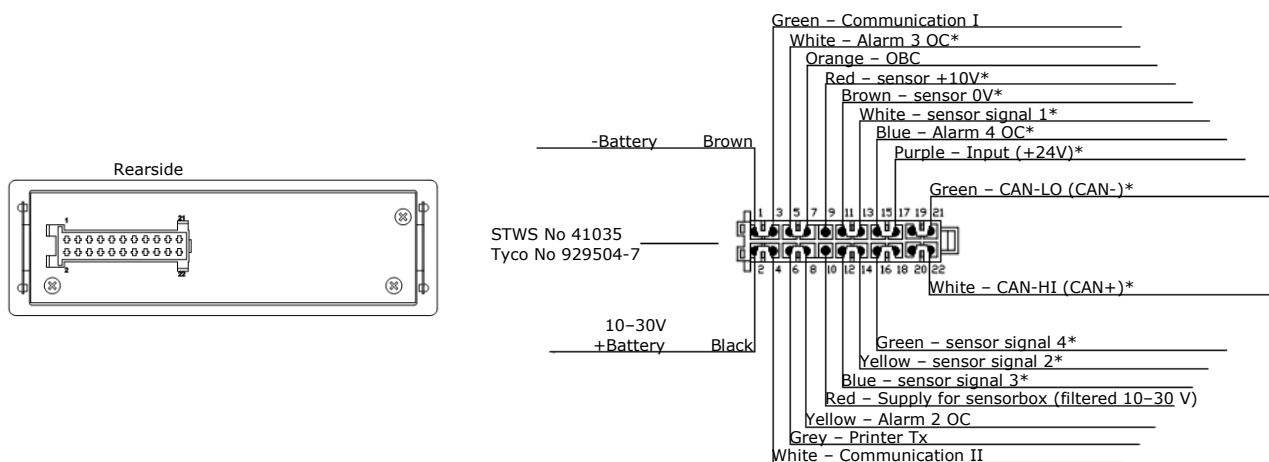

The connections above marked with '\*' are only present if the connection is required by the part number for a given instrument. This example is for a fully featured device.

### Electrical connection

Always disconnect the battery before you perform any installation work on the system of the vehicle.

Do not route the cables next to ignition cables or other cables carrying large currents.

Make sure that the cables are not exposed to tensile or shearing forces. Protect the cables with rubber grommets if you route the cables through holes.

For connecting cables use crimp connectors or another approved method. Avoid short-circuiting the system by faulty connections or squeezed cables.

Fasten the cables at suitable intervals.

Make sure all Kimax 2 instruments are protected by use of fuses in supply cables.

### Basic installation

When you use your Kimax 2 Radio instrument on a single vehicle, you only need to connect the brown wire from pin 1 in the cable set to the chassis (- supply) and the black wire from pin 2 to +24 V through a switch (ignition) and a fuse and you are done.

Unused wires in the cable set are kept insulated from the chassis and any other conducting circuits.

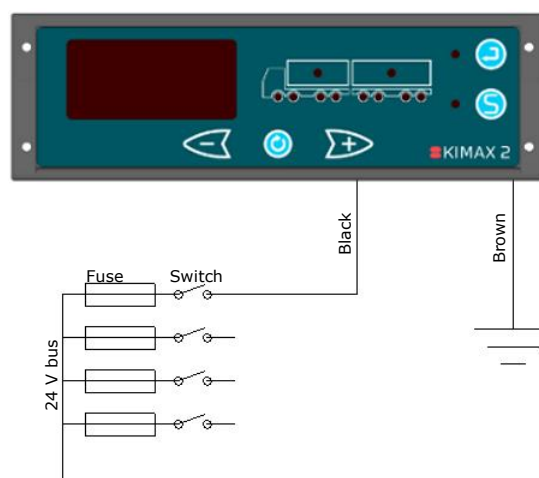

## Standard installation truck–trailer

### Kimax 2 in the cabin:

In a standard truck and trailer installation, the brown wire is connected to the chassis (- supply) and the black wire to +24 V through switch and fuse.

The communication circuit is established by connecting the white wire to the chassis together with the brown wire and by routing the red and green wire as a "new" wire from the truck to the trailer.

This "new" wire is conducting both the supply and communication for the sensor on the trailer. The "new" supply through the red wire, has a limited capacity of 200 mA and must not be used for anything else than Kimax 2 Sensor boxes.

Unused wires in the cable set are kept insulated from the chassis and any other conducting circuits.

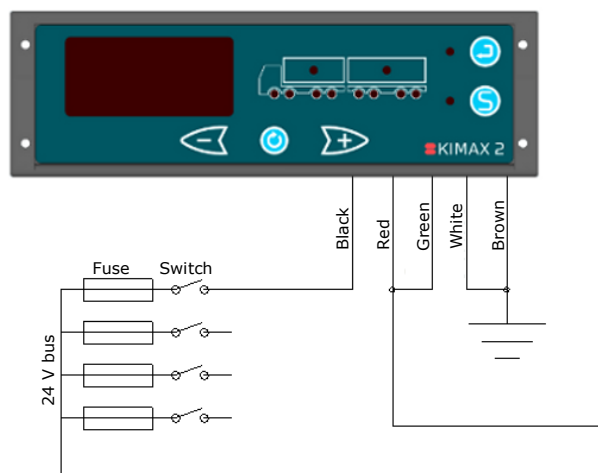

### Kimax 2 on the trailer:

In a standard truck and trailer installation the brown wire is connected to the chassis (- supply) and the gray and green wire to the "new" +24 V.

The communication circuit is established by connecting the white wire to the chassis together with the brown wire and by routing the grey and green wire as a "new" wire from the trailer to the truck.

This "new" wire is conducting both the supply and communication for the sensor on the trailer. The "new" supply through the red wire, has a limited capacity of 200 mA and must not be used for anything thing else than Kimax 2 Sensor boxes.

Unused wires in the cable set are kept insulated from the chassis and any other conducting circuits.

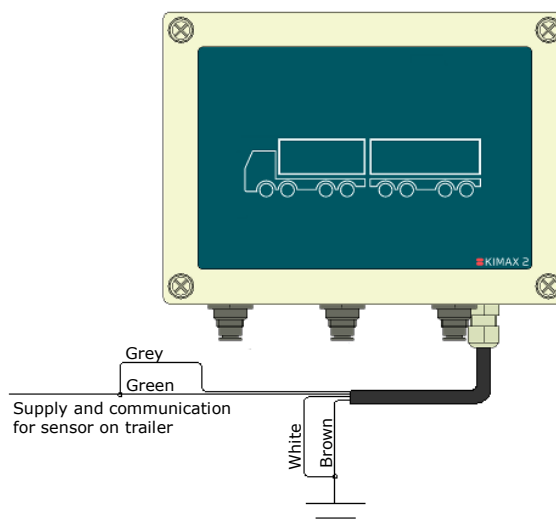

## Getting your system to work:

When you have connected your Kimax 2 Radio and your Kimax 2 Sensor to the electrical system on your vehicle, you need to go to page 18 of this manual for instruction on setting up the communication between Kimax 2 Radio and Kimax 2 Sensor and learn how to customize the Kimax 2 system to fit exactly to your vehicle.

When you have finished the setup of your system, you need to go to page 21 for instructions on how to calibrate the Kimax 2 system.

When you have finished the calibration of your Kimax 2 system, you can go to page 25 to learn how to protect your setup, configuration and calibration.

The Kimax 2 Radio is calibrated together with the bellows (on air suspended vehicles) and the actual weight of the truck.

The Kimax 2 Sensor on the trailer is calibrated together with the bellows (on air suspended vehicles) and the actual weight of the trailer.

In this way, you can swap from one trailer to another trailer and you still can read the actual weight of the entire vehicle on the Kimax 2 Radio (both trailers have to be equipped with a Kimax 2 Sensor).

Some CAN-bus systems are very sensitive and respond immediately when you load circuits with additional power consumption. In these cases, we recommend the standard truck and trailer installation. The power consumption of one Kimax 2 equals the consumption of a 3 W lamp on a 24 Volt system.

## Serial outputs

### OBC serial output

The Kimax 2 Radio panel offers you an RS-232 serial output, which is transmitting the measured weight values. The string of data is broadcasted every 3 second and can be picked up by a GPRS unit e.g. a FM 300 unit.

The OBC serial output can be tested by setting up a "HyperTerminal" on your laptop with the below parameters and you can read the broadcasted values as numeric characters.

Baudrate 9.600  
Data bits 8  
Parity N  
Stopbit 1  
Flowcontrol N

You need to set up your GPRS or FM300 to receive the above parameters too.

In order to retransmit the Kimax 2 values through your GPRS unit, or receive the data in an FM300, you can set up a mask: "UUUUww .... SSS" framing 12 x 5 characters.

When you want to retransmit the total weight of the truck and the trailer, you need to pick up the characters 51, 52, 53 and 54 for the truck and digit 56, 57, 58 and 59 for the trailer.

### Protocol:

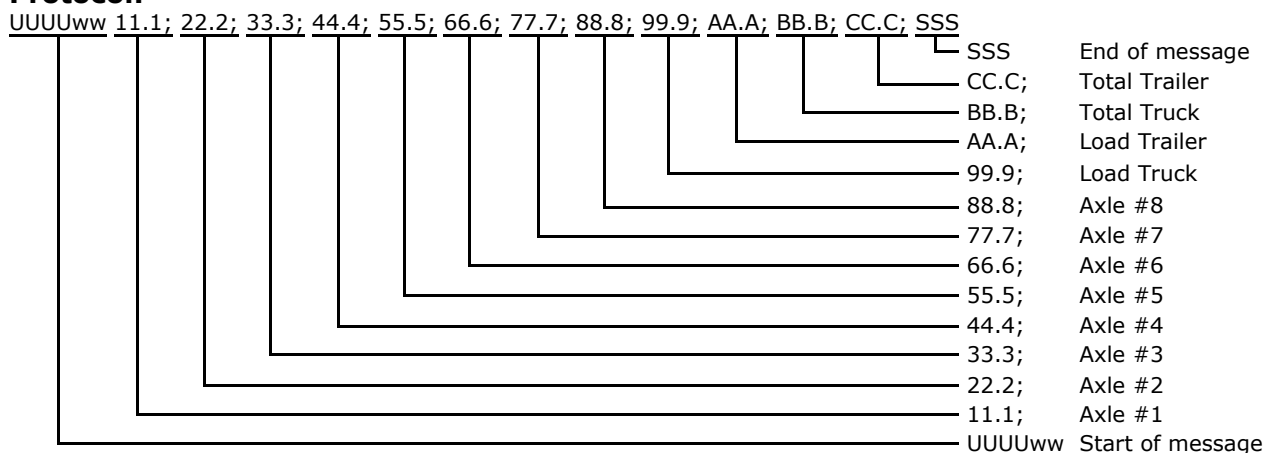

### Connection diagram for On Board Computer signals:

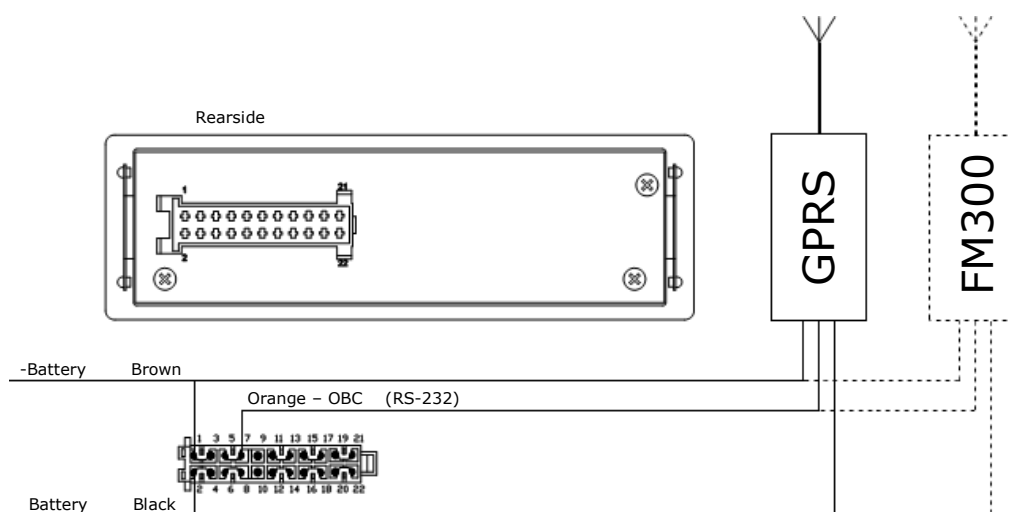

## Printer serial output

The Kimax 2 Radio panel offers you an RS-232 serial output, for printers.

The string of data is broadcasted when the printer function is activated in the menu.

The printer output can be tested by setting up a "HyperTerminal" on your laptop with the below parameters,

Baudrate 4.800  
Data bits 8  
Parity N  
Stopbit 1  
Flowcontrol N

and you can read the broadcasted values as numeric characters.

You need to set up your printer for receiving the above parameters too.

The most common printers with a serial input can be used with Kimax 2.

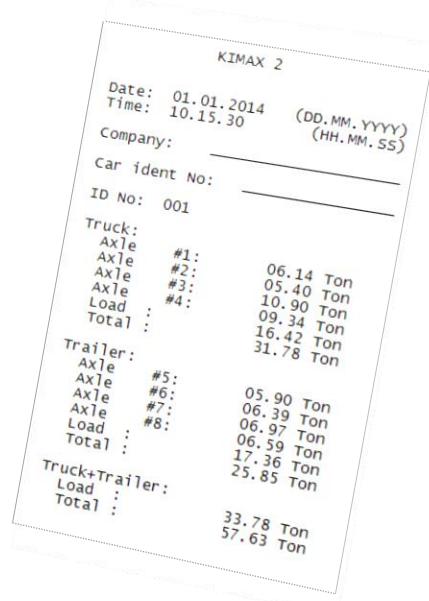

## Connection diagram for serial printer:

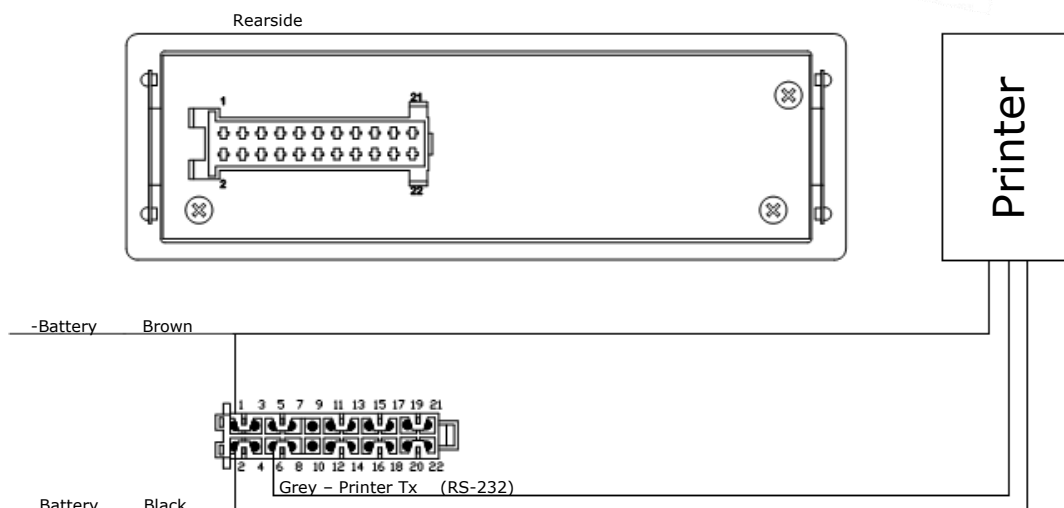

## Kimax 2 Terminal

The possibility of controlling the Kimax 2 Radio in a visual environment exists in form of the Kimax 2 Terminal. By using the Kimax 2 Terminal it is possible to monitor and setup your Kimax instrument. Find out more about the Kimax 2 Terminal by visiting [www.kimax.com](http://www.kimax.com) or contact your local Kimax distributor or Sense-Tech Weighing Systems ApS.



## Alarms

Kimax 2 offers you two different kinds of alarm levels.

**A1** is an individual alarm level for each input channel. When the weight of one or more channels exceeds their stored A1 levels, the associated axle LEDs will start flashing.

**A2**, **A3** and **A4<sup>15</sup>** are external vehicle alarms. When the weight of the vehicle exceeds the stored A2, A3 or A4 level, the output on the respective alarm wire (A2 = yellow wire, A3 = white wire and A4 = blue wire) is switched to ground through a NPN open collector output.

The A2, A3 and A4 outputs have 10 K pull up resistors and are protected by diodes. The load of the A2, A3 and A4 outputs are limited to 200 mA DC.

Typical external alarms are warning lamps mounted in such a way that they are visible from outside the vehicle. You will need a lamp on the truck and a lamp on the trailer.

### Connection diagram for external alarms and DTCO:

The A2, A3 and A4 alarm outputs can be connected to a DTCO to log when and for how long you exceed the A2, A3 and A4 level.

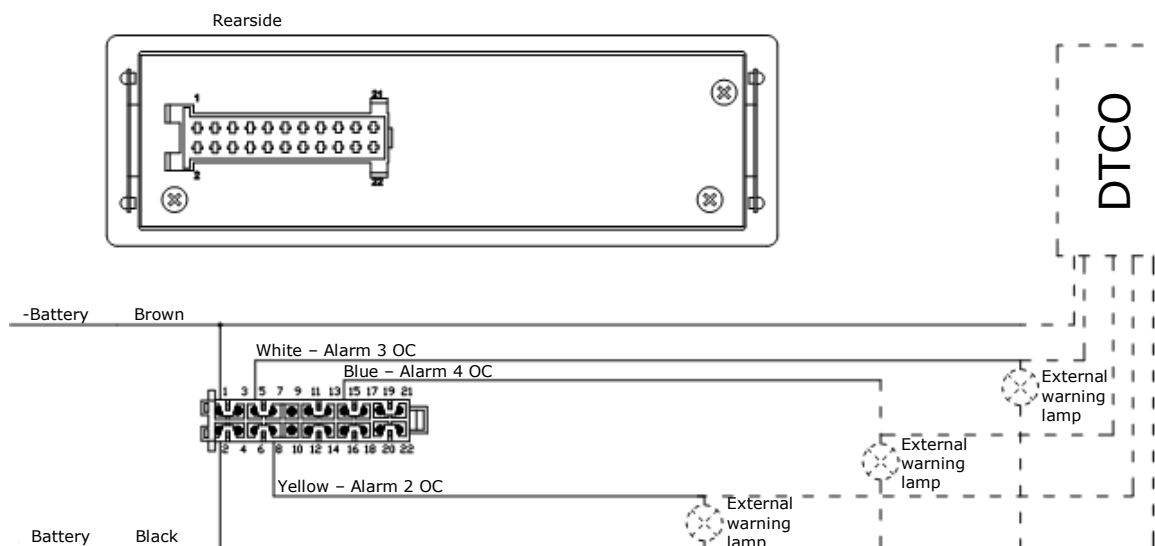

<sup>15</sup> A3 and A4 are only present if it is required by the part number in question.

## Sensor installation

### Air sensor installation

#### Connection of compressed air.

Before you carry out any installation work related to the air suspension, make sure that the suspension has been brought to the lowest possible position and all compressed air are released.

It is important to install the hoses in such a way that they are not affected by other components. The hoses must be fixed at suitable intervals.

Route the hoses in such a way that they are not exposed to exhaust heat and other heating sources that may lead to the permissible temperature being exceeded.

Avoid damages from gravel, friction and contact with sharp edges.

Avoid excessive tension of the hoses.

Make sure that the smallest bending radius is not exceeded.

Make sure there is no leakage at the fittings; it will affect the accuracy of the measurement.

#### Basic installation:

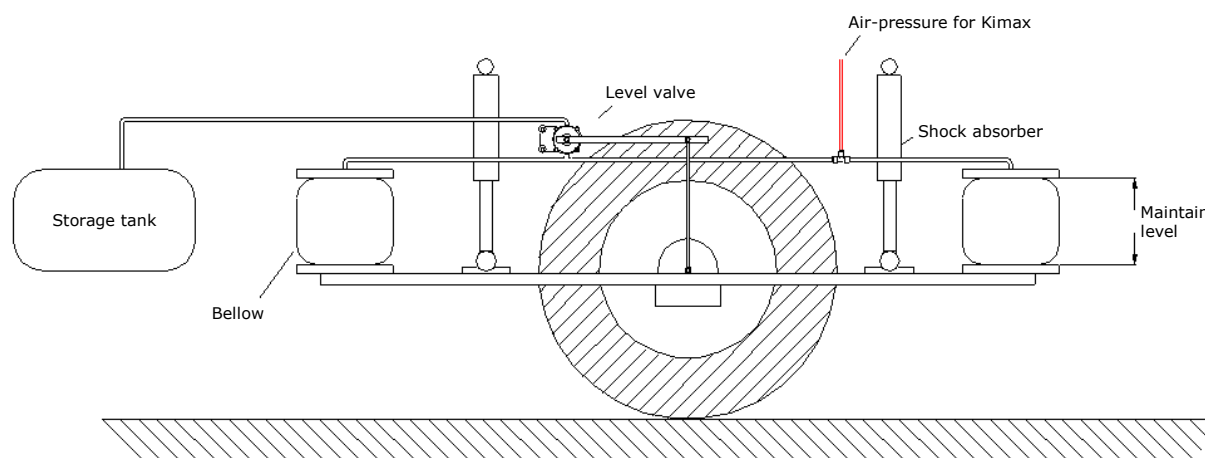

First of all, you have to identify the supply hoses for the bellows.

Depending on the layout of your vehicle you can have one or two bellows each side on each axle.

Your air suspension system can be deviated in a left-hand side and a right-hand side with individual air circuits and individual level controlling valves due to minimizing rolling.

In all cases, you will get the best accuracy and the fastest response, when you use Kimax 2 Instruments with double air-inlet for each axle.

In cases of steering axles or rear axles with common air circuit you can use a single input Kimax 2 instrument in order to save cost in installation and investment.



Cut the supply hose between the level valve and the bellow, assemble the hose again by using a T-piece.

Connect the instrument to the air bellows by means of an approved  $\text{Ø}6 \times 1$  mm polyurethane hose.

A throttle has to be put in every 6 mm hose at the T-piece end. It is important to mount the throttle in T-piece end of the hose, it will not work in the correct way, when you put it in the sensor end of the connecting hose.

The throttles protect the pressure sensors in the Kimax 2 instruments against burst-pressure. Furthermore, the throttles protect the air circuit against unexpected leakage if one of the 6 mm hoses suffers damage.

Unexpected loss of compressed air may affect your braking and steering capability.

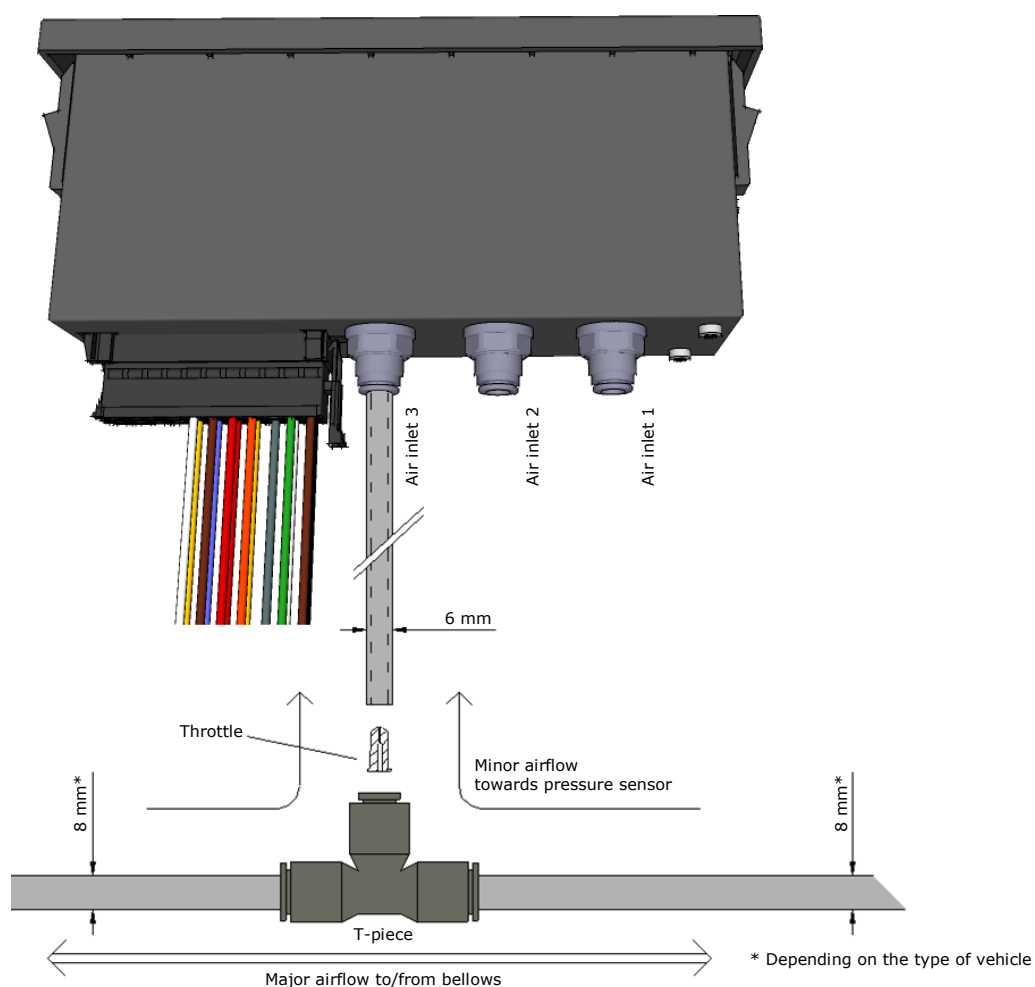

All air-inlets on Kimax instruments and all belonging fittings are quick-release type.

You need to make a clean cut in a right angle with a sharp knife before you connect a new tube to a Kimax instrument.

You can release the locking mechanism by push-in the releasing ring on the air-inlet. (A 7 mm open-ended spanner is a suitable tool for pushing-in the release ring meanwhile you slightly pull out the tube).

## Air-sensor installation on your vehicle

When the suspension system is deviated in a left hand side and in a right hand side by use of a level control valve in both left and right side, you can connect a Kimax instrument by using the standard fittings you get together with your instrument according to the below diagram.

### Basic layout

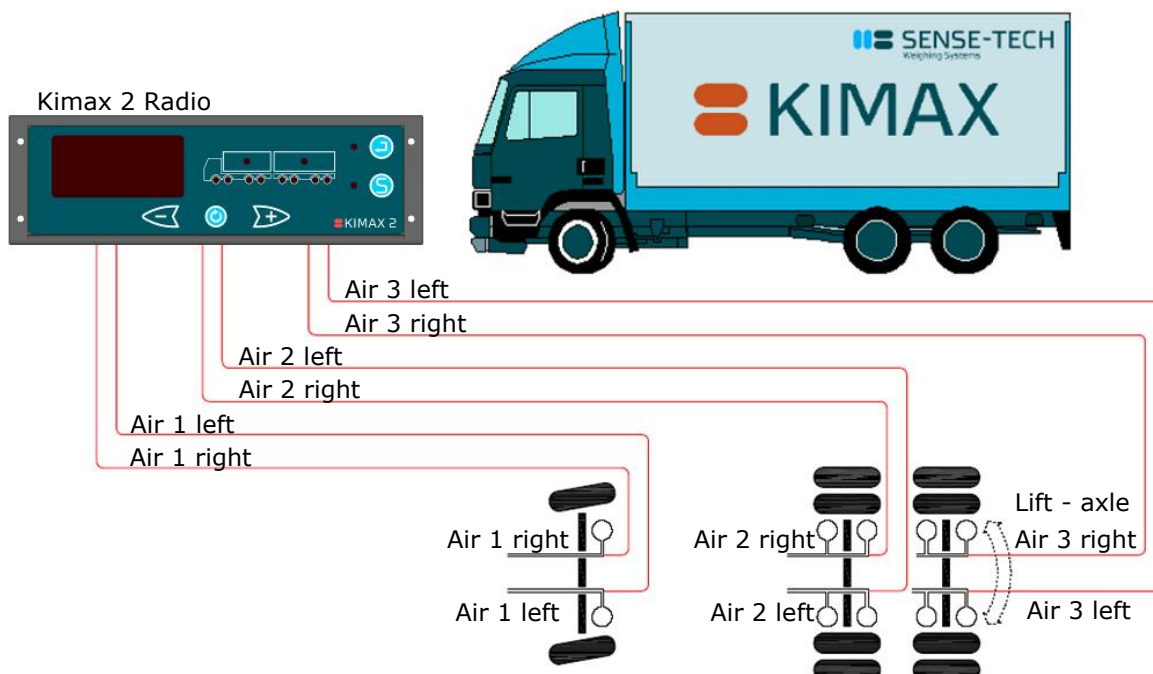

When your lift-axle is engaged, the pressure in air 3 left equals air 2 left and the pressure in air 3 right equals air 2 right, axle 2 and 3 share the weight of the rear of your vehicle.

When your lift-axle is disengaged (lifted from the road) the pressure in air 3 right and air 3 left is 0 bar and all the weight of the rear-end of your vehicle is carried and weighed by axle 2.

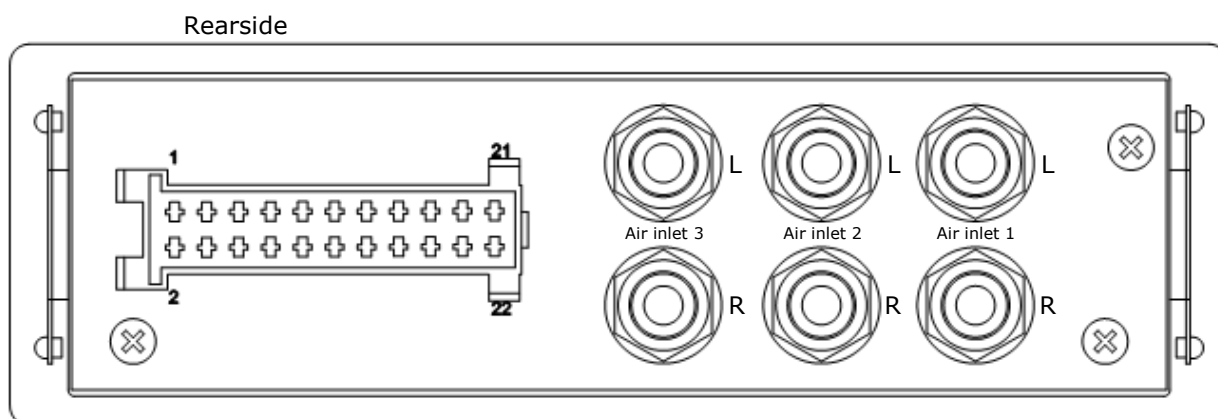

For additional layout options on different vehicle types please visit [www.kimax.com](http://www.kimax.com).

## SG-sensor installation (electrical installation)

### Connection diagram for a single SG sensor

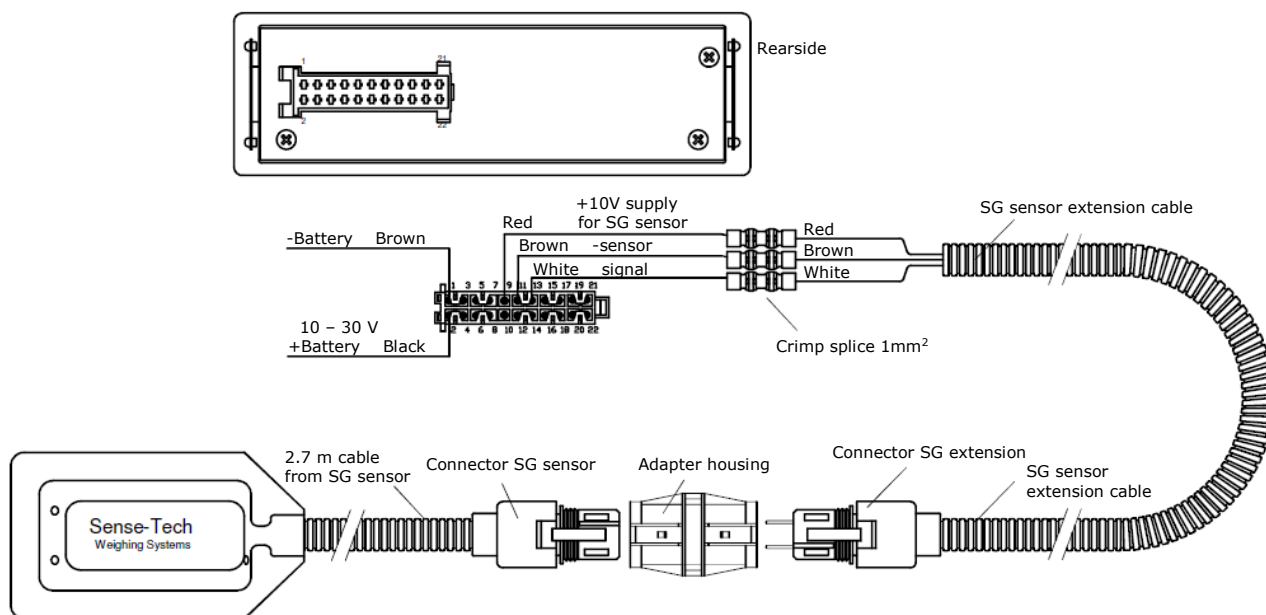

### Connection diagram for multiple SG sensors on individual axes

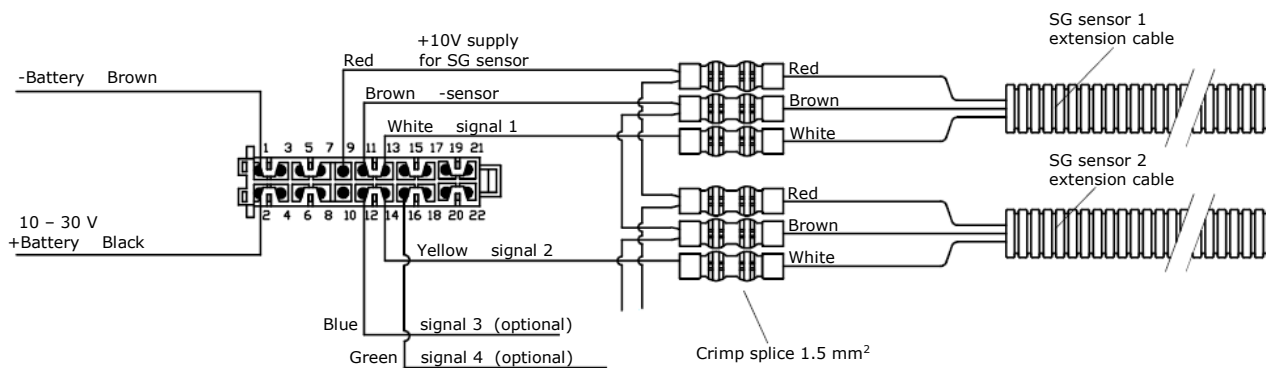

### Connection diagram for 1 SG sensor on front axle and 2 SG sensors on one rear axle

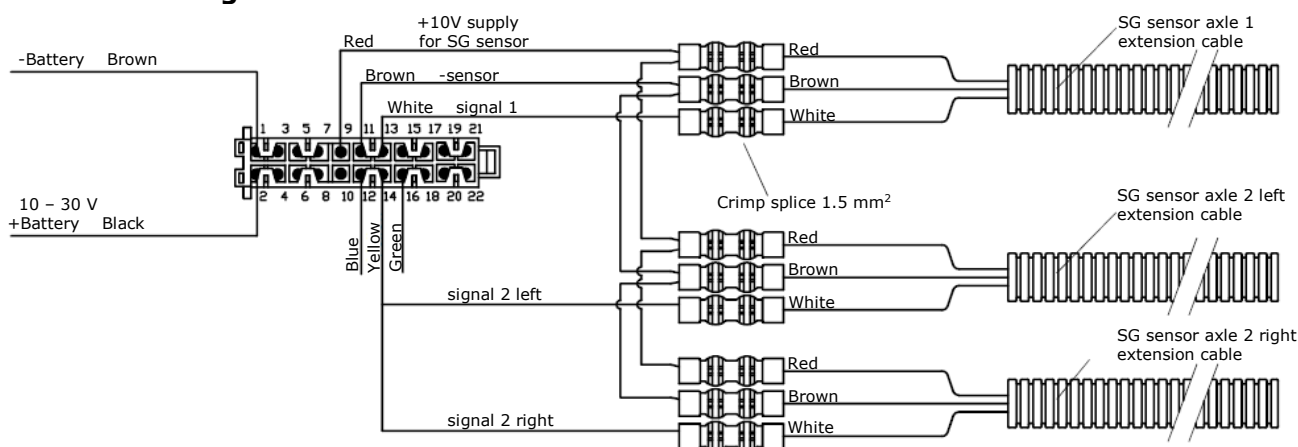

**Typical application:**

SG sensor on front axle combined with air suspension on rear axles.

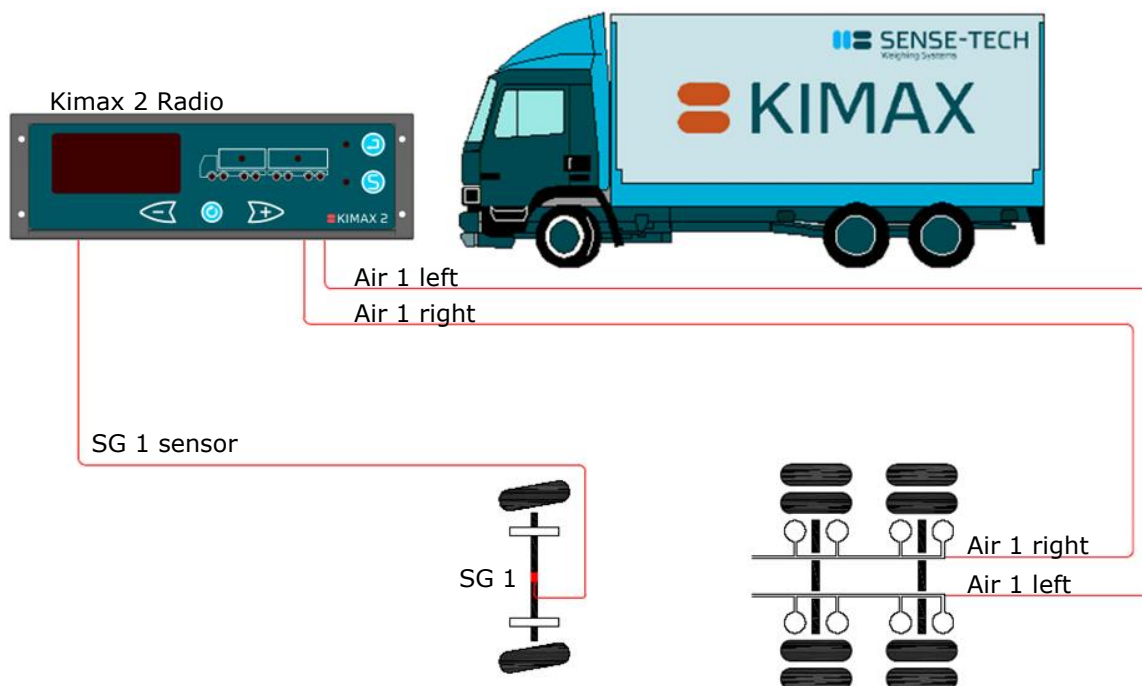

For information on how to install SG sensors on your vehicle please visit [www.kimax.com](http://www.kimax.com) where an installation procedure will be available for download.

## Frequently Asked Questions

- Q 1: Why is the configuration and calibration not done by the manufacturer?
- Q 2: What is HFA and why is it changeable?
- Q 3: Why do I have to configure CH?
- Q 4: Why do I have to calibrate both LO and HI?
- Q 5: Why do I have to calibrate each axle?
- Q 6: What are the OAA values?
- Q 7: What are the AdL and the AdH values?
- Q 8: Why are the axle LEDs flashing?
- Q 9: Why are my measured values very unstable?
- Q 10: Why is my Kimax 2 not responding, when I try to save new values?
- Q 11: How can I test my Kimax 2?
- A 1: *Kimax 2 instruments are pre-configured based on the information given to Sense-Tech Weighing Systems ApS, when the instrument was ordered. However the calibration cannot be done before the instrument is installed on the vehicle, since all vehicle types or brands are unique in their suspension. All instruments are however factory calibrated as a part of the in-house testing procedures.*
- A 2: *HFA is a setting that tells the instrument whether it is a Master or a Slave instrument and if it is installed on a truck or trailer. HFA is changeable, because a box can be mounted on either a truck or a trailer. A Master instrument must however be mounted on a truck and it has to be set to HFA = 0 or HFA = 1.*
- A 3: *CH is a setting that turns the input channels of the instruments on or off. Furthermore the axle LEDs are assigned to a specific input channel. For instance if the SG-sensor (or Air pressure sensor) connected to the first input channel (CH1) is measuring the load of the front axle, then the first axle LED (LED1) is assigned to the first input channel. Now it will be visualized that the first sensor is measuring the weight of the front axle.*
- A 4: *LO and HI needs to be calibrated specifically for your vehicle since this will teach the instrument to display the accurate weight at a given input from the sensors. The reason that there are two menus for this is purely mathematics. The axle load indicator functions by calculating a straight line and to do this it needs to get two set of coordinates existing of (x,y), and that is what you tell the instrument through LO and HI.*
- A 5: *Each axle (or axle group) needs to be calibrated since every axle is unique. Both weight and the air bellows in your suspension can vary among the other axles.*
- A 6: *The OAA values are sensor input values in percent (0.00-100%). This value tells you if the sensor is working properly, when the pressure is increasing the OAA value must also go up. If not, the sensor could be defect.*
- A 7: *The AdL and the AdH values are sensor input values in percent ranging from 0.00-99.9%. These values are the ones that the instrument is using when it calculates the axle pressure. The values emerges when you calibrate LO and HI.*
- A 8: *When the measured weight for a given input channel rises above the stored A1 alarm value for this input channel, the axle LED(s) associated with the channel starts to flash. The LEDs will stop flashing when the measured weight gets below the stored A1 alarm value or if a new A1 value (higher than the measured weight) is stored for the given input channel.*
- A 9: *The weight values can be very unstable as an effect of a faulty calibration. The most common mistake is that the LO values were **not** stored while the vehicle was **unloaded** and the HI values were **not** stored while the vehicle was **loaded**. Find out which channel behaves unusually. Try to compare the AdL and AdH values for that particular channel. They will probably almost be alike. Try to recalibrate the vehicle like described on page 21. It could also be a defect sensor. Look at the OAA value for the sensor. When the pressure on the sensor is increasing the OAA value must also go up*
- A 10: *If the Kimax instrument is locked, the display will show -L-, when trying to save values belonging to this instrument. The values will not be saved. To unlock the instrument follow the description given on page 25.*
- A 11: *The Kimax instrument can be tested like in the description given in the section Basic test setup on page 40.*

## Additional information

### How to build Kimax 2 Radio in:

Kimax 2 Radio is designed to fit directly into one of your free DIN radio slots. Your kit contains a mounting frame which can be placed in your free DIN radio slot when no frame is present already.

Connect the cable set to the electrical circuit on the vehicle and connect the Kimax 2 Radio to the cable set connector before you snap it in into the frame.

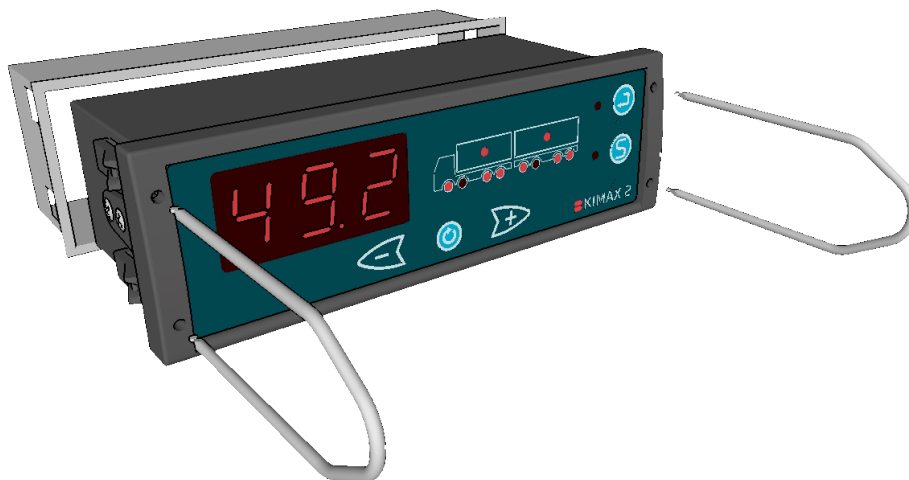

In order to replace the Kimax 2 Radio, you need to use the two belonging forks for releasing the snaps before you can pull the instrument out of the frame.

## Technical specification Kimax 2 Radio:

Supply voltage	10 ... 30 Volt direct current
Current consumption	max. 90 mA
Alarm 1	Flashing display
Alarm 2	Output open collector NPN max. 0.2 A/ 50 VDC
Display	Three-digits 7-segment LED, character height 20.3 mm
Measuring accuracy	±2 % of maximum load at 0 °C - +50 °C
Air connection	Quick release connection, 6 mm hose
Maximum pressure	15.5 bar (225 psi )
Operating pressure	range 0 to 10.5 bar (0 to 150 psi )
SG Sensor	0-20 mA input
Printer	RS-232 serial
On-Board Computer	RS-232 serial
Device bus	Power line communication
Operating temperature	-25 °C...+70 °C
Storage temperature	-40 °C...+70 °C
Dimensions(DIN format)	182 x 53 x 75 mm
Weight	approx. 550 g
Approval	CE and E1

### Examples of typically used sets:

#### Kimax 2 Radio 2 Air + 2 Air + 2 Air

Part number 032220-0131  
 1 x display unit, cabin  
 1 x mounting frame + connection cable  
 6 x angle fittings  
 6 x air pressure throttle dia. 6mm  
 6 x T-fittings dia. 8mm / 6mm / 8mm

#### Kimax 2 Radio 1 SG + 2 Air + 2 Air

Part number 033220-01D1  
 1 x display unit, cabin  
 1 x mounting frame + connection cable  
 4 x angle fittings  
 4 x air pressure throttle dia. 6mm  
 4 x T-fittings dia. 8mm / 6mm / 8mm

#### Kimax 2 Radio 1 SG + 2 SG

Part number 033400-01E0  
 1 x display unit, cabin  
 1 x mounting frame + connection cable

The policy of Sense-Tech Weighing Systems ApS is to continually improve our products. This means that product specifications may change without prior notice.

Find additional technical information on [www.kimax.com](http://www.kimax.com).

## Tools and parts you may need for proper installation:

Gluing Set	STWS part no 10139
T-piece 8 - 6 - 8 mm	STWS part no 43002
T-piece 9 - 6 - 9 mm	STWS part no 43019
T-piece 3/8" - 6 mm - 3/8"	STWS part no 43020
Angle fitting 6 mm	STWS part no 43001
4 mm throttles for 6 mm Polyurethane (PU) or Polyamid (PA) hose	STWS part no 43004
6 mm Polyurethane (PU) or Polyamide (PA) hose	
10 bar manometer with 6 mm tubing	
Manual air pump	
Hose cutting knife	
Cable strips	

## Basic test setup

To test two instruments with air pressure sensors (e.g. 031110-01 and 051110-010) you can connect them as shown here:

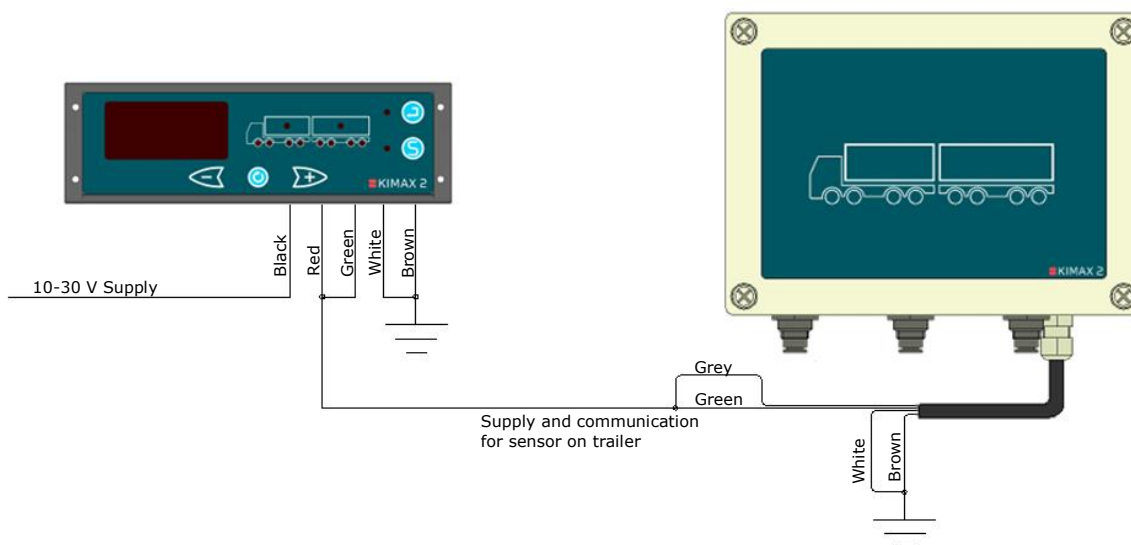

The instruments are configured as follows:

Kimax 2 Radio: HFA = 1, CH1 = LED1, CH2 = LED3 and CH3 = LED4.

Kimax 2 Sensor: HFA = 3, CH5 = LED5, CH6 = LED7 and CH7 = LED8.

All channels are LO-calibrated to 0,00 t when no pressure is applied to all the channels and HI-calibrated to 10,0 t when 10 bar is applied to all the channels. Apply e.g. 6 bar to all channels and you will get a total reading of 6 times 6,00 equal 36,0 on the display of the Kimax 2 Radio.

If you disconnect the white wire from ground, the communication between the two instruments will stop and the reading on the Radio panel will be 3 times 6,00 equal 18,0. Connect the white wire again and the reading will be 36,0 again. If the reading is not as expected, you may have to recalibrate the instruments. See page 21.

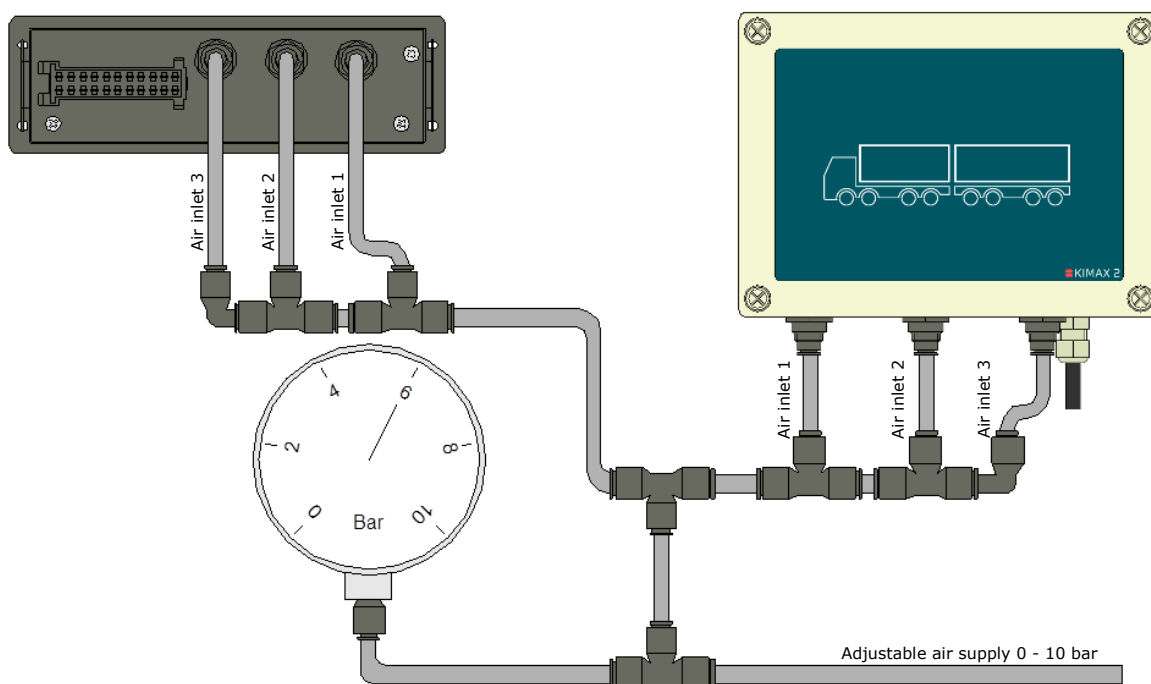

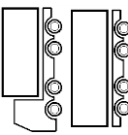
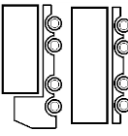
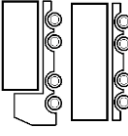
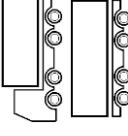
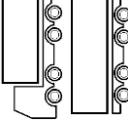
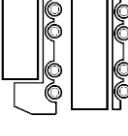
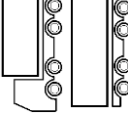
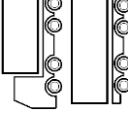

## Calibration Scheme

	Channel #1	Channel #2	Channel #3	Channel #4	Channel #5	Channel #6	Channel #7	Channel #8
<b>OAA empty</b> 0.00.-99.9 %								
<b>OAA full</b> 0.00.-99.9 %								
<b>LO</b> 0.00.-99.9 Ton								
<b>HI</b> 0.00.-99.9 Ton								
<b>AdL</b> 0.00.-99.9 %								
<b>AdH</b> 0.00.-99.9 %								
<b>A1</b> 0.00.-99.9 Ton								
<b>CH</b>								

HFA (Trailer):

Date:

Calibrated by:

HFA (Truck):

Car ident no:

## Notes



